

Ortek, Минск +375447584780 viber email minsk17@tut.by

каталог, описание, технические, характеристики, datasheet, параметры, маркировка, габариты, фото, модуль, **Ortek**, даташит, Твёрдотельное реле, трехфазное, однофазное, датчик

КАТАЛОГ 2025г.

Ortek в Беларуси

купить, продажа в **Минске, Беларусь**

электронные компоненты

[где и как купить в Минске?](#)



Продукция Ortek

Категории: Энкодеры, Инклинометры, Управление и позиционирование, Тахометры, Счетчики, Обнаружение, движения и присутствия, Датчики измерения расстояния, Ограничитель, скорости, Тахогенераторы, Камеры, машинного, зрения, **ortek**

Product Information



Control 4000 Photometric Analyzers

Control 8000 Universal Analyzers



- english
- deutsch
- español
- portuguese
- русский язык
- 中文
- 日本語
- français
- italiano

For over 30 years, optek has focused on measuring process liquids through their interaction with light in facilities all over the world. Although global, optek remains a family owned company with a team of more than 100 qualified, customer-driven professionals.

Our confidence is born from experience. With the expertise of more than 30,000 installations worldwide, our value to the customer resides in providing a superior product that pays back. High quality materials withstand the toughest process conditions including aggressive media, high temperature, and

high pressure applications. Cleanability is ensured using high quality wetted materials, superior design, as well as sapphire optical windows.

As a global partner to various industries, optek offers the most advanced technologies including superior signal amplification, inline calibration support, PROFIBUS® PA, FOUNDATION™ Fieldbus and multilingual user interfaces for easy onsite operations.

Our support ensures long term satisfaction with programs such as “Speed-Parts” and “SwapRepair” to provide our

customers sustainable operations and minimized downtime at the lowest cost of ownership.

Conformity to international (ISO 9001), industry-specific (FM/ATEX approval) or company standards is easily achieved with optek. Wherever process composition is controlled, the name optek has become synonymous with world-class products and support.

**Optimize your process
with optek inline control.**



Content

C4000 / C8000 – converters	03
C4000 – photometric converter (configurations)	04
C8000 – universal converter (configurations)	06
C4000 / C8000 – accessories	08
C4000 / C8000 – technical data	09
Optical sensors – overview	10
Optical sensors – principles	11
Turbidity sensors AF16-N / TF16-N	12
Color sensors AF16-F / AF26	14
UV sensors AF45 / AF46	16
Probe sensors AS16 / AS56	18
Probe sensors ASD12-N / ASD25-N	20
Conductivity sensor ACF60 / ACS60	22
pH electrode adapter PF12	23
Single Use Cell (S.U.C.)	24
Sensor body (armature)	26
System – calibration	27
optek – worldwide contact	28

See our TOP 5 brochures for applications in your industry.



Control 4000 and Control 8000 are powerful, microprocessor-based converters.

The advanced modular design enables precision process monitoring and control with multiple sensors.

The menu-based software is easy to use and configure, and available in German, English, French, Dutch, Spanish, Russian and Portuguese. The software includes adjustable signal damping, 16 linearization tables and advanced calculation capabilities. Multiple outputs transmit the measurements in real-time for precise process control. An integrated data logger captures vital process information for quality assurance and plant control records.

This data is easily transferred to a PC via an RS232 port.

C4000 - Photometric Converter

The Control 4000 photometric converter is designed for optek ultraviolet (UV), visible (VIS), near-infrared (NIR) absorption based and scattered light based sensors.

The graphic display can show absorbance, transmittance and concentration in real-time and in any unit of measure such as CU, OD, %Tr., ppm (DE), EBC, FTU, g/L and many others.

These measurements may also be displayed as text, bar graphs or trend values. A factory zero is implemented as an additional feature for scattered light sensors. A secondary user zero for additional offset is included, as well as a slope and shift adjustment. This manual adjustment can be used to compensate for long-term process related disturbances.

C8000 - Universal Converter

The Control 8000 universal converter operates optek photometric sensors along with 2 pH-probes and 2 conductivity sensors (optek patented ACF series) simultaneously.

All measurements (2 x optical, 2 x pH, 2 x conductivity and 2 x temperature) are transmitted with the standard 8 mA-outputs and may also be displayed as text and bar graphs.

The combination of C8000 and ACF60 conductivity sensors allows a wide dynamic range from 0 – 10 μ S/cm up to 0 – 850 mS/cm with the same sensor.

Sensors	C4000	C8000
Optical sensors (optek)	1 - 4	1 - 2
pH-Probes	—	2
Conductivity sensors (optek)	—	2
Communications	C4000	C8000
mA-outputs (0/4 - 20 mA)	2 / 4	8
mA-inputs (4 - 20 mA)	0 / 2	—
Relay-outputs	3	—
Failsafe-relay (active)	✓	✓
Remote-IN: Zero	✓	✓
Remote-IN: Range	✓	✓
Remote-IN: Hold	✓	—
Profibus® PA	✓	—
FOUNDATION™ Fieldbus	✓	✓
Explosion-Proof	C4000	C8000
Ex-proof ATEX	✓	—
Ex-proof FM	✓	—

04 | C4000 - Photometric Converter



The Control 4000 is available in various configurations to meet the exact needs of your process.

- Multiple photometric sensors
- Multiple parameter sets
- Multiple linearization tables
- Data logger
- Factory zero for scattered light sensors
- Remote control
- Ex proof versions FM and ATEX

Sensor				4101	4201	4202	—
1	2	3	4	4121	4221	4222	4422
				4151	4251	4252	4452
				4161	4261	4262	4462
AF16 (AS16)	—	—	—	✓	✓	✓	✓
AF16 (AS16)	AF16 (AS16)	—	—	—	—	✓	✓
AF16 (AS16)	AF26 or AF45 or TF16	—	—	—	—	—	✓
AF26	—	—	—	—	✓	✓	✓
AF26	AF26 or AF45 or TF16	—	—	—	—	—	✓
AF45	—	—	—	—	✓	✓	✓
AF45	AF45 or TF16	—	—	—	—	—	✓
AF46	—	—	—	—	—	—	✓
TF16	—	—	—	—	✓	✓	✓
TF16	TF16	—	—	—	—	—	✓
ASD12 or ASD25	—	—	—	✓	✓	✓	✓
ASD12 or ASD25	ASD12 or ASD25	—	—	—	✓	✓	✓
ASD12 or ASD25	ASD12 or ASD25	ASD12 or ASD25	—	—	—	—	✓
ASD12 or ASD25	ASD12 or ASD25	ASD12 or ASD25	ASD12 or ASD25	—	—	—	✓

*C4422 can handle up to 4 sensors AS56

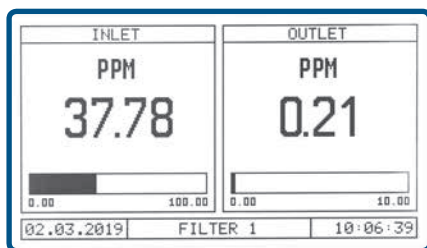

Display Modes

- 1 - 4 simultaneously displayed values (configurable)
- Numeric with bar graph and alarm setting
- Trendline

Remote Control

- Parameter set (e.g. range)
- Zero
- Hold

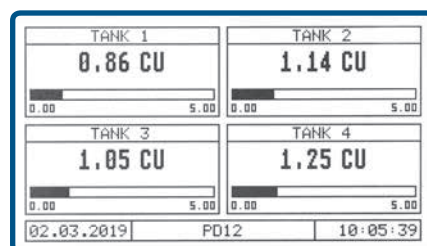

Software Tools

- 8 parameter sets (incl. range, alarm, display, etc.)
- 16 linearization tables (max. 11 points)
- 8 offset and slope sets
- Auto zero (local or remotely activated)
- Factory zero (scattered light sensors only)
- Password protection (3 levels and none)
- Memory (non-volatile) retains all configurations and logged data

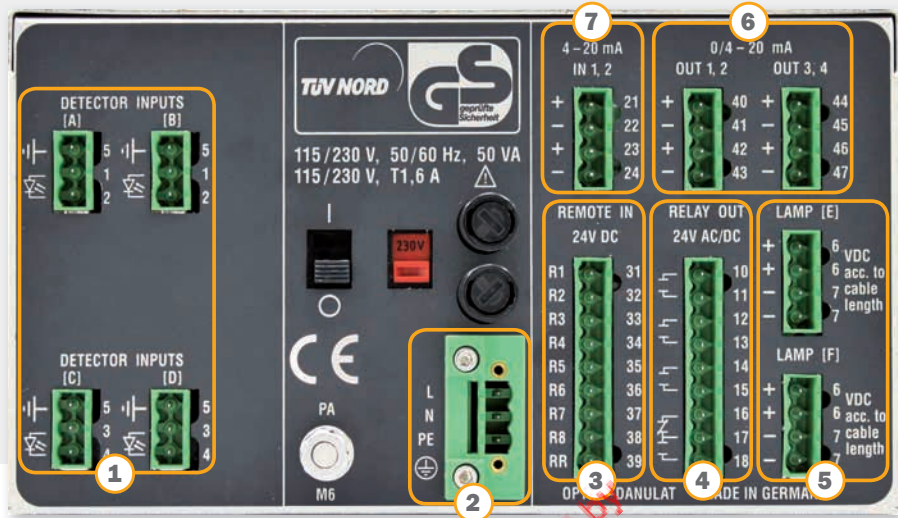
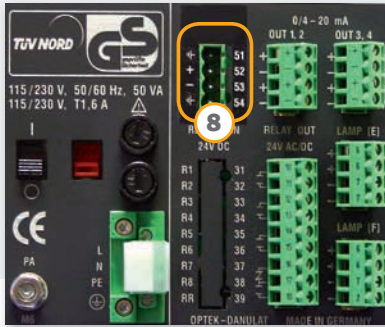

C4000 Configuration		4101	4201	4202	4121		4221	4222		4422		
Profibus® PA	8					4151	4251		4252		4452	
FOUNDATION™ Fieldbus						4161	4261		4262		4462	
Detector inputs (optek)	1	1	2	2	1	1	2	2	2	2	4	4
Power supply 115/230 or 24 V	2	✓	✓	✓	✓	✓	✓	✓	✓	✓	✓	✓
Remote-IN: (Zero, Range, Hold)	3	—	—	—	✓	—	✓	—	✓	—	✓	—
Relay-outputs	4	3	3	3	3	3	3	3	3	3	3	3
Failsafe-relay (active)		✓	✓	✓	✓	✓	✓	✓	✓	✓	✓	✓
Lamp outputs (optek)	5	1	1	2	1	1	1	1	2	2	2	2
mA-outputs (0/4 - 20 mA)	6	2	2	4	2	2	2	2	4	4	4	4
mA-inputs (4 -20 mA)	7	—	—	—	2	—	2	—	2	—	2	—
pH-probe		— (with C8000 only)										
Conductivity (optek ACF)		— (with C8000 only)										
Ex-proof (optional)		✓	✓	✓	✓	✓	✓	✓	✓	✓	✓	✓



PROFIBUS® PA

- Fulfills application profile for process automation (version 3.01)
- Cyclic:
 - 4 measuring outputs, each with 4x limit and status
 - Status of all 4 relays
 - 2 measuring inputs
- Acyclic:
 - Zero, Hold, Product change, Monitors, Error codes
- GSD, EDD file and DTM for FDT interface provided
- Interface to profibus DP segment using a segment coupler

FOUNDATION™ Fieldbus

- Fulfills FOUNDATION™ Fieldbus H1 (IEC 61158-2)
- Registered function blocks: 1xRB, 8xAI(s), 4xDI(s), 2xAO(s)
- H1 Profile class: 31P, 32L
- H1 Device class: basic, link master
- 4 Measuring outputs with status (C8000 8 measuring outputs with status)
- 4 Relays with status (C8000 1 Relay with status)
- 2 Measuring inputs (only C4000)
- With optek specific resource block parameter: Zero, Hold, Product change
- Device description (DD) and capabilities files provided

06 | C8000 - Universal Converter



C8000 Sensor Combination		
1 AF, AS or TF Sensor or 2 ASD Sensors		
AF16	VIS-NIR Absorption	1
AS16	VIS-NIR Absorption	1
AF26	Dual Channel Color	1
AF45	UV-Absorption	1
AF46	Dual Channel UV	1
TF16	11° Scattered Light	1
ASD12	NIR Absorption	2
ASD25	NIR Absorption	2
4 Electrochemical Sensors		
pH-probe		2
Conductivity optek ACF (6-pol)		2

The Control 8000 is available in various configurations to meet the exact needs of your process.

- 1 or 2 photometric sensors
- 2 conductivity sensors
- 2 pH sensors
- Multiple parameter sets
- Multiple linearization tables
- Data logger
- Factory zero for scattered light sensors
- Remote control

Software Tools

- 8 parameter sets (incl. range, display etc.)
- 16 linearization tables (max. 11 points)
- 8 offset and slope sets
- Auto zero (local or remotely activated)
- Factory zero (scattered light sensors only)
- Password protection (3 levels and none)
- Memory (non-volatile) retains all configurations and logged data

Remote Control

- Parameter set
- Zero

Display Modes

- 2 - 8 simultaneously displayed values (configurable)
- Numeric with bar graph

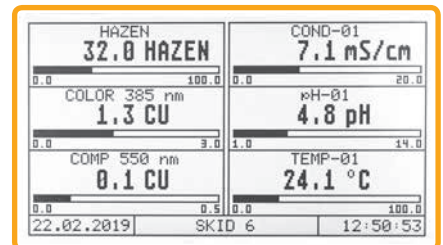
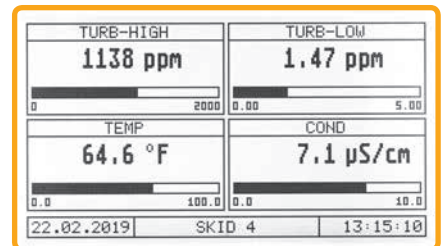
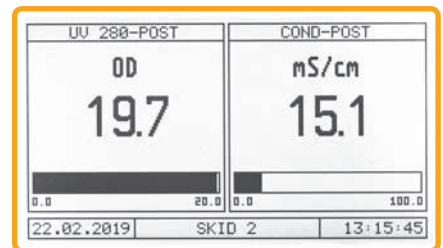

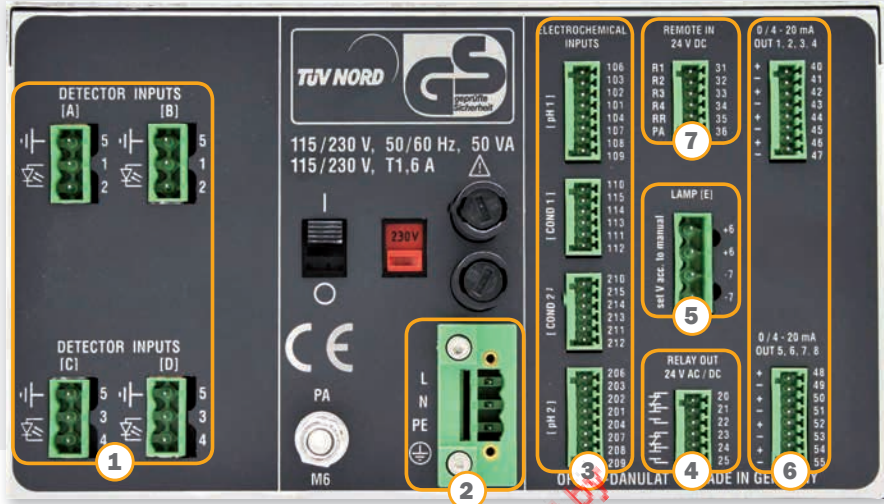
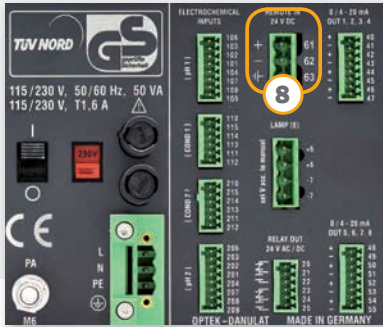

8 Measurements 5 Sensors 3 Armatures 1 Converter

The C8000 provides optical density or forward scatter turbidity measurements in the ultraviolet (UV), visible (VIS), and near infrared (NIR) ranges. In addition to optical sensors, the C8000 monitors up to two pH sensors and two conductivity sensors with integrated temperature measurements. One converter assures easy operation with an intuitive user interface in a compact package.

C8000 - Configuration	C8480	C8486	C8080	C8086
Detector inputs (optek)	①	4	4	—
Power supply 115/230 or 24 V	②	✓	✓	✓
Remote-IN: (Zero, Range)	⑦	✓	—	✓
Relay-outputs		—	—	—
Failsafe-relay (active)	④	✓	✓	✓
Lamp output (optek)	⑤	✓	✓	—
mA-outputs (0/4 - 20 mA)	⑥	8	8	8
mA-inputs (4 -20 mA)		(with C4000 only)		
Profibus® PA		(with C4000 only)		
FOUNDATION™ Fieldbus	⑧	—	✓	—
pH-probe	③	2	2	2
Conductivity (optek ACF)		2	2	2
Ex-proof (optional)		(with C4000 only)		

Application (example): Pre- and post-column chromatography monitoring

During purification, accurate, reliable and repeatable measurements are necessary to ensure accurate pooling to maximize yields and protein/DNA fraction purity.

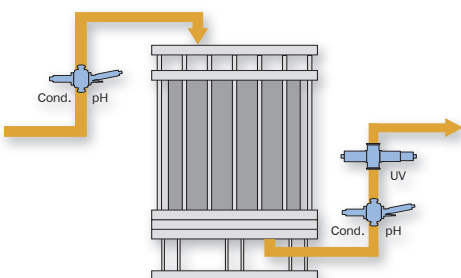

1 Converter	3 Armatures	5 Sensors	8 Measurements
C8480	Line size: 0.50 in. Clamp TC L14 AM7 PN: 0120-3507-33 OPL: 5 mm Volume: < 22 ml Height: 96 mm (3.78 in.)	AF46 Dual Channel UV Absorption	UV Absorption at 280 nm
			UV Absorption at 300 nm
	Line size: 0.50 in. Clamp TC L14 AM7 PN: 0120-3508-33 Volume: < 44 ml Height: 96 mm (3.78 in.)	ACF60 (patented 6 electrode probe based on 4 pole technique)	Conductivity 0 - 10 µS/cm to 0 - 850 mS/cm
			Temperature -10 °C - 135 °C (14 - 275 °F)
	Line size: 0.50 in. Clamp TC L14 AM7 PN: 0120-3508-33 Volume: < 44 ml Height: 96 mm (3.78 in.)	PF12 (various pH electrodes)	pH 0 - 14 pH
			Conductivity 0 - 10 µS/cm to 0 - 850 mS/cm
		Temperature -10 °C - 135 °C (14 - 275 °F)	
		pH 0 - 14 pH	

08 | C4000/C8000 - Accessories

The PC-Transfer software allows communication between converter and PC via a RS-232 port. Documentation and set-up including identical set-up of multiple converters are made simple.

The advanced version features an additional mathematics module for complex measuring tasks and parameter creation on the PC.

- Converter to PC:**
- Parameter set
 - Trend data online
 - Data logger
- PC to converter:**
- Parameter set
 - Software update
 - Mathematics module (C4000 only)



S19-42
 Wall mount housing (IP65)
 Material: stainless steel 1.4301 / SS304
 A: 301 mm (11.9 in.)
 B: 340 mm (13.4 in.)
 C: 237 mm (9.4 in.)

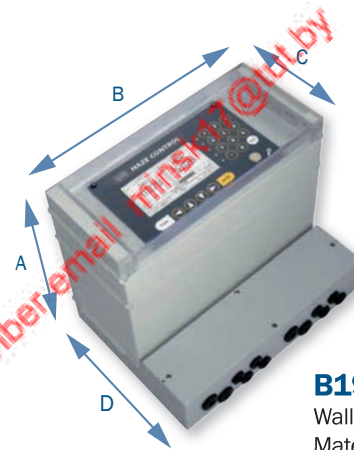

B19-42
 Wall mount housing (IP66)
 Material: plastic (ABS)
 A: 287 mm (11.3 in.)
 B: 353 mm (13.9 in.)
 C: 147 mm (5.8 in.)
 D: 237 mm (9.4 in.)



T19-42
 Table top housing
 Material: aluminum
 A: 150 mm (5.9 in.)
 B: 260 mm (10.2 in.)
 C: 320 mm (12.6 in.)

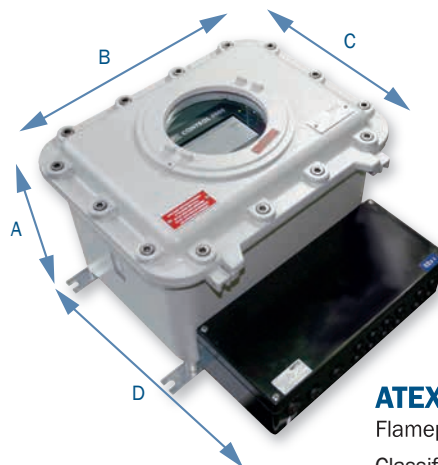

ATEX EX d
 Flameproof housing EX d (IP65)
 Classification:
 III 2(2) G Ex de [ia Gb] IIB+ H2 T5 Gb
 Approval:
 KEMA 08 ATEX 0123
 Material: cast aluminum
 A: 320 mm (12.6 in.)
 B: 450 mm (17.7 in.)
 C: 355 mm (14.0 in.)
 D: 500 mm (19.7 in.)

Front-Kit
 Front panel mounting (IP65 - front only)
 (not shown)

Technical Data	C4000	C8000
Housing	19"- version for mounting in control cabinets 3 U / 42 HP - dimensions: W 213.0 mm (8.39 in.) H 128.4 mm (5.06 in.) D 230.0 mm (9.05 in.) - material: stainless steel / polyester / silicone / glass / diverse plastics - protection: front IP40 / rear IP20 (mains supply secured against accidental touching)	
Display	LCD graphic display black on white (240 x 128 pixel), LED background illuminated	
Operation	18-button keyboard	
System clock	accuracy approx. 1 minute/month (battery life approx. 15 years)	
LED	1 LED (green): power on 1 LED (red-flashing): system failure 3 LEDs (yellow): alarm I, II, III	1 LED (green): power on 1 LED (red-flashing): system failure
Data logger	4 parallel measuring values (ring buffer with approx. 25,000 data points x 4) (interval: 1/second - 1/hour)	8 parallel measuring values (ring buffer with approx. 12,500 data points x 8) (interval: 1/second - 1/hour)
Sensor-inputs	1 - 4 for optek photometric sensors n/a n/a	4 for optek photometric sensors 2 for optek conductivity sensors 2 for pH-probes (temperature compensated)
Sensor-inputs (explosion proof)	optional: 1 - 4 for optek photometric sensors (intrinsic safe)	n/a
mA-inputs	optional: 2 x 4 - 20 mA (functionally galvanically isolated) - accuracy: < 0.5 % - resolution: < 0.05 % - load: < 200 Ohm	n/a
Remote-inputs	optional: 7 x 24 V (19 ... 29 V DC), typically 6.0 mA for remote range setting, remote zero, remote hold	standard: 4 x 24 V (19 - 29 V DC), typically 6.0 mA for remote range setting, remote zero
Profibus® PA interface	optional: Profibus® PA profile, version 3.01, amendment 2	n/a
FOUNDATION™ Fieldbus interface	optional: FOUNDATION™ Fieldbus H1 (IEC 61158-2)	
Sensor lamp-outputs	1 or 2 lamp supply for optek photometric sensors 4.5 ... 8.5 V DC	1 lamp supply for optek photometric sensors 4.5 ... 7.8 V DC
mA-outputs	2 or 4 x 0/4 - 20 mA (NAMUR) (functionally galvanically isolated) - accuracy: < 0.5 % - resolution: < 0.05 % - load: < 600 Ohm	8 x 0/4 - 20 mA (NAMUR) (functionally galvanically isolated) - accuracy: < 0.5 % - resolution: < 0.05 % - load: < 600 Ohm
Relay-outputs	3 independent software-configurable relay contacts 0 - 50 V AC, 0 - 75 V DC, 0 - 2 A - for alarm or status feedback - initiation delay configurable: 0 - 999 sec.	n/a
Failsafe-output	1 SPDT contact to alarm in case of lamp or system failure (active) 0 - 50 V AC, 0 - 75 V DC, 0 - 2 A	
Serial communication	RS232 bi-directional interface on front panel (with software package optek PC-transfer) - upload / download of configuration, download of data logger content	
Cable lengths (sensor)	2, 3, 5, 10, 15, 20, 30 ... 100 m (7, 10, 16, 33, 49, 66, 98 ... 328 ft) cable length > 100 m on request up to 1,000 m (3,280 ft) sensors AS56 / AS16: max: 50 m sensors ASD: 2, 3, 5 or 10 m (7, 10, 16 or 33 ft.)	2, 3, 5, 10, 15, 20, 30 m (7, 10, 16, 33, 49, 66, 98 ft) sensors ASD: 2, 3, 5 or 10 m (7, 10, 16 or 33 ft.)
Power supply	115 / 230 V AC, selectable (93.5 - 132 / 187 - 264 V AC, 47 - 64 Hz) or 24 V AC / DC (AC: 20.4 - 26.4 V AC, 47 - 64 Hz; DC: 20.4 - 28.8 V DC) - power consumption: < 50 VA	
Ambient conditions	temperature during operation (no direct sunlight): - converter: -10 - 55 °C (14 - 131 °F) - with optional stainless steel housing S19-42 (IP65): -20 - 45 °C (-4 - 113 °F) - with optional plastic housing B19-42 (IP66): -10 - 40 °C (14 - 104 °F) (C4000 only) - with optional EX d housing (IP65): -20 - 40 °C (-4 - 104 °F) (C4000 only) temperature during transport (no direct sunlight) : -20 - 70 °C (-4 - 158 °F)	
Software languages	English, German, French, Spanish, Dutch, Portuguese, Russian	

10 | Optical Sensors Overview

Sensor Specifications								
	ASD	AS16	AS56	AF16	AF26	AF45	AF46	TF16
Basic Measuring Principle:	①	②	②	③	④	⑤	⑥	⑦
Absorption of light - 1-channel	✓	✓	✓	✓	✓	✓	✓	✓
Absorption of light - 2-channel	—	—	—	—	✓	—	✓	—
Scattering of light - 11°	—	—	—	—	—	—	—	✓
Basic Measuring Ranges:								
CU / AU / OD / %-Tr.	✓	✓	✓	✓	✓	✓	✓	✓
ppm / FTU / EBC	—	—	—	—	—	—	—	✓
Wavelengths Used:								
NIR (840 - 910 nm)	✓	—	—	—	—	—	—	—
NIR (730 - 970 nm) - Turbidity	—	AS16-N	AS56-N	AF16-N	—	—	—	✓
VIS (385 - 1000 nm) - Color	—	—	—	AF16-F	—	—	—	—
VIS (430 - 620 nm) - Color	—	AS16-F	AS56-F	AF16-F	—	—	—	—
UV (254 - 313 nm)	—	—	—	—	—	✓	✓	—
Windows and OPL:								
Window material: Pyrex®	—	—	—	—	✓	—	—	✓
Window material: Sapphire	✓	✓	✓	✓	✓	✓	✓	✓
OPL (optical path length) mm	(*)	1 - 40	5 / 10	1 - 1000	1 - 1000	1 - 160	1 - 160	40
Window gaskets (various)	n/a	n/a	n/a	✓	✓	✓	✓	✓
Process Adaption:								
Armature in pipe	—	—	—	✓	✓	✓	✓	✓
Insertion through port	✓	—	✓	—	—	—	—	—
Process Ratings:								
Max. pressure up to bar (psi)	(*)	20 (290)	10 (145)	100 (1450) depending on materials and design (higher on request)				
Max. temperature up to °C (°F) - continuously	(*)	100 (212)	90 (194)	120 (248)	120 (248)	70 (158)	70 (158)	120 (248)
Options:								
HT (high temperature) up to °C (°F) - continuously	—	—	—	240 (464)	240 (464)	120 (248)	120 (248)	240 (464)
VB (calibration adapter)	—	✓	—	✓	✓	✓	✓	—
EX-proof ATEX	—	—	—	✓	✓	✓	✓	✓
EX-proof FM	—	—	—	✓	✓	✓	✓	✓

* See individual sensor data for details

Pressure and temperature ratings specified herein may be subject to limitations - see instruction manual.
The appropriate choice of material for all wetted parts is the sole responsibility of the user. Data given are subject to changes without prior notice.

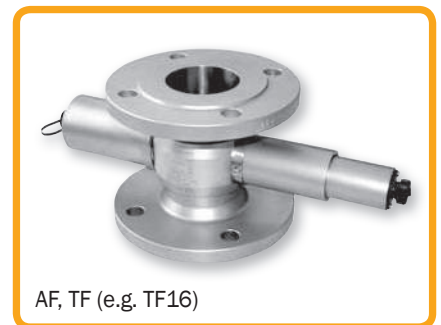

1 Probe ASD12 / ASD25

NIR-Absorption,
single channel concentration measurement

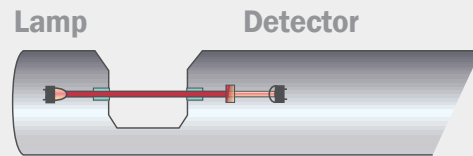

2 Probe AS16 / AS56

VIS- and NIR-Absorption,
single channel concentration and
color measurement

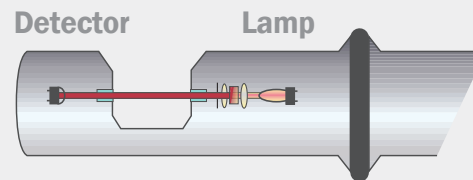

3 Sensor AF16

VIS- and NIR-Absorption,
single channel concentration
and color measurement

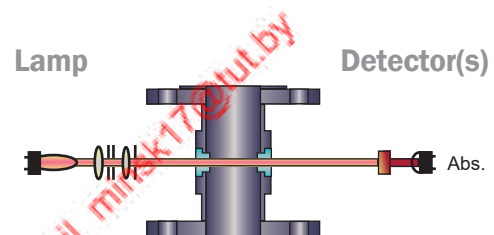

4 Sensor AF26

VIS-Absorption,
dual channel color measurement
with turbidity compensation

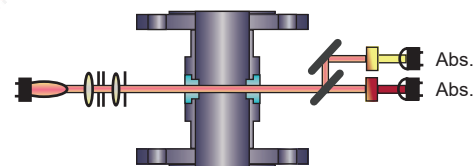

5 Sensor AF45

UV-Absorption,
single channel concentration measurement
with compensation of lamp intensity

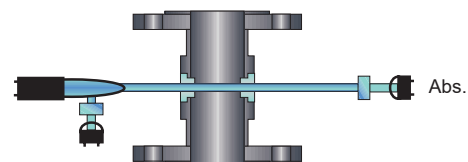

6 Sensor AF46

UV-Absorption,
dual channel concentration measurement
with compensation of lamp intensity

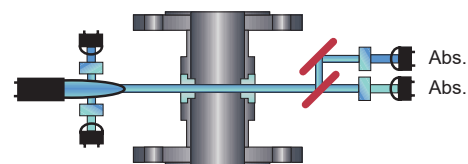

7 Sensor TF16

11° scattered light and NIR-Absorption
dual channel turbidity measurement

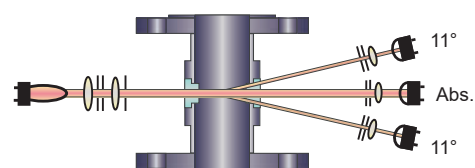

12 | Turbidity Sensors AF16-N/TF16-N

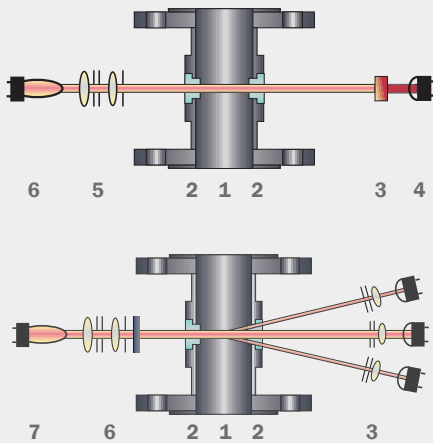

3 Model AF16-N Single Channel Absorption (NIR)

- | | |
|-----------------|------------------------|
| 1 Sensor body | 2 Windows |
| 3 Filter | 4 Measurement detector |
| 5 Optics module | 6 Lamp module |

7 Model TF16-N Dual Channel Scattered Light (11°)

- | | |
|-----------------------|----------------------|
| 1 Sensor body | 2 Windows |
| 3 Focusing optics | 4 Detector 0° (Abs.) |
| 5 Eight 11° detectors | 6 Optics module |
| 7 Lamp module | |

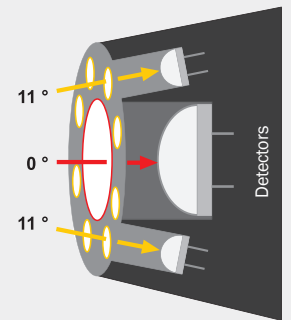

Models AF16-N and TF16-N are high precision turbidity sensors for use in various industries. The sensors are designed for inline operation and provide accurate concentration measurements with remarkable repeatability, linearity and resolution.

Modular construction of the sensors offers maximum flexibility in adapting to various process needs. Options include electro-polished sensor bodies, hazardous location (explosion-proof) capability, chemical resistant materials (sapphire windows, titanium, Hastelloy, etc.) and high temperature or high pressure versions.

AF16-N (NIR-Absorption / Turbidity)

A special tungsten lamp produces a constant light beam that passes through the process medium. The attenuation of the light intensity, caused by absorption and/or scattering by dissolved and undissolved substances, is detected by a sealed silicon photodiode.

The AF16-N uses light from 730 - 970 nm (NIR) to measure solids concentration independent from color or color changes. Depending on the optical path length, measuring ranges from high percentage (OPL = 1 mm) to 0 - 100 ppm (OPL = 160 mm) are possible.

TF16-N (Scattered Light / Turbidity)

Light scattered from particles (trace suspended solids, undissolved liquids or gas bubbles) in the medium is detected by eight hermetically sealed silicon photodiodes at an angle of 11°. At the same time, the unscattered light is detected by a reference photodiode (comparable to an AF16-N). The sensor can be calibrated in ppm (DE), EBC or FTU and measures extremely low particle sizes and concentrations. Additionally, high particle concentrations can be monitored independent of color at the direct light detector.

OPL

Special optical windows are made from a single crystal sapphire, providing superior resistance to all abrasive and corrosive media. With the appropriate choice of sensor bodies and windows in various lengths, the optimal OPL

(optical path length = distance between the windows) can be achieved to meet the measurement requirements, i.e., low/high measuring ranges at highest resolution.

Typical Applications:

- Separator control, pulp concentration (AF16-N)
- Filter control, oil in water (TF16-N)

See our TOP 5 brochures for applications in your industry.



optek TF16-EX-HT-N
Scattered Light Dual Channel Turbidity Sensor



Turbidity Sensors AF16-N/TF16-N | 13

Technical Data	AF16-N (Turbidity)	TF16-N (Turbidity)
Measurement		
Measurement principle	1- Channel absorption of light	1- Channel absorption of light and 2- Channel scattering of light (11°)
Measurement wavelength	730 nm - 970 nm	730 nm - 970 nm
Detector(s)	1 silicon photodiode (hermetically sealed)	1 silicon photodiode (hermetically sealed) (Abs.) 8 silicon photodiodes (hermetically sealed) (11°)
Measuring range NIR-Absorption	any measuring range between 0 - 0.05 to 6 CU 0 - 50 to 40,000 ppm (DE) 0 - 20 to 16,000 FTU 0 - 5 to 4,000 EBC	any measuring range between 0 - 0.05 to 5 CU 0 - 50 to 8,000 ppm (DE) 0 - 20 to 3,200 FTU 0 - 5 to 800 EBC
Measuring range Scattered Light (11°)	n/a	any measuring range between 0 - 0.5 to 500 ppm (DE) 0 - 0.2 to 200 FTU 0 - 0.05 to 50 EBC (higher [i.e. 100 EBC] with reduced resolution, accuracy)
Optical path length	1 - 1000 mm	40 mm standard (10 - 60 mm with reduced accuracy)
Calibration	Abs.: CU (concentration units) application specific calibration	Abs.: CU (concentration units) application specific calibration basic calibration 11°: in ppm (DE) / FTU / EBC
Light source	special incandescent tungsten lamp 5.0 V DC, 970 mA typical life span: 3 to 5 years (25,000 to 40,000 hours)	
Resolution	< ± 0.05 % of respective measuring range	
Repeatability	< ± 0.5 % of respective measuring range (scattered light < ± 0.3 %)	
Linearity	< ± 1 % of respective measuring range (specific to application)	
Protection	all optical parts have an IP rating of IP65 or higher	
Sensor Body		
Material	Stainless steel 1.4435 (SS 316L), 1.4539, 1.4571 (SS 316Ti), 1.4462, Titanium 3.7035 (Grade 2), Hastelloy 2.4602 (C22), Plastic TFM4215, PVC, ... others on request	
Line size	1/8 in. to 6 in. (DN 6 to DN 150), ... others on request	
Process connection	Flanges (ASME, DIN, JIS), Clamps (TC, ISO, DIN), Female Threads (NPT, DIN), Sanitary Threads (DIN 11851), Tube Ends (DIN, ISO, OD), Varivent, ... others on request	
Process pressure	10 mbar to 100 bar (0.15 psi to 1450 psi) - higher on request depending on process connection, materials and design	
Windows	1-Pyrex®, 2-Sapphire, 3-Sapphire Biotech	
Window gaskets	Silicone (FDA), Viton® (FDA), EPDM (FDA / USP Class VI), Kalrez® 4079, ... others on request	
Temperature Ratings		
Process temperature	permanent: 0 - 120 °C (32 - 248 °F) / peak 15 min/day: 0 - 150 °C (32 - 302 °F)	
Process temperature OPTION HT	permanent: -30 - 240 °C (-22 - 464 °F) / peak 15 min/day: -30 - 260 °C (-22 - 500 °F)	
Process temperature OPTION EX	permanent: -30 - 120 °C (-22 - 248 °F) / peak 15 min/day: -30 - 150 °C (-22 - 302 °F)	
Process temperature OPTION EX-HT	permanent: -30 - 240 °C (-22 - 464 °F) / peak 15 min/day: -30 - 260 °C (-22 - 500 °F)	
Ambient temperature	operation: 0 - 40 °C (32 - 104 °F) operation: -30 - 40 °C (-22 - 104 °F) with options HT / EX / EX-HT transport: -20 - 70 °C (-4 - 158 °F)	
Explosion Proof		
Ex-proof	none	
Ex-proof OPTION EX (EN-D)	Sensor assembly in ex-proof version acc. ATEX (EN-D)	Approval: DMT 02 ATEX E 175 X Approval: DMT 02 ATEX E 176 X
Ex-proof OPTION EX (FM-D)	Sensor assembly in ex-proof version acc. FM (FM-D)	Approval: FMG J. I. 3013884
Calibration		
Calibration adapter	none	n/a
Calibration adapter OPTION VB - recommended -	Filter adapter FH03 (detector side) for calibration filter used for sensor verification	n/a

Pressure and temperature ratings specified herein may be subject to limitations - see instruction manual.
The appropriate choice of material for all wetted parts is the sole responsibility of the user.
Data given are subject to changes without prior notice.

14 | Color Sensors AF16-F/AF26

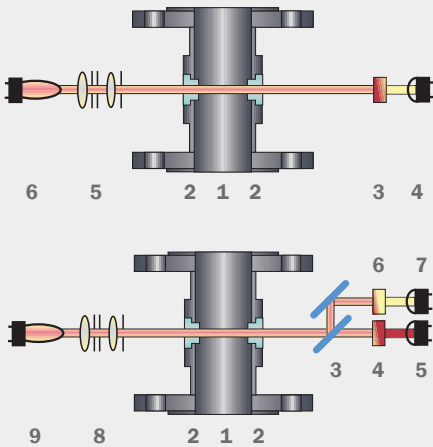

3 Model AF16-F Single Channel Absorption (VIS)

- | | |
|-----------------|------------------------|
| 1 Sensor body | 2 Windows |
| 3 Filter | 4 Measurement detector |
| 5 Optics module | 6 Lamp module |

4 Model AF26 Dual Channel Absorption (VIS-NIR)

- | | |
|--------------------------|-----------------|
| 1 Sensor body | 2 Windows |
| 3 Beam splitter | 4 Filter A |
| 5 Measurement detector A | 6 Filter B |
| 7 Measurement detector B | 8 Optics module |
| 9 Lamp module | |

Models AF16-F and AF26 are high precision color sensors used to measure color or color changes in various industries. The sensors are designed for inline operation and provide accurate concentration measurements with remarkable repeatability, linearity and resolution.

Modular construction of the sensors offers maximum flexibility in adapting to various process needs. Options include electro-polished sensor bodies, hazardous location (explosion-proof) capability, chemical resistant materials (sapphire windows, titanium, Hastelloy, etc.) and high temperature or high pressure versions.

VIS-Absorption (Color)

A special tungsten lamp produces a constant light beam that passes through the process medium. The attenuation of the light intensity, caused by absorption and/or scattering by dissolved and undissolved substances, is detected by sealed silicon photodiodes.

At a specific wavelength in the visible range (385 - 670 nm) there is a loss of light as a result of an increase in color depth. optek sensors measure in various color scales such as Hazen, APHA, ASTM, EBC, Gardner, Saybolt, and many more. Also, many dissolved substances in liquids can be precisely

monitored using color measurements. For instance, increasing iron or nickel contents result in a yellow liquid.

OPL

Special optical windows are made from a single crystal sapphire, providing superior resistance to all abrasive and corrosive media. With the appropriate choice of sensor bodies and windows in various lengths, the optimal OPL (optical path length = distance between the windows) can be achieved to meet the measurement requirements, i.e., low/high measuring ranges at highest resolution.

Dual Wavelengths

Selected combinations of optical filters make it possible to focus on specific wavelengths ensuring suitable adaptation to the application. While the AF16-F uses one wavelength, an AF26 is equipped with an internal beam splitter making it possible to measure two wavelengths simultaneously.

Connected to optek Control 4000 or Control 8000 converters, the second

wavelength can be used to compensate for (varying) background turbidity and any lamp intensity variation to assure the highest level of precision and long-term performance. Combined with a long optical path length, even the smallest color changes can be measured.

NIST-traceable

NIST-traceable calibration accessories provide absolute measurement confidence (for details refer to page 27).

Typical Applications:

- Monitoring in various color scales 0-10 to 0-500 APHA Hazen, 30 to -16 Saybolt, 0-1 to 0-8 ASTM etc.
- Measuring various concentrations 0-100mg/l chlorine, 0-5mg/l iron in hydrochloric acid, 0-100% chlorine gas, 0-10 ppm to 0-15g/l chlorine dioxide

See our **TOP 5 brochures for applications in your industry.**

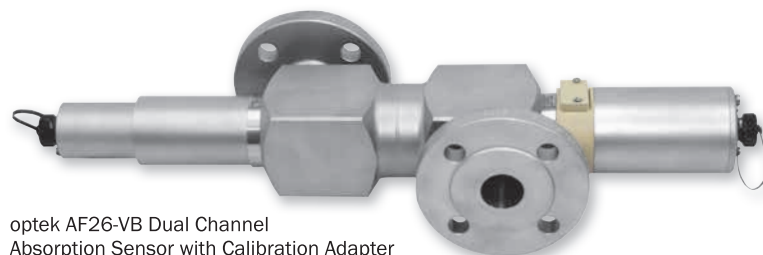

optek AF26-VB Dual Channel Absorption Sensor with Calibration Adapter



Technical Data	AF16-F (Color)	AF26 (Color)
Measurement		
Measurement principle	1- Channel absorption of light	2- Channel absorption of light
Measurement wavelength(s)	385, 400, 430, 525, 750, 1000 nm, others on request	385/430, 385/550, 385/620, 400/550, 400/620, 420/700, 430/525, 430/620, 430/700, 460/620, 470/620, 470/700, 525/620, 525/700, 550/800, 620/800, 660/750, 670/550, 670/750, 1000/800 nm, others on request
Detector(s)	1 silicon photodiode (hermetically sealed)	2 silicon photodiodes (hermetically sealed)
Measuring range	any measuring range between 0 - 0.05 to 2.8 CU (dependent on filter used) <i>contact product specialist for application specific ranges</i>	any measuring range between 0 - 0.05 to 3 CU (dependent on filter used) <i>contact product specialist for application specific ranges</i>
Optical path length	1 - 1000 mm	
Calibration	CU (concentration units) application specific calibration	
Light source	special incandescent tungsten lamp 5.0 V DC, 970 mA typical life span: 3 to 5 years (25,000 to 40,000 hours)	
Resolution	< ± 0.05 % of respective measuring range	
Repeatability	< ± 0.5 % of respective measuring range	
Linearity	< ± 1 % of respective measuring range (specific to application)	
Protection	all optical parts have an IP rating of IP65 or higher	
Sensor Body		
Material	Stainless steel 1.4435 (SS 316L), 1.4539, 1.4571 (SS 316Ti), 1.4462, Titanium 3.7035 (Grade 2), Hastelloy 2.4602 (C22), Plastic TFM4215, PVC, ... others on request	
Line size	1/8 in. to 6 in. (DN 6 to DN 150), ... others on request	
Process connection	Flanges (ASME, DIN, JIS), Clamps (TC, ISO, DIN), Female Threads (NPT, DIN), Sanitary Threads (DIN 11851), Tube Ends (DIN, ISO, OD), Varivent, ... others on request	
Process pressure	10 mbar to 100 bar (0.15 psi to 1450 psi) - higher on request depending on process connection, materials and design	
Windows	1-Pyrex®, 2-Sapphire, 3-Sapphire Biotech	
Window gaskets	Silicone (FDA), Viton® (FDA), EPDM (FDA / USP Class VI), Kalrez® 4079, ... others on request	
Temperature Ratings		
Process temperature	permanent: 0 - 120 °C (32 - 248 °F) / peak 15 min/day: 0 - 150 °C (32 - 302 °F)	
Process temperature OPTION HT	permanent: -30 - 240 °C (-22 - 464 °F) / peak 15 min/day: -30 - 260 °C (-22 - 500 °F)	
Process temperature OPTION EX	permanent: -30 - 120 °C (-22 - 248 °F) / peak 15 min/day: -30 - 150 °C (-22 - 302 °F)	
Process temperature OPTION EX-HT	permanent: -30 - 240 °C (-22 - 464 °F) / peak 15 min/day: -30 - 260 °C (-22 - 500 °F)	
Ambient temperature	operation: 0 - 40 °C (32 - 104 °F) operation: -30 - 40 °C (-22 - 104 °F) with options HT / EX / EX-HT transport: -20 - 70 °C (-4 - 158 °F)	
Explosion Proof		
Ex-proof	none	
Ex-proof OPTION EX (EN-D)	Sensor assembly in ex-proof version acc. ATEX (EN-D)	Approval: DMT 02 ATEX E 175 X Approval: DMT 02 ATEX E 176 X
Ex-proof OPTION EX (FM-D)	Sensor assembly in ex-proof version acc. FM (FM-D)	Approval: FMG J. I. 3013884
Calibration		
Calibration adapter	none	
Calibration adapter OPTION VB - recommended -	Filter adapter FH03 (detector side) for calibration filter used for sensor verification	

Pressure and temperature ratings specified herein may be subject to limitations - see instruction manual.
The appropriate choice of material for all wetted parts is the sole responsibility of the user.
Data given are subject to changes without prior notice.

16 | UV Sensors AF45/AF46

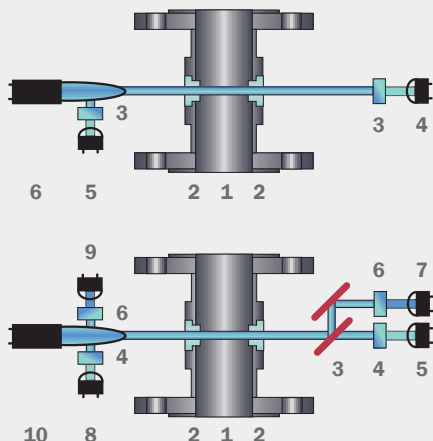

5 Model AF45 Single Channel Absorption (UV)

- | | |
|----------------------|-------------------------|
| 1 Sensor body | 2 Windows |
| 3 Filter | 4 Measurement detector |
| 5 Reference detector | 6 Lamp module (mercury) |

6 Model AF46 Dual Channel Absorption (UV)

- | | |
|--------------------------|--------------------------|
| 1 Sensor body | 2 Windows |
| 3 Beam splitter | 4 Filter A |
| 5 Measurement detector A | 6 Filter B |
| 7 Measurement detector B | 8 Reference detector A |
| 9 Reference detector B | 10 Lamp module (mercury) |

Models AF45 and AF46 are high precision UV absorption sensors for use in the biotech and chemical industries. The sensors are designed for inline operation and provide accurate concentration measurements with remarkable repeatability, linearity and resolution.

Modular construction of the sensors offers maximum flexibility in adapting to various process needs. Options include electro-polished sensor bodies, hazardous location (explosion-proof) capability, chemical resistant materials (sapphire windows, titanium, Hastelloy, etc.) and high temperature or high pressure versions.

UV-Absorption

A special mercury lamp produces a constant light beam that passes through the process medium. The attenuation of the light intensity, caused by absorption and/or scattering by dissolved and undissolved substances, is detected by sealed silicon photodiodes.

The light intensity of the lamp itself is measured by sealed silicon photodiodes using the same filter as the measurement wavelength. The sealed silicon photodiodes also compensate for any variances in lamp intensity, assuring the highest level of precision and long-term performance. Specific lamp design and capability of optek

converters operating with lowest photocurrents provide a prolonged life span at the lowest cost of ownership.

OPL

Special optical windows are made from a single crystal sapphire, providing superior resistance to all abrasive and corrosive media. With the appropriate choice of sensor bodies and windows in various lengths, the optimal OPL (optical path length = distance between the windows) can be achieved to meet the measurement requirements, i.e., low/high measuring ranges at highest resolution.

Dual Wavelengths

Selected combinations of optical filters make it possible to focus on specific wavelengths. Different peak wavelengths are available with a variety of bandwidth options ensuring suitable adaptation to the application.

While the AF45 uses one wavelength, an AF46 is equipped with an internal beam splitter making it possible to measure two wavelengths simultaneously. Connected to an optek Control 4000 or Control 8000 converter, a wide dynamic range is possible to measure at high and low values with one sensor in one setup. This ensures minimal hold-up volume and installation cost.

NIST-traceable

NIST-traceable calibration accessories provide absolute measurement confidence (for details refer to page 27).

Typical Applications:

- Monitoring of chromatographic columns (i.e., protein concentration)
- Measuring concentrations of aromatics

See our TOP 5 brochures for applications in your industry.

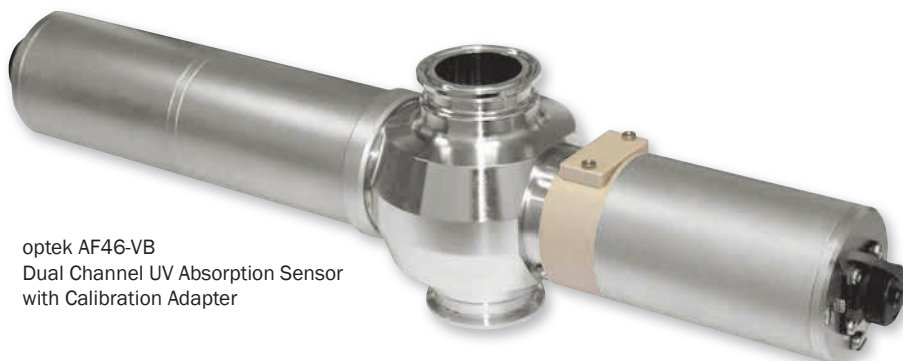

optek AF46-VB
Dual Channel UV Absorption Sensor
with Calibration Adapter

Technical Data	AF45 (UV)	AF46 (UV)
Measurement		
Measurement principle	1- Channel absorption of light	2- Channel absorption of light
Measurement wavelength(s)	254-13, 280-09, 280-13, 290-13, 300-13, 313-13 nm, ... others on request	254-13 / 280-13, 254-13 / 313-13, 280-09 / 300-05, 280-09 / 300-13, 280-09 / 313-13, 280-13 / 300-13, 280-13 / 313-13, 290-13 / 313-13 nm, ... others on request
Measuring detector(s)	1 silicon photodiode (hermetically sealed)	2 silicon photodiodes (hermetically sealed)
Reference detector(s)	1 silicon photodiode (hermetically sealed)	2 silicon photodiodes (hermetically sealed)
Measuring range	any measuring range between 0 - 0.05 to 3 CU (dependent on filter used/ OPL) (contact product specialist for application specific ranges)	any measuring range between 0 - 0.05 to 2 CU (dependent on filter used/ OPL) (contact product specialist for application specific ranges)
Optical path length	1- 160 mm	
Calibration	CU (concentration units) application specific calibration	
Light source	low pressure mercury lamp typical life span: 1 to 2 years (8,000 to 16,000 hours)	
Resolution	< ± 0.05 % of respective measuring range	
Repeatability	< ± 0.5 % of respective measuring range	
Linearity	< ± 1 % of respective measuring range (specific to application)	
Protection	all optical parts have an IP rating of IP65 or higher	
Sensor Body		
Material	Stainless steel 1.4435 (SS 316L), 1.4539, 1.4571 (SS 316Ti), 1.4462, Titanium 3.7035 (Grade 2), Hastelloy 2.4602 (C22), Plastic TFM4215, PVC, ... others on request	
Line size	1/8 in. to 6 in. (DN 6 to DN 150), ... others on request	
Process connection	Flanges (ASME, DIN, JIS), Clamps (TC, ISO, DIN), Female Threads (NPT, DIN), Sanitary Threads (DIN 11851), Tube Ends (DIN, ISO, OD), Varivent, ... others on request	
Process pressure	10 mbar to 100 bar (0.15 psi to 1450 psi) - higher on request depending on process connection, materials and design	
Windows	2-Sapphire, 3-Sapphire Biotech (do not use Pyrex®)	
Window gaskets	Viton® (FDA), EPDM (FDA / USP Class VI), Kalrez® 4079, ... others on request (do not use Silicone)	
Temperature Ratings		
Process temperature	permanent: 0 - 70 °C (32 - 158 °F) / peak 15 min/day: 0 - 135 °C (32 - 275 °F)	
Process temperature OPTION HT	permanent: -30 - 120 °C (-22 - 248 °F) / peak 15 min/day: -30 - 150 °C (-22 - 302 °F)	
Process temperature OPTION EX	permanent: -30 - 70 °C (-22 - 158 °F) / peak 15 min/day: -30 - 135 °C (-22 - 275 °F)	
Process temperature OPTION EX-HT	permanent: -30 - 120 °C (-22 - 248 °F) / peak 15 min/day: -30 - 150 °C (-22 - 302 °F)	
Ambient temperature	operation: 0 - 40 °C (32 - 104 °F) operation: -30 - 40 °C (-22 - 104 °F) with options HT / EX / EX-HT transport: -20 - 70 °C (-4 - 158 °F)	
Explosion Proof		
Ex-proof	none	
Ex-proof OPTION EX (EN-D)	Sensor assembly in ex-proof version acc. ATEX (EN-D)	Approval: DMT 02 ATEX E 175 X Approval: DMT 02 ATEX E 176 X
Ex-proof OPTION EX (FM-D)	Sensor assembly in ex-proof version acc. FM (FM-D)	Approval: FMG J. I. 3013884
Calibration		
Calibration adapter VB	Filter adapter FH03 (detector side) for calibration filter used for sensor verification	

Pressure and temperature ratings specified herein may be subject to limitations - see instruction manual.
The appropriate choice of material for all wetted parts is the sole responsibility of the user.
Data given are subject to changes without prior notice.

18 | Probe Sensors AS16/AS56

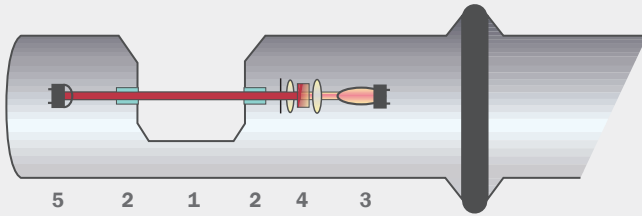

② Model AS16 (AS56) Single Channel Absorption

- 1 OPL
- 2 Windows
- 3 Lamp module
- 4 Optics modules (incl. filter)
- 5 Detector module

No window gaskets used

Models AS16 and AS56 are high precision sensors measuring turbidity (AS16-N and AS56-N) or color (AS16-F and AS56-F) for use in various industries. The sensors are designed for inline operation and provide accurate concentration measurements with remarkable repeatability, linearity and resolution.

AS16

The AS16 series offers the high-end range of optek probe sensors. A wide selection of different optical path lengths and insertion depths combined with optional calibration filters and electro-polished stainless steel meet all requirements of the biotechnology industry.

AS56

The AS56, based on the same design as the AS16 with seal-less window construction, is typically used in food and beverage applications. Limited variations allow cost effective measurement (e.g., phase separation).

NIR-Absorption (Turbidity) VIS-Absorption (Color)

A special tungsten lamp produces a constant light beam that passes through the process medium. The attenuation of the light intensity, caused by absorption and/or scattering by dissolved and undissolved substances, is detected by a sealed silicon photo-

diode. The AS16-N and AS56-N uses light from 730 - 970 nm to measure solids concentration independent from color or color changes (e.g., yeast concentration in beer during tank draining).

The AS16-F and AS56-F uses a specific wavelength in the visible spectrum to measure color in liquids with little or no turbidity (e.g., beer in water during phase change).

OPL

Special optical windows are made from a single crystal sapphire, providing superior resistance to all abrasive and corrosive media. optek's superior manufacturing techniques allow mounting the windows without gaskets or glue for lifetime without maintenance. The appropriate choice of the optimal OPL (optical path length = distance between the windows) supports all measurement requirements, i.e., low/high measuring ranges at highest resolution.

NIST-traceable

NIST-traceable calibration accessories (AS16 only) provide absolute measurement confidence (for details refer to page 27).

Typical Applications:

- Cell density in fermentation (AS16-N)
- Milk/water phase separation (AS56-N)
- Beverage blending (AS16-F)
- Beer/water phase separation (AS56-F)

See our TOP 5 brochures for applications in your industry.



optek AS16-VB-N Single Channel Absorption Probe



optek AS16-VB-N Single Channel Absorption Probe with Calibration Adapter

Technical Data	AS16	AS56
Measurement		
Measurement principle	1- Channel absorption of light	
Detector	1 silicon photodiode (hermetically sealed)	
Measurement wavelength	<ul style="list-style-type: none"> AS16-N: 730 - 970 nm AS16-F: 430, 550 or 620 nm 	<ul style="list-style-type: none"> AS56-N: 730 - 970 nm AS56-F: 430 nm
Measuring range	AS16-N: any measuring range between 0 - 0.05 to 6 CU AS16-F: any measuring range between 0 - 0.05 to 2 CU (depending on wavelength)	AS56-N: any measuring range between 0 - 0.05 to 4 CU AS56-F: any measuring range between 0 - 0.05 to 1.5 CU
Optical path length	1, 5, 10, 20 or 40 mm	5 or 10 mm
Calibration	CU (concentration units) application specific calibration	
Light source	special incandescent tungsten lamp 5.0 V DC, 970 mA typical life span: 3 to 5 years (25,000 to 40,000 hours)	special incandescent tungsten lamp 5.0 V DC, 450 mA typical life span: 3 to 5 years (25,000 to 40,000 hours)
Resolution	< ± 0.05 % of respective measuring range	< ± 0.5 % of respective measuring range
Repeatability	< ± 0.5 % of respective measuring range	< ± 1.0 % of respective measuring range
Linearity	< ± 1 % of respective measuring range (specific to application)	< ± 2 % of respective measuring range (specific to application)
Protection	all optical parts have an IP rating of IP65 or higher	
Process Adaption		
Material	wetted parts: stainless steel 1.4435 (SS 316 L) dF < 1 %, BN2 surface: electro-polished Ra < 0.4 µm housing: stainless steel 1.4571 (SS 316 Ti)	wetted parts: stainless steel 1.4435 (SS 316 L) surface: electro-polished Ra < 0.8 µm housing: stainless steel 1.4571 (SS 316 Ti)
Port connection	thread G1-1/4 in., ISO 228/1 for port AS25 (similar Ingold-port) diameter: 25 mm (D= 25 H7) O-ring groove for 30 mm and for 60 mm port length	
Port gasket	O-ring 18.64 x 3.53 mm EPDM (FDA / USP Class VI)	
Insertion depth	35 mm (1.38 in.) + OPL at a port length of 60 mm (2.36 in.) 135 mm (5.31 in.) + OPL at a port length of 60 mm (2.36 in.)	35 mm (1.38 in.) + OPL at a port length of 60 mm (2.36 in.) n/a
Process pressure	10 mbar to 20 bar (0.15 psi to 290 psi)	10 mbar to 10 bar (0.15 psi to 145 psi)
Windows	sapphire (seal-less)	
Window gaskets	n/a	
Installation accessories	weld-in ports, Varivent adapter (50.00), clamp adapter (1.5 and 2.0 in.) optek T-pieces DIN 11850 (DN50 - DN100), optek T-pieces OD (BS4821-1) (2.0 - 4.0 in.)	
Temperature Ratings		
Process temperature	permanent: 0 - 100 °C (32 - 212 °F) peak 60 min/day: 0 - 150 °C (32 - 302 °F)	permanent: 0 - 90 °C (32 - 194 °F) peak 60 min/day: 0 - 100 °C (32 - 212 °F)
Ambient temperature	operation: 0 - 40 °C (32 - 104 °F) transport: -20 - 70 °C (-4 - 158 °F)	
Calibration		
Calibration adapter VB	Filter adapter FH03 for calibration filter used for sensor verification	n/a

Pressure and temperature ratings specified herein may be subject to limitations - see instruction manual.
The appropriate choice of material for all wetted parts is the sole responsibility of the user.
Data given are subject to changes without prior notice.

Installation accessories:



Tri-Clamp



Varivent



Weld-in port 15°



Weld-in port 0°



T-piece

20 | Probe Sensors ASD12-N / ASD25-N

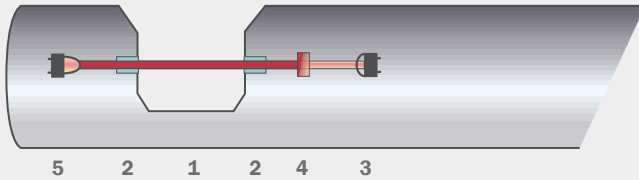

① Model ASD

- | | |
|--------------------|--------------------|
| 1 OPL | 2 Sapphire windows |
| 3 Detector | 4 Daylight filter |
| 5 LED light source | |

No window gaskets used

The ASD12-N and ASD25-N absorption sensors are designed for use in pilot and production scale fermenters or bioreactors to precisely measure the growth of microbial or cell cultures as a function of NIR absorption.

NIR-Absorption

A precisely defined and constant LED light beam penetrates the process medium. ASD12-N and ASD25-N use light from 840 nm to 910 nm (NIR). The attenuation of the light intensity, caused by absorption by dissolved substances and undissolved material is detected by a hermetically sealed photodiode.

ASD12-N

The ASD12-N probe is specifically engineered for use in laboratory fermenters. The seal-less sapphire window design eliminates crevices and gaps to assure the highest level of sterility. All wetted parts are electro-polished steel. The ASD12-N is autoclavable and mounts conveniently through any head-plate with a PG13.5 threaded port. The ASD12-N is available in three different insertion depths with either 1, 5 or 10 mm OPLs (optical path length = distance between the windows). Shorter optical path lengths are typically used for dense cell cultures such as bacterial and yeast cultures. Longer OPLs are used for less dense cell cultures e.g., mammalian cells and dissolution / precipitation / crystallization reactions.

ASD25-N / ASD25-BT-N

Models ASD25-N and ASD25-BT-N are designed for use in pilot or production scale fermenters or bioreactors. These extremely durable probes are designed for sanitary bioprocess environments and can be used in CIP/ SIP processes.

The ASD25-N is conveniently mounted through a standard 25 mm Ingold - type port and the ASD25-BT-N through a standard 25 mm safety port.

Typical Applications:

- Cell growth in mammalian cell cultures and bacterial fermentation
- Algae concentration monitoring
- Biomass concentrations
- Crystallization process monitoring

See our **TOP 5 brochures for applications in your industry.**



Sapphire windows (seal-less)



optek ASD12-N
Single Channel Absorption Probes

Probe Sensors ASD12-N / ASD25-N | 21

Technical Data	ASD12-N	ASD25-N	ASD25-BT-N
Measurement			
Measurement principle	1-Channel absorption of light		
Detector	1-Silicon photodiode (hermetically sealed)		
Measurement wavelength	840 nm - 910 nm		
Measuring range	any measuring range between: 0 - 0,05 to 4 CU		
Optical path length	1, 5 or 10 mm	1, 5, 10 or 20 mm	
Calibration	CU (concentration units) application specific calibration		
Light source	Hybrid LED (hermetically sealed), 5.4 V DC, 100 mA, typical life span: approx 10 years		
Protection	IP68	IP65	
Process Adaption			
Material	wetted parts: stainless steel 1.4435 (SS 316L) dF < 1%, BN2 surface: electro-polished Ra < 0.4 µm		
Port connection	Fermenter head plates diameter: 12 mm thread: PG 13.5	OSP25-GS60 (similar Ingold-port) nominal length: 60 and 30 mm diameter: 25 mm thread: G1-1/4 in. ISO 228/1	OSP25-GS52 (similar safety- port) nominal length: 52 and 30 mm diameter: 25 mm thread: G1-1/4 in. ISO 228/1
Port gasket	O-ring 11.00 x 3.00 mm EPDM (FDA / USP Class VI)	O-ring 18.64 x 3.53 mm EPDM (FDA / USP ClassVI), others on request	
Insertion depth	110 mm + OPL 215 mm + OPL 315 mm + OPL others on request	35 mm + OPL with port length 60 mm	35 mm + OPL with port length 52 mm
Process pressure	pressure-free (+/- 0.5 bar) (+/- 7.25 psi)	10 mbar to 10 bar (0.15 psi to 145 psi)	
Windows	Sapphire (seal-less)		
Installation accessories	Adapter PG 13.5 Variable depth Adapter M 26 x 1 - PG 13.5	weld-in ports, Varivent adapter (50.00), clamp adapter, optek T-pieces DIN 11850, optek T-pieces OD (BS4821-1)	weld-in ports
Temperature Ratings			
Process temperature	permanent: 5 - 50 °C (41 - 122 °F)	permanent: 5 - 65 °C (41 - 149 °F) peak (60 min./day): 5 - 135 °C (41 - 275 °F) thermal shutdown at approximately 75 °C (167 °F)	
Ambient temperature	operation: 0 - 40 °C (32 - 104 °F) transport: -20 - 70 °C (-4 - 158 °F)		
Sterilization conditions	Sterilization must be performed outside the process and the ASD must be discon- nected from the power source (autoclaving possible without cable) max. pressure: 4 bar (58 psi) max. temperature: 135 °C (275 °F) (max. 60 min./day)		Autoclaving not possible

Pressure and temperature ratings specified herein may be subject to limitations - see instruction manual.
The appropriate choice of material for all wetted parts is the sole responsibility of the user.
Data given are subject to changes without prior notice.

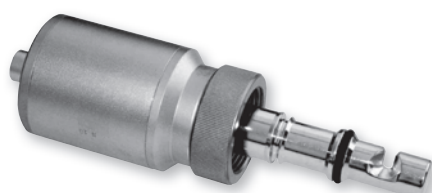

optek ASD25-N
Single Channel Absorption Probe



optek ASD25-BT-N
Single Channel Absorption Probe

22 | Conductivity Sensors ACF60 / ACS60



- Patented six-electrode design reduces sensitivity to fouling and polarization
- Wide measuring range: 0 - 10 $\mu\text{S}/\text{cm}$ up to 0 - 850 mS/cm
- Integrated Pt1000 temperature sensor
- No O-rings or epoxy - suitable for CIP/SIP

Six-Electrodes

The ACF60/ACS60 conductivity sensor features a superior six-electrode, four-pole design. The patented arrangement of the four current electrodes around the two potential electrodes results in a reliable and precise measurement. This unique design also provides greatly reduced sensitivity to sensor fouling and polarization. The combination of optek C8000 universal converter and ACF60/ACS60 conductivity sensors allow a wide dynamic range from 0 - 10 $\mu\text{S}/\text{cm}$ up to 0 - 850 mS/cm with the same sensor.

Temperature Measurement

The integrated Pt1000 platinum RTD in the tip of the ACF60/ACS60 sensor provides fast-response temperature measurement for compensation, which can be displayed and transmitted from the C8000 converter.

Sanitary Design

Designed for ultra-sterility, the six electrodes are sealed in the FDA (USP class VI) compliant PEEK sensor tip without the use of O-rings or epoxy. The ACF60/ACS60 sensor is suitable for CIP/SIP applications.

ACF60

Mounted in an optek inline sensor body, the design ensures smooth and unrestricted flow of all process fluids with minimized hold-up and hydrostatic shear.



ACF60
Conductivity Sensor



ACS60
Conductivity Sensor

Technical Data	ACF60	ACS60-35-60
Material (wetted)	PEEK (FDA, USP class VI) electrodes: • Stainless Steel 1.4435 (SS316 L), df < 1%, BN2 • Hastelloy 2.4602 Hastelloy C22	
Port-gaskets	O-ring: EPDM (FDA, USP Class VI), ... others on request	
Line size	1/8 in. to 6 in. (DN 6 to DN 150), ... others on request	
Port connection		OSP25-GS60 (similar Ingold-port) nominal length: 60 mm diameter: 25 mm thread: G1-1/4 in. ISO 228/1
Installation accessories		weld-in ports, Varivent adapter 50.00), clamp adapter, optek T-pieces DIN 11850, optek T-pieces OD (BS4821-1)
Process pressure	20 bar (290 psi) - 50 °C (122 °F) 10 bar (145 psi) - 100 °C (212 °F) 4 bar (58 psi) - 135 °C (275 °F)	
Process temperature	permanent: -10 - 90 °C (14 - 194 °F) peak 30 min/day: -10 - 135 °C (14 - 275 °F)	
Ambient temperature	operation: -10 °C - 40 °C (14 °F - 104 °F) transport: -20 °C - 70 °C (-4 °F - 158 °F)	
Temperature sensor	integrated Pt1000 RTD (IEC Class A) accuracy: ± 0.25 °C at 25 °C (77 °F)	
Protection	IP65	
Measuring range	any measuring range between 0 - 10 $\mu\text{S}/\text{cm}$ to 850 mS/cm	

	Accuracy	Repeatability
0 - 10 $\mu\text{S}/\text{cm}$	calibrated: $\pm 1\%$ of measuring value ± 0.2 $\mu\text{S}/\text{cm}$ uncalibrated: $\pm 3\%$ of measuring value ± 0.2 $\mu\text{S}/\text{cm}$	$\pm 0.5\%$
0 - 250 mS/cm	calibrated: $\pm 1\%$ of measuring value ± 0.2 $\mu\text{S}/\text{cm}$ uncalibrated: $\pm 3\%$ of measuring value ± 0.2 $\mu\text{S}/\text{cm}$	$\pm 0.5\%$
250 - 500 mS/cm	calibrated: $\pm 2\%$ of measuring value ± 0.2 $\mu\text{S}/\text{cm}$ uncalibrated: $\pm 6\%$ of measuring value ± 0.2 $\mu\text{S}/\text{cm}$	$\pm 1\%$
500 - 850 mS/cm	calibrated: $\pm 5\%$ of measuring value ± 0.2 $\mu\text{S}/\text{cm}$ uncalibrated: $\pm 12\%$ of measuring value ± 0.2 $\mu\text{S}/\text{cm}$	$\pm 3\%$

Pressure and temperature ratings specified herein may be subject to limitations - see instruction manual. The appropriate choice of material for all wetted parts is the sole responsibility of the user. Data given are subject to changes without prior notice.



- 12-degree electrode orientation provides improved performance
- pH electrode solution ground allows inline diagnostics
- Designed to enhance flow and minimize hold-up volume
- Suitable for most \varnothing 12 x 120 mm pH-electrodes

12 Degree

The optek PF12 pH electrode adapter is designed to mount pH electrodes at the optimal angle of 12 degrees. This allows the sensor to use electrolyte-filled glass electrodes and improves the functionality and life span of the pH electrodes. The PF12 electrode adapter is compatible with a broad variety of pH electrodes.

Solution Ground

The PF12 is equipped with a solution ground (earth) connection mounted to the sensor body. This allows the use of pH electrodes that incorporate differential pH input techniques. Additionally, the solution earth connection provides a highly stable measurement while enabling sensor diagnostics including low glass impedance, out-of sample, and broken electrode/cable warnings.

Sanitary Design

Mounted in an optek inline sensor body, the design of the PF12 ensures smooth and unrestricted flow of all process fluids. The PF12 meets sterility requirements and is compatible with CIP/SIP while minimizing hold-up volume and hydrostatic shear.



PF12
pH Electrode Holder



ACF60

PF12

Technical Data	PF12
Material	Stainless steel 1.4435 (SS 316L), dF < 1 %, BN2
Material (wetted)	<ul style="list-style-type: none"> • Stainless Steel 1.4435 (SS316 L), dF < 1%, BN2 or • Hastelloy 2.4602 Hastelloy C22
Surface	electro polished (Ra < 0.4 μ m)
Solution ground	female SA483 for solution ground plug
Line size	1/8 in. to 6 in. (DN 6 to DN 150), ... others on request
Electrode types	suitable for wide variety of electrodes with dimensions \varnothing 12 x 120 mm, PG 13.5 thread
Process temperature	-10 °C - 135 °C (14 °F - 275 °F)
Process pressure	6 bar (87 psi)

pH and conductivity measurement combined for low hold-up volume

Line Size	Volume	Volume
	cond. only	pH + cond.
0.25 in.	< 22 ml	< 41 ml
0.50 in.	< 26 ml	< 44 ml
0.75 in.	< 34 ml	< 52 ml
1.00 in.	< 48 ml	< 65 ml

Pressure and temperature ratings specified herein may be subject to limitations - see instruction manual. The appropriate choice of material for all wetted parts is the sole responsibility of the user. Data given are subject to changes without prior notice.

24 | Single Use Cell (S.U.C.)



- Same performance as conventional systems
- Compatible with various optek sensors
- Reduced risk of contamination
- Four measurements in one Single Use Cell
- Minimized hold-up volume
- USP Class VI and FDA approval

The Single Use Cell (S.U.C.) is designed to optimize separation, purification, concentration and formulation processes in disposable chromatography and ultrafiltration systems. Cross-contamination between products and batches will no longer be an issue as gamma irradiated Single Use Cells decrease the risk of contamination to virtually zero.

S.U.C. Design

The S.U.C. is available in four different designs. Two versions are primarily for pre-column chromatography measurements (SUC 01/03) and two versions for post-column measurements (SUC 05/07) with optical windows for optek UV sensors. Each S.U.C. is clearly labeled with data specific to that particular cell. This data includes the sensor constant of the conductivity sensor, as well as the UV OPL (optical path length) adaptation data (for SUC 05/07).

S.U.C. Holder

Integral parts of the S.U.C. system include the holder and locking mechanism guaranteeing proper installation. To enable easy and fast installation into the process instrumentation, the S.U.C. holder comes equipped with the conductivity sensor ACF60-SU-35.

S.U.C. pH Adapter

SUC 03 and SUC 07 are equipped with the pH adapter, which is compatible with a broad variety of standard pH electrodes (Ø12 mm x 120 mm). When no pH adapter is required (for SUC 01 and SUC 05) a plug is used to cover the pH input. This pH plug has the same dimensions as the pH electrode, keeping the hold-up volume minimal.

S.U.C. (Single Use Cells)

The versatile design of the optek S.U.C. has been developed to meet the specific demands of biopharmaceutical manufacturing (see tables on page 25 for details). With low hold-up volumes and easy installation they are fully compatible with the optek range of UV, NIR and color absorption sensors.



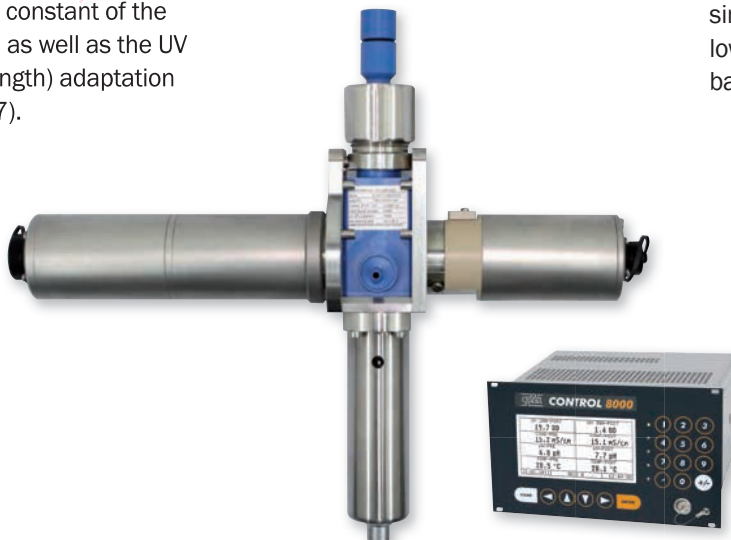

- The Single Use Cells are manufactured in a clean room facility and are gamma irradiation ready
- Simple fast exchange of the S.U.C. eliminates the need for system cleaning and validation
- Improved productivity due to simpler exchange procedures and low down time between products/batches



- 8 Measurements
- 5 Sensors
- 2 Single Use Cells
- 1 Converter

Technical Data	S.U.C. Holder Including ACF60-SU-35
Material (non wetted)	SS 316 L
Measuring range	0 µS/cm to 150 mS/cm Accuracy: ± 2 % of measuring value ± 0.4 µS/cm (dependent on ambient and process temperature being equal)
Temperature compensation of conductivity sensor	Accuracy ≤ 0.8 % of measuring value at temperature conditions (T ambient - T process) ≤ ± 20 °C (± 68 °F)
Protection	IP65
Cleanability	Cleaning with standard cleaning agents (alcoholic surface disinfectants, quaternary ammonium compounds) is permitted. Caution! Ensure that windows are clean and dry and the contact unit for the electrodes is dry before starting measurement.
Technical Data	Single Use Cell (S.U.C.)
Material (wetted)	Windows (SUC 05, SUC 07): Quartz, UV transparent Gasket: EPDM (FDA, USP class VI) Conductivity electrode pins: stainless steel 1.4435 (SS 316L), dF < 1%, BN2 Sensor body: Polyphenylsulfone (PPSU) The plastic and elastomeric wetted parts of the sensor have passed the bio-reactivity tests according to USP <87> and <88> class VI and comply with FDA Regulations 21 CFR 177.2600. All wetted parts are of non-animal origin and any materials of animal origin or containing animal substances are not used during manufacture. All wetted parts are of bovine-free origin and any materials of bovine origin or containing TSE have not been used during manufacture.
Material (non wetted)	Adhesive: Epoxy LOCTITE M-31CL
Surface (wetted parts)	Ra < 0.8 µm
Process connection	Hose barb
Line Size	1/4 in., 3/8 in., 1/2 in., 5/8 in., 3/4 in., 1 in.
OPL (SUC 05, SUC 07)	1 mm, 2.5 mm, 10 mm, ... others on request
Shelf life	36 months after manufacturing date with adequate storage climatic conditions
Permitted gamma irradiation	typical 25 - 40 kGy (tested to 50 kGy)
Temperature and Pressure Ratings	
Process pressure	0 - 6 bar (0 - 87 psi) May be reduced in combination with pH probe. Refer to corresponding instruction manual for specifications of pH probe.
Process temperature	2 - 50 °C (35.6 - 122 °F) May be reduced in combination with pH probe. Refer to corresponding instruction manual for specifications of pH probe.
Ambient conditions	Temperature during operation: 2 - 30 °C (35.6 - 86 °F) Relative humidity 80 % for temperature up to 31 °C (87 °F)

Data given are subject to changes without prior notice.

Available Models					
S.U.C. Types	Conductivity	pH	UV	Hold-up Volume	Example
SUC 01	✓	—	—	20 ml	
SUC 03	✓	✓	—	20 ml	
SUC 05	✓	—	✓	(OPL 1 mm): 22 ml (OPL 2.5 mm): 23 ml (OPL 10 mm): 25 ml	
SUC 07	✓	✓	✓	(OPL 1 mm): 22 ml (OPL 2.5 mm): 23 ml (OPL 10 mm): 25 ml	

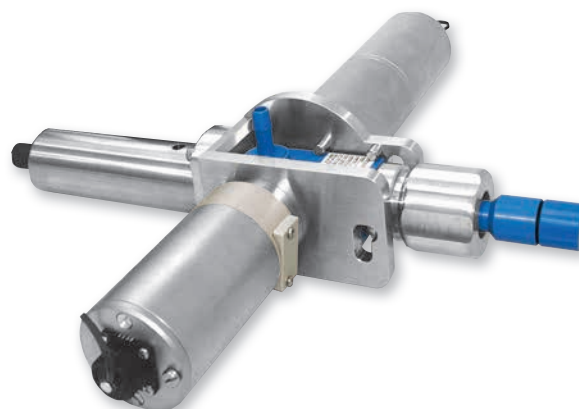

Fully assembled SUC 07 for measuring conductivity, pH, UV and temperature

26 | Sensor Body (Armature)

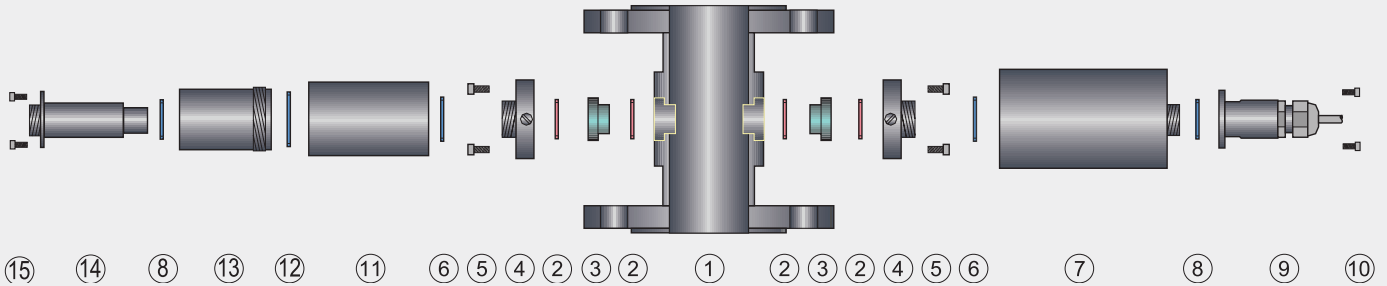

Example Exploded View - Model AF26:

- 1 Sensor body 1/8 in. to 6 in. (DN 6 to DN 150)
- 2 O-rings (EPDM, Viton®, Kalrez® etc.)
- 3 Windows (Sapphire, Pyrex®)
- 4 Window ring M24 (1.4571 / 316 Ti)
- 5 8 Screws (M5 x 12) with lock washer
- 6 O-ring (Viton®)
- 7 Detector module AF26
- 8 O-ring (EPDM, Viton®, Kalrez® etc.)
- 9 SS-plug protection (1.4571 / 316 Ti)
- 10 4 Screws (M3 x 6)
- 11 Optics module AF26
- 12 O-ring 31,47 x 1,78 mm
- 13 Optical housing OP06 (1.4571 / 316 Ti)
- 14 Lamp module AF26
- 15 4 Screws (M3 x 6)



Sensor Body	
For Variations and Details see Separate Sensor Body Datasheet	
Material	Stainless steel 1.4435 (SS 316L), 1.4539, 1.4571 (SS 316Ti), 1.4462, Titanium 3.7035 (Grade 2), Hastelloy 2.4602 (C22), Plastic TFM4215, PVC, ... others on request
Line size	1/8 in. to 6 in. (DN 6 to DN 150), ... others on request
Process connection	Flanges (ASME, DIN, JIS), Clamps (TC, ISO, DIN), Female Threads (NPT, DIN), Sanitary Threads (DIN 11851), Tube Ends (DIN, ISO, OD), Varivent, ... others on request
Process pressure	10 mbar to 100 bar (0.15 psi to 1450 psi) - higher on request depending on process connection, materials and design
Windows	1-Pyrex®, 2-Sapphire, 3-Sapphire Biotech
Window gaskets	Silicone (FDA), Viton® (FDA), EPDM (FDA / USP Class VI), Kalrez® 4079, ... others on request



Windows available in different lengths for OPL (optical path length) adjustment



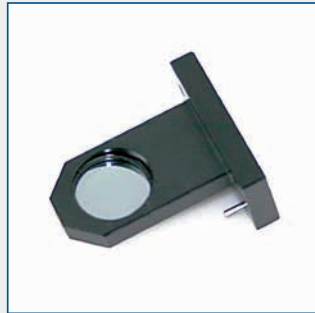

optek calibration accessories are specifically designed for nonintrusive calibration and verification of optek systems.

UV Sensors

Three series of solid filters are available to ensure confidence in measurements. The UV-L filter series is used to calibrate photometric accuracy and linearity. The UV-B filter series verifies integral blocking and the UV-S filter series tests for long-term stability of the sensor.

VIS/NIR Sensors

A special series of solid filters is available for each wavelength (range) to ensure best measurement performance. The calibration filters are used to calibrate photometric accuracy and linearity.

NIST-Traceable

All optek UV/VIS filters ship with NIST-traceable (National Institute of Standards and Technology) certification. The optek laboratory is equipped with a high quality, NIST-traceable spectrophotometer to assure quality and quick turnaround time for recertification of filters.

Concept

Advantages of optek calibration concept include:

- Only 1 filter (set) for multiple sensors ensures identical calibration
- Only the filter needs to be sent back for recertification, while the sensor remains operating

- **Calibration Filters UV-L**

Nominal absorption: 0.45, 0.9, 1.8 and 2.4 CU*

- **Calibration Filter UV-B**

Nominal absorption: > 3 CU*

- **Calibration Filters UV-S**

Nominal absorption: Application specific

- **Calibration Filters VIS-L**

Nominal absorption: 0.45, 0.9 and 1.8 CU*

- **Calibration Filters NIR-L**

Nominal absorption: 0.45, 0.9 and 1.8 CU*

*CU = Calibration Units

- **Calibration Case**

Holds up to 7 calibration filters

- **Calibration Cuvette**

The unique calibration cuvette, FH03, enables product calibration without need to interfere with the process line.

The cuvette allows users to create a correlation of absorption signals to the concentration of product or an equivalent substance, creating an easy link from lab to process.



Calibration cuvette FH03





Germany

optek-Danulat GmbH
Emscherbruchallee 2
45356 Essen / Germany
Phone: +49 201 63409 0
E-Mail: info@optek.de



USA

optek-Danulat Inc.
N118 W18748 Bunsen Drive
Germantown WI 53022 / USA
Phone: +1 262 437 3600
Toll free call: +1 800 371 4288
Fax: +1 262 437 3699
E-Mail: info@optek.com



Singapore

optek-Danulat Pte. Ltd.
25 Int'l Business Park
#02-09 German Centre
Singapore 609916
Phone: +65 6562 8292
Fax: +65 6562 8293
E-Mail: info@optek.com.sg



China

optek-Danulat Shanghai Co., Ltd.
Room 718 Building 1
No.88 Keyuan Road
Pudong Zhangjiang
Shanghai, China 201203
Phone: +86 21 2898 6326
Fax: +86 21 2898 6325
E-Mail: info@optek-danulat.com.cn

中国

优培德在线测量设备（上海）
有限公司
上海张江科苑路88
号德国中心718
室 邮编:201203
电话:+86-21-28986326
传真:+86-21-28986325
E-Mail: info@optek-danulat.com.cn

Optek, Минск +375 29 447 504 provider email minsk17@iut.by

Please visit our website for contact details of our local distributors in other countries.
www.optek.com

Industrial Sensing and Control

Product Selection Guide

OPTEK Technology BI Technologies Roxspur Measurement & Control

Оптек, Минск +375447584780 viber email minsk17@tut.by



About TT Electronics

About Industrial Sensing and Control

Measurement Solutions

Markets We Serve

Products

Optoelectronics

- Discretes
- Assemblies
- Hybrids
- Surface Mount and Chip Carrier
- High-Reliability
- Fiber Optics
- VLEDs

Steering Torque and Position Sensors

- Steering Sensors
- Rotary Encoders
- Rotary Panel Potentiometers
- Rotary Single and Multi-Turn Precision Potentiometers
- Precision Potentiometers
- Slide Potentiometers
- Rotary Single and Multi-Turn Non-Contacting Hall Effect Position Sensors
- Linear Potentiometers
- Single and Multi-Turn Cermet Trimmers

Test and Measurement

- Level Sensing Products
- OEM Pressure Sensors
- Pressure Transducers and Transmitters
- Flush Mounting & Abrasive Media
- Submersible Transducers and Transmitters
- Flowmeters
- Temperature Instrumentation
- Calibration Services

Optek, Минск +375447584780 viber email minsk17@tut.by

Model Numbers and specifications contained within this brochure were verified by technical personnel at the time of printing and should be used for reference purposes only. These reference Model Numbers are not intended to be used for systems design or sensor sizing. In the interests of continuous product improvement, TT Electronics' product specifications are subject to change without notice. For assistance with sensor selection, please contact a TT Electronics applications engineer, or your nearest authorized sales representative. All products shown are RoHS compliant unless otherwise noted.

WARRANTY: Seller warrants that the Products sold to Buyer hereunder will be free from defects in material and workmanship furnished by Seller and will conform, within normal commercial tolerances, to applicable Model #. This warranty shall apply only when Buyer has given Seller written notice of such defect on nonconformity within ninety (90) days after delivery of the Products by Seller and the warranty does not extend to any Product which has been subjected to abuse, misuse, neglect or accident, nor to any Product which has been repaired or altered by other than Seller. THE FOREGOING WARRANTY IS EXCLUSIVE AND IN LIEU OF ALL OTHER WARRANTIES, EXPRESSED OR IMPLIED, AS TO MERCHANT ABILITY, FITNESS FOR A PARTICULAR PURPOSE, DESCRIPTION, QUALITY, PRODUCTIVENESS, OR OTHERWISE.

About TT Electronics

TT Electronics is a global provider of engineered electronics for performance critical applications.

We harness our leading expertise to engineer electronics that put our customers ahead.



Optek, Минск +375447584780 viber email: info@ttel.by

TT Electronics has years of experience and expertise in engineering and delivering electronics for applications in the harshest environments across industrial, transportation, aerospace, defence and medical markets.

We work hard to develop strong long-term relationships with our customers, many of which are global leaders, working on cutting-edge innovation in some of the fastest growing markets in the global economy. We are proud to be able to say that our customers regularly seek us out as technology partners because they value us most for our:

- Expertise to provide electronics products and solutions that perform to the highest standards
- Personalised and responsive service, which because of our global presence we can deliver wherever they are in the world.

We love the challenges that our customers bring us and we work hard to develop solutions that work best for them.

Industrial Sensing and Control

- Formed in January 2015, the TT Electronics Industrial Sensing and Control division is an amalgamation of our BI Technologies, OPTEK Technology, and Roxspur Measurement & Control brands.
- We provide reliable standard and custom sensing solutions for industrial, aerospace and defence, oil and gas, process manufacturing, medical equipment, and off-road transportation sectors.
- We offer a diverse product portfolio, comprised of multiple core sensing technologies which address a broad range of measurement requirements, including position, temperature, pressure, flow, level and fluid quality, as well as calibration services.
- We have the full in-house capabilities to offer custom solutions with competitive lead times.
- We have earned a strong industry reputation as a trusted partner for industry leading OEMs, often times providing complex custom solutions for the most challenging applications.
- We have a dedicated global sales and engineering team that is entirely focused on delivering sustainable growth for TT Electronics and its customers.
- We seek to become a valued strategic partner to our end customers, helping them to anticipate present and future market needs.
- We offer field-proven, high-reliability designs that are rarely made obsolete, allowing our customers to warranty and service their own finished product designs with confidence.

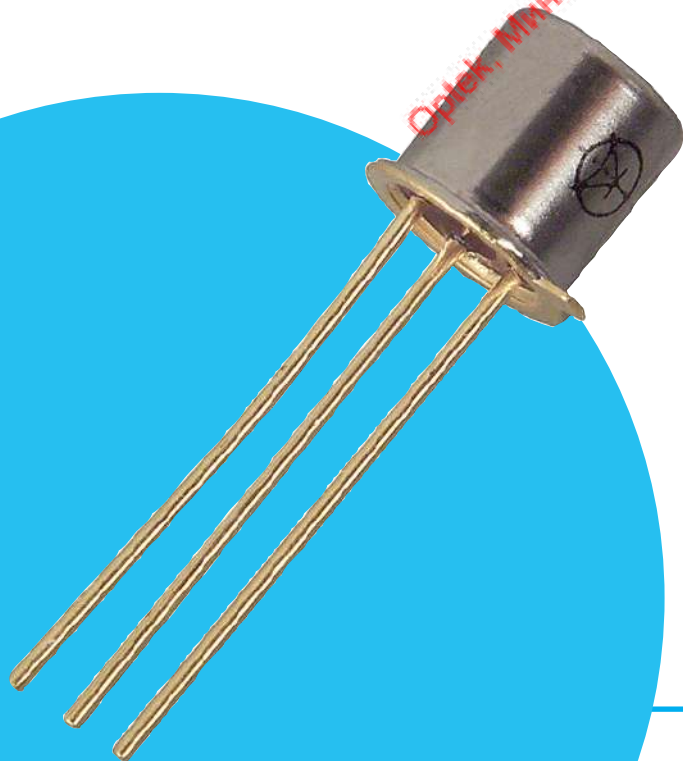

TT
E
O
P
A

Measurement Solutions

Position and Torque



- Contact and non-contacting position and torque sensors; fibre optics; magnetics; optocouplers, rotary encoders
- Optical encoder switches; infrared emitting diodes; photodiodes; LED/sensor pairs; transmissive switches

Pressure



- Ceramic sensors and submersible transducers; pressure transmitters; flush mount pressure transducers; abrasive media sensors

Flow



- Glass and plastic VA; metal VA and ultrasonic flowmeters; control valves; sensor transmitters; dataloggers and controllers

Temperature



- Thermocouples, refractory sheaths and cables, transmitters; thermal imaging; infrared thermometers; multi-spot thermometers; averaging thermometers

Calibration Services



- Onsite or in-house UKAS accredited calibration and certification under BS/EN ISO17025 accredited procedures

Markets we serve

Continuous investments in R&D and the very latest in manufacturing equipment ensure that TT Electronics' industrial sensing and control products keep pace with evolving customer needs.

Oil and Gas



- Exploration
- Distribution
- Refining

Continuous Process



- Continuous flow manufacturing of chemicals, synthetic fibres, papers, metals and glass

Utilities



- Power generation, transmission and distribution
- Water and wastewater treatment
- Irrigation systems

Aerospace and Defence



- Aircraft and satellite
- Defence electronics
- Unmanned aerial vehicles
- Cockpit controls

Discrete Manufacturing



- Production of factory automation machinery and supporting equipment for pumping, heating, fluid handling, and refrigeration

Medical Equipment



- Medical diagnostics
- Portable patient care equipment
- Drug therapy dispensers
- Blood analysers

Offroad Vehicles



- Materials handling
- Agricultural
- Construction
- Recreational (ATVs)

Industrial Printing



- High-end industrial printing on paper and plastic
- 3D printing

Banking and Security



- Automated teller machines
- Safety equipment
- Identification equipment

Discretes

The vast portfolio of discrete components offered by TT Electronics includes a full line of infrared emitting diodes, in a choice of either hermetic or plastic, reflective object sensors, silicon phototransistors and Photodarlington, optically coupled isolators, high-voltage isolators, slotted optical switches, and hallogic hall effect sensors.

Hermetic Infrared Emitting Diodes



Model Number	OP132	OP133W	OP232	OP232W	OP233	OP233W	OP234W
Package	TO-46 Dome Lens	TO-46 Flat Window	TO-46 Dome Lens	TO-46 Flat Window	TO-46 Dome Lens	TO-46 Flat Window	TO-46 Flat Window
LED Wavelength (nm)	935	935	890	890	890	890	890
Output Power (mW/cm ²) Min/Max	4.0/N/A	5.0/N/A	2.0/6.0	3.5/7.0	3.0/N/A	5.0/N/A	5.0/N/A
I _f (mA) Typ/Max	50/100	20/100	50/100	20/100	50/100	20/100	20/100
Beam Angle (Degrees)	18	50	18	50	18	50	50
Lead Length	0.5"	0.5"	0.50"	0.50"	0.50"	0.50"	0.50"

Hermetic Infrared Emitting Diodes



Model Number	OP224
Package	Dome Lens
LED Wavelength (nm)	890
Input Radiance E _e (mW/cm ²)	3.5
I _f (mA) Typ/Max	50/100
Viewing Angle (Degrees)	24

Plastic Infrared Emitting Diodes



Model Number	OP140A	OP166A	OP240A	OP240B	OP245A	OP245B
Package	Sidelooker 0.060" Base	T-1 0.100" Lead Spacing	Sidelooker 0.060" Base	Sidelooker 0.060" Base	Sidelooker 0.100" Base	Sidelooker 0.100" Base
LED Wavelength (nm)	935	935	890	890	890	890
Output Power (mW/cm ²) Min/Max	0.40/N/A	1.95/N/A	0.60/N/A	0.40/1.20	0.60/N/A	0.40/1.20
I _f (mA) Typ/Max	20/50	20/50	20/50	20/50	20/50	20/50
Beam Angle (Degrees)	40	18	40	40	40	40
Lead Length	0.50"	0.50"	0.50"	0.50"	0.50"	0.50"

Plastic Infrared Emitting Diodes



Model Number	OP265FAB	OP266W	OP291A	OP295A	OP298A
Package	T-1	T-1 Flat 0.100" Lead Spacing	T-1 3/4	T-1 3/4	Plastic TO-18
LED Wavelength (nm)	850	890	890	890	890
Output Power (mW/cm ²) Min/Max	7.5/12.5	1.00/N/A	16.0/N/A	44.0/N/A	3.0/N/A
I _F (mA) Typ/Max	20/50	20/50	50/100	100/1,500 Pulsed	50/100
Beam Angle (Degrees)	18	90	50	50	60
Lead Length	0.50"	0.50"	0.69"	0.69"	0.50"

Reflective Object Sensors



Model Number	OPB608A	OPB608B	OPB608V	OPB710F	OPB730	OPB730F
Package	Mini-Cube Reflective	Mini-Cube Reflective	Mini-Cube Reflective	O-46 Reflective	TO-46 Reflective	TO-46 Reflective
Wavelength (nm) (Typ)	890	890	850	935	935	935
Sensor Type	Rbe Transistor	Rbe Transistor	Rbe Transistor	Transistor	Darlington	Darlington
Reflection Distance Inch (mm)	0.050" (1.27 mm)	0.050" (1.27 mm)	0.050" (1.27 mm)	0.250" (6.35 mm)	0.250" (6.35 mm)	0.250" (6.35 mm)
I _{C(ON)} (mA) Min	2	1	5	0.15	1.00	1
I _F (mA) Typ/Max	20/50	20/50	7/12	20/50	20/50	20/50
V _{CE} (V) Typ/Max	30	30	30	30	15	15
Lead Length/Spacing	0.18"/0.24"	0.18"/0.24"	0.18"/0.24"	0.50"	0.50" DIA	0.50" DIA

Infrared Selected NPN Silicon Phototransistors



Model Number	OP505A	OP506A	OP506B	OP550A
Package	T-1	T-1	T-1	Sidelooker
Light Current I _{C(ON)} (mA) Min/Max	4.30/N/A	4.30/N/A	2.15/5.95	2.55/N/A
V _{CE} (V) Max	30	30	30	30
Input Power E _E (mW/cm ²)	1.00	1.00	1.00	1.00
Viewing Angle (Degrees)	25	25	25	60
Lead Length/Spacing	0.5"/0.050"	0.5"/0.100"	0.5"/0.100"	0.5"/0.100"

NPN Plastic Silicon Phototransistors



Model Number	OP593A
Package	Plastic TO-18
Light Current I _{C(ON)} (mA) Min/Max	3.00/N/A
V _{CE} (V) Max	30
Input Power E _E (mW/cm ²)	1.70
Viewing Angle (Degrees)	130
Lead Length	0.75"

NPN Silicon Phototransistors



Model Number	OP800A	OP802WSL	OP803SL	OP805SL
Package	TO-18/46 Dome Lens	TO-46 Flat Window	TO-18/46 Dome Lens	TO-18/46 Dome Lens
Light Current $I_{C(ON)}$ (mA) Min/Max	3.60/N/A	2.5/N/A	4.00/8.00	15.00/N/A
V_{CE} (V) Max	30	30	30	30
Input Power E_E (mW/cm ²)	0.5	5.00	5.00	5.00
Viewing Angle (Degrees)	25	75	25	25
Lead Length	0.5"	0.5"	0.50"	0.50"

NPN Silicon Photodarlington

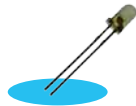

Model Number	OP535B
Package	T-1 0.050" Lead Spacing
Light Current $I_{C(ON)}$ (mA) Min/Max	3.5/32.0
V_{CE} (V) (Max)	2.0/15.0
Input Power E_E (mW/cm ²)	0.13
Viewing Angle (Degrees)	25
Lead Length	0.5"

Optically Coupled Isolators



Model Number	OPI120
Package	Axial Channel
LED Wavelength (nm)	890
Sensor Type	Transistor
CTR (Min/Max)	20
Isolation Voltage	15 kV
I_F (mA) Typ/Max	10/50
V_{CE} (V) (Max)	25
Lead Length/Spacing	0.40"/0.75"

Optically Coupled Isolators

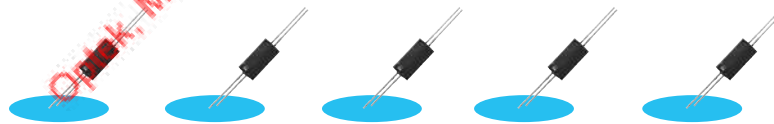

Model Number	OPI110C	OPI1150	OPI1264A	OPI1264B	OPI1264C
Package	Axial-Cylindrical	Axial-Cylindrical	Axial-Cylindrical	Axial-Cylindrical	Axial-Cylindrical
Wavelength (nm) (Typ)	890	890	890	890	890
Sensor Type	Transistor	Transistor	Transistor	Transistor	Transistor
CTR (Min/Max)	100/N/A	10	25/N/A	50/125	100/N/A
Isolation Voltage	10 kV	50 kV	10 kV	10 kV	10 kV
I_F (mA) Typ/Max	10/40	16/50	10/40	10/40	10/40
V_{CE} (V) (Max)	30	5/30	30	30	30
Lead Length/Spacing	0.50"/0.55"	0.40"/3.16"	0.50"/0.55"	0.50"/0.55"	0.50"/0.55"

Photologic® Sensor



Model Number	OPL530	OPL550
Package	Sidelooker 0.060" Base	Sidelooker 0.060" Base
Photologic	10K Pull-Up	Totem-Pole
Input Power E_e (mW/cm ²) Min/Max	0.12/0.38	0.25/2.4
V_{CC} (V) (Min/Max)	4.5/16.0	4.5/5.5
Lead Length/Spacing	0.50"/0.075"	0.50"/0.075"

Photodiode Sensor

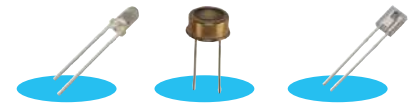

Model Number	OP906	OP913WSL	OP950
Package	T-1	TO-5	Sidelooker 0.060" Base
Light Current I_c Min/Max (μA)	16.0/35.0	40.0/N/A	8.0/18.0
V_R (V) (Max)	60	32	60
Input Power E_e (mW/cm ²)	0.5	5.0	1.00
Viewing Angle (Degrees)	95	80	95
Lead Length/Spacing	0.50"/0.100"	0.50"/0.200"	0.50"/0.100"

Slotted Optical Switch



Model Number	OPB610	OPB620
Package	Slotted N	Slotted N
Wavelength (nm) (Typ)	890	890
Slot Width/Depth	0.150"/0.240"	0.190"/0.285"
Aperture Emitter/Sensor	0.06"/0.06"	0.06"/0.06"
I_f (mA) Typ/Max	20/50	20/50
Light Current $I_{C(ON)}$ (mA) Min/Max	1.0 /N/A	1.0 /N/A
V_{CE} (V) (Max)	24	24
Lead Length/Spacing	0.100"/0.275"	0.100"/0.320"

Photologic® Slotted Optical Switch

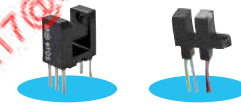

Model Number	OPB625	OPB627
Package	Slotted N	Slotted N
Sensor Type	10K Pull-up	Inv-10K
Gap Width/Depth	0.190"/0.285"	0.190"/0.285"
Aperture Emitter/Sensor	0.06"/0.06"	0.06"/0.06"
Wavelength (nm) (Typ)	890	890
I_f (mA) Typ/Max	20/50	20/50
I_{CCL}/I_{CCH} (mA) Max	12/12	12/12
V_{CC} (V) (Max)	4.5/16.0	4.5/16.0
Lead Length/Spacing	0.100"/0.320"	0.100"/0.320"

High-Voltage Isolators



Model Number	OPI1266	OPI1268
Package	Side Channel	Side Channel
LED Wavelength (nm)	890	890
Sensor Type	Open Collector	Open Collector
Isolation Voltage	16 kV	16 kV
CTR (Min/Max)	Logic 15 mA	Logic 15 mA
tPLH/tPHL Typ (ns)	800/800	100/200
I_f (mA) Typ/Max	13.5/50	10/50
V_{CE} (V) (Max)	7	18
Lead Length/Spacing	0.12"/0.98"	0.40"/0.75"

Hallogic Hall Effect Sensors



Model Number	OH090U
Package	Side Sensing TO-92
Output Type	Uni-Polar Non-Latching
Operating Point Gauss (Min/Typ/Max)	0/90/180
Release Point Gauss (Min/Typ/Max)	-100/65/100
Hysteresis Gauss (Min/Typ/Max)	10/25/100
V_{CC} (Volts) Min/Max	4.5/24.0

Assemblies

TT Electronics' standard assemblies provide space saving solutions of up to 80%, as compared to discrete packaged parts. A full range of available products includes tube liquid sensors, optical slotted switches, reflective object sensors, optical emitters and sensor pairs, dual encoders, and long distance reflective and optical switches. TT Electronics can provide complete design and manufacturing services of all assemblies. This includes final assembly and 100% testing, as well as standard chip carrier and custom packaging options. Product ranges include an extensive range of unique shapes, mounting configurations and material combinations.

Tube Liquid Sensor

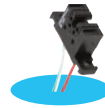
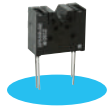
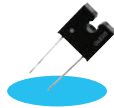

Model Number	OPB350	OPB350L062	OPB350W062Z	OPB350W125Z	OPB350W250Z
Package	Slotted N	Slotted N	Slotted T	Slotted T	Slotted T
LED Peak Wavelength (nm)	890	890	890	890	890
Tube Size	0.125"	0.062" [1.57 mm]	0.062" [1.57 mm]	0.125" [3.18 mm]	0.250"
I _{C(ON)} Ratio Typ	01:03.0	01:03.0	01:03.0	2.5	01:02.3
I _F (mA) Typ/Max	5/50	5/50	5/50	5/50	5/50
V _{CE} (V) (Max)	30	30	30	24	30
Lead Length/Spacing	0.33"/0.32"	0.33"/0.32"	24"/26 AWG Wire	24"/26 AWG Wire	24"/26 AWG Wire

Slotted Optical Switches



Model Number	OPB200	OPB365T55	OPB380P55Z	OPB380T51Z	OPB390L11Z	OPB390P11Z	OPB390T51Z
Package	Slotted L	Slotted T	Slotted P	Slotted T	Slotted L	Slotted P	Slotted T
Wavelength (nm) (Typ)	890	890	890	890	890	890	890
Slot Width/Depth	0.200"/0.320"	0.125"/0.345"	0.125"/0.345"	0.125"/0.345"	0.125"/0.345"	0.125"/0.345"	0.125"/0.345"
Aperture Emitter/Sensor	0.06"/0.06"	0.05"/0.05"	0.05"/0.05"	0.05"/0.01"	0.01"/0.01"	0.01"/0.01"	0.05"/0.01"
I _F (mA) Typ/Max	20/50	20/50	20/50	20/50	20/50	20/50	20/50
Light Current I _{C(ON)} (mA) Min/Max	1.0/6.0	3.5/14.0	1.0/5.0	2.5/10.0	1.0/5.0	1.0/5.0	2.5/10.0
V _{CE} (V) (Max)	30	30	30	30	30	30	30
Lead Length/Spacing	0.425"/0.400"	0.425"/0.320"	24"/26 AWG Wire	24"/26 AWG Wire	24"/26 AWG Wire	24"/26 AWG Wire	24"/26 AWG Wire

Slotted Optical Switches (Continued)



Model Number	OPB390T55Z	OPB804	OPB816Z	OPB818	OPB820S10	OPB821S5Z	OPB825
Package	Slotted T	Slotted N	Slotted T	Slotted N	Slotted P	Slotted P	Slotted N
Wavelength (nm) (Typ)	890	935	890	890	890	890	890
Slot Width/Depth	0.125"/0.345"	0.150"/0.330"	0.200" / 0.635"	0.200"/0.250"	0.125"/0.345"	0.080"/0.255"	0.160"/0.285"
Aperture Emitter/Sensor	0.05"/0.05"	0.06"/0.06"	0.05"/0.01"	0.06"/0.06"	0.04"/0.01"	0.04"/0.005"	0.06"/0.06"
I _F (mA) Typ/Max	20/50	20/30	20/50	20/30	20/50	20/50	20/30
Light Current I _{C(ON)} (mA) Min/Max	3.5/14.0	0.5/N/A	N/A/30	0.1/N/A	0.50/N/A	0.30 /N/A	0.5/N/A
V _{CE} (V) (Max)	30	30	30	30	30	30	30
Lead Length/Spacing	24"/26 AWG Wire	0.425"/0.300"	24"/26 AWG Wire	0.425"/0.400"	0.425"/0.275"	24"/26 AWG Wire	0.200"/0.300"



Model Number	OPB828D	OPB829CZ	OPB829DZ	OPB830W11Z	OPB830W55Z	OPB831W55Z	OPB832W55Z
Package	Slotted T	Slotted T	Slotted T	Slotted T	Slotted T	Slotted T	Slotted T
Wavelength (nm) (Typ)	890	890	890	880	880	890	880
Slot Width/Depth	0.120"/0.315"	0.125"/0.315"	0.125"/0.315"	0.125"/0.315"	0.125"/0.315"	0.125"/0.315"	0.125"/0.315"
Aperture Emitter/Sensor	0.06"/0.01"	0.06"/0.06"	0.06"/0.01"	0.01"/0.01"	0.05"/0.05"	0.05"/0.05"	0.05"/0.05"
I _F (mA) Typ/Max	20/50	20/50	20/50	20/50	20/50	20/50	20/50
Light Current I _{C(ON)} (mA) Min/Max	1.8/N/A	1.8/N/A	1.8/N/A	0.625/N/A	0.625/N/A	1.25/N/A	2.25/N/A
V _{CE} (V) (Max)	30	30	30	30	30	30	30
Lead Length/Spacing	0.425"/0.220"	24"/26 AWG Wire	24"/26 AWG Wire	24"/26 AWG Wire	24"/26 AWG Wire	24"/26 AWG Wire	24"/26 AWG Wire



Model Number	OPB840L11	OPB840W11Z	OPB840W51Z	OPB840W55Z	OPB842W51Z	OPB857Z	OPB870N11
Package	Slotted T	Slotted T	Slotted T	Slotted T	Slotted T	Slotted Channel	Slotted N
Wavelength (nm) (Typ)	890	880	880	880	880	890	890
Slot Width/Depth	0.125"/0.315"	0.125"/0.315"	0.125"/0.315"	0.125"/0.315"	0.125"/0.315"	0.150"/0.355"	0.125"/0.345"
Aperture Emitter/Sensor	0.05"/0.01"	0.01"/0.01"	0.05"/0.01"	0.05"/0.05"	0.05"/0.01"	0.06"/0.06"	0.01"/0.01"
I _F (mA) Typ/Max	20/50	20/50	20/50	20/50	20/50	20/50	20/50
Light Current I _{C(ON)} (mA) Min/Max	0.625/N/A	0.625/N/A	0.625/N/A	0.625/N/A	2.25/N/A	1.5/N/A	0.5/N/A
V _{CE} (V) (Max)	30	30	30	30	30	30	30
Lead Length/Spacing	0.425"/0.320"	24"/26 AWG Wire	24"/26 AWG Wire	24"/26 AWG Wire	24"/26 AWG Wire	11.5"/26 AWG Wire	0.425"/0.320"

Slotted Optical Switches (Continued)



Model Number	OPB871N51	OPB880P51Z	OPB880T51Z	OPB885Z	OPB890P51Z	OPB891T51Z
Package	Slotted N	Slotted P	Slotted T	Slotted P	Slotted P	Slotted T
Wavelength (nm) (Typ)	890	890	890	890	890	890
Slot Width/Depth	0.125"/0.345"	0.125"/0.345"	0.125"/0.315"	0.375"/0.595"	0.125"/0.345"	0.125"/0.315"
Aperture Emitter/Sensor	0.05"/0.01"	0.05"/0.01"	0.05"/0.01"	0.05"/0.05"	0.05"/0.01"	0.05"/0.01"
I _f (mA) Typ/Max	20/50	20/50	20/50	20/50	20/50	20/50
Light Current I _{CC(ON)} (mA) Min/Max	1.0/N/A	0.5/N/A	0.5/N/A	1.3/8.0	0.5/N/A	1.0/N/A
V _{CE} (V) (Max)	30	30	30	30	30	50
Lead Length/Spacing	0.425"/0.320"	24"/26 AWG Wire	24"/26 AWG Wire	24"/26 AWG Wire	24"/26 AWG Wire	24"/26 AWG Wire

Wide Gap Slotted Optical Switches



Model Number	OPB800L55	OPB800W51Z	OPB810L51	OPB810W51Z	OPB811L55	OPB811W55Z
Package	Slotted T	Slotted T	Slotted T	Slotted T	Slotted T	Slotted T
Wavelength (nm) (Typ)	890	890	890	890	890	890
Slot Width/Depth	0.375"/0.350"	0.375"/0.350"	0.375"/0.350"	0.375"/0.350"	0.375"/0.350"	0.375"/0.350"
Aperture Emitter/Sensor	0.05"/0.05"	0.05"/0.01"	0.05"/0.01"	0.05"/0.01"	0.05"/0.05"	0.05"/0.05"
I _f (mA) Typ/Max	20/50	20/50	20/50	20/50	20/50	20/50
Light Current I _{CC(ON)} (mA) Min/Max	0.05/N/A	0.05/N/A	0.05/N/A	0.05/N/A	1.0/N/A	1.0/N/A
V _{CE} (V) (Max)	30	30	30	30	30	30
Lead Length/Spacing	0.425"/0.570"	24"/26 AWG Wire	0.425"/0.570"	24"/26 AWG Wire	0.425"/0.570"	24"/26 AWG Wire

Photologic® Slotted Optical Switches



Model Number	OPB930W51Z	OPB930W55Z	OPB933W51Z	OPB940W51Z	OPB941W51Z	OPB943W51Z	OPB961N51	OPB961T51	OPB970N11
Package	Slotted T	Slotted T	Slotted T	Slotted T	Slotted T	Slotted T	Slotted N	Slotted T	Slotted N
Sensor Type	Totem-Pole	Totem-Pole	Inv-Open-Collector	Totem-Pole	Open-Collector	Inv-Open-Collector	Open-Collector	Open-Collector	Totem-Pole
Wavelength (nm) (Typ)	0.125"/0.315"	0.125"/0.315"	0.125"/0.315"	0.125"/0.315"	0.125"/0.315"	0.125"/0.315"	0.125"/0.345"	0.125"/0.345"	0.125"/0.345"
Slot Width/Depth	0.05"/0.01"	0.05"/0.05"	0.05"/0.01"	0.05"/0.01"	0.05"/0.01"	0.05"/0.01"	0.05"/0.01"	0.05"/0.01"	0.01"/0.01"
Aperture Emitter/Sensor	880	880	880	880	880	880	890	890	890
I _f (mA) Typ/Max	20/50	20/50	20/50	20/50	20/50	20/50	20/50	20/50	20/50
I _{CCL} /I _{CCH} (mA) Max	15/15	15/15	15/15	15/15	15/15	15/15	15/15	15/15	15/15
V _{CC} (V) Min/Max	4.75/5.25	4.75/5.25	4.75/5.25	4.75/5.25	4.75/5.25	4.75/5.25	4.5/16.0	4.5/16.0	4.5/16.0
Lead Length/Spacing	24"/26 AWG Wire	24"/26 AWG Wire	24"/26 AWG Wire	24"/26 AWG Wire	24"/26 AWG Wire	24"/26 AWG Wire	0.425"/0.320"	0.425"/0.320"	0.425"/0.320"

Photologic® Slotted Optical Switches



Model Number	OPB970N51	OPB971N51	OPB973N51	OPB980L51Z	OPB980L55Z	OPB980T55Z	OPB982P51Z	OPB983P51Z	OPB983T51Z
Package	Slotted N	Slotted N	Slotted N	Slotted L	Slotted L	Slotted T	Slotted P	Slotted P	Slotted T
Sensor Type	Totem-Pole	Open-Collector	Inv-Open-Collector	Totem-Pole	Totem-Pole	Totem-Pole	Inv-Totem-Pole	Inv-Open-Collector	Inv-Open-Collector
Wavelength (nm) (Typ)	0.125"/0.345"	0.125"/0.345"	0.125"/0.345"	0.125"/0.345"	0.125"/0.345"	0.125"/0.345"	0.125"/0.345"	0.125"/0.345"	0.125"/0.345"
Slot Width/Depth	0.05"/0.01"	0.05"/0.01"	0.05"/0.01"	0.05"/0.01"	0.05"/0.05"	0.05"/0.05"	0.05"/0.01"	0.05"/0.01"	0.05"/0.01"
Aperture Emitter/Sensor	890	890	890	890	890	890	890	890	890
I _F (mA) Typ/Max	20/50	20/50	20/50	20/50	20/50	20/50	20/50	20/50	20/50
I _{CC1} /I _{CC2} (mA) Max	15/15	15/15	15/15	15/15	15/15	15/15	15/15	15/15	15/15
V _{CC} (V) Min/Max	4.5/16.0	4.5/16.0	4.5/16.0	4.5/16.0	4.5/16.0	4.5/16.0	4.5/16.0	4.5/16.0	4.5/16.0
Lead Length/Spacing	0.425"/0.320"	0.425"/0.320"	0.425"/0.320"	24"/26 AWG Wire	24"/26 AWG Wire	24"/26 AWG Wire	24"/26 AWG Wire	24"/26 AWG Wire	24"/26 AWG Wire



Model Number	OPB990L51Z	OPB990P51Z	OPB990T51Z	OPB990T55Z	OPB991L51Z	OPB992T51Z	OPB993L11Z
Package	Slotted L	Slotted P	Slotted T	Slotted T	Slotted L	Slotted T	Slotted L
Sensor Type	Totem-Pole	Totem-Pole	Totem-Pole	Totem-Pole	Open-Collector	Inv-Totem-Pole	Inv-Open-Collector
Wavelength (nm) (Typ)	0.125"/0.345"	0.125"/0.315"	0.125"/0.345"	0.125"/0.345"	0.125"/0.345"	0.125"/0.345"	0.125"/0.345"
Slot Width/Depth	0.05"/0.01"	0.05"/0.01"	0.05"/0.01"	0.05"/0.05"	0.05"/0.01"	0.05"/0.01"	0.01"/0.01"
Aperture Emitter/Sensor	890	890	890	890	890	890	890
I _F (mA) Typ/Max	20/50	20/50	20/50	20/50	20/50	20/50	20/50
I _{CC1} /I _{CC2} (mA) Max	15/15	15/15	15/15	15/15	15/15	15/15	15/15
V _{CC} (V) Min/Max	4.5/16.0	4.5/16.0	4.5/16.0	4.5/16.0	4.5/16.0	4.5/16.0	4.5/16.0
Lead Length/Spacing	24"/26 AWG Wire	24"/26 AWG Wire	24"/26 AWG Wire	24"/26 AWG Wire	24"/26 AWG Wire	24"/26 AWG Wire	24"/26 AWG Wire

Photologic® Slotted Optical Switches

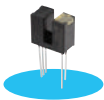

Model Number	OPB460N11
Package	Slotted N
Sensor Type	10K Pull-up
Gap Width/Depth	0.125"/0.345"
Aperture Emitter/Sensor	0.01"/0.01"
Wavelength (nm) (Typ)	890
I _F (mA) Typ/Max	20/50
I _{CC1} /I _{CC2} (mA) Max	7.5/7.5
V _{CC} (Volts) Min/Max	4.5/16.0
Lead Length/ Spacing	0.425"/0.320"

Deep Gap Slotted Switch Wire and Connector Options



Model Number	OPB815L	OPB815WZ
Package	Slotted T	Slotted T
Wavelength (nm) (Typ)	890	890
Slot Width/Depth	0.375"/0.350"	0.375"/0.430"
Aperture Emitter/Sensor	0.06"/0.06"	0.06"/0.06"
I _F (mA) Typ/Max	20/50	20/50
Light Current I _{C(ON)} (mA) Min/Max	0.05/N/A	1.0/N/A
V _{CE} (V) (Max)	30	30
Lead Length/Spacing	0.100"/0.530"	24"/26 AWG Wire

Optical Emitter and Sensor Pair



Model Number	OPB100Z	OPB100-EZ	OPB100-SZ
Package	Module Pair	1/2 Module Pair	1/2 Module Pair
LED Wavelength (nm)	880	880	-
Sensor Type	Phototransistor	-	Phototransistor
$I_{C(ON)}$ (mA) Min/Max	5.0	N/A	N/A
I_F (mA) Typ/Max	20/100	20/100	N/A
V_{CE} (V) (Max)	30	N/A	30
Lead Length/Spacing	24"/26 AWG Wire	-	24"/26 AWG Wire

Slotted Optical Flag Switch



Model Number	OPB680-20
Package	Flag Switch
Wavelength (nm) (Typ)	890
Sensor Type	Rbe Transistor
Flag Travel Degrees Max	51°
$I_{C(ON)}$ (mA) Min/Max	0.6
I_F (mA) Typ/Max	10/50
V_{CE} (V) (Max)	30
Lead Length/Spacing	0.100"/0.275"

Photologic® Slotted Optical Switch "Wide Gap" Series

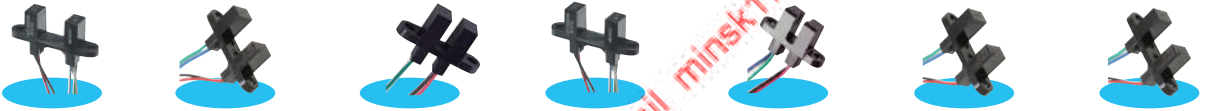

Model Number	OPB900W55Z	OPB901W55Z	OPB903W55Z	OPB910W55Z	OPB911W55Z	OPB912W55Z	OPB913W55Z
Package	Slotted T	Slotted T	Slotted T	Slotted T	Slotted T	Slotted T	Slotted T
Sensor Type	Totem-Pole	Open-Collector	Inv-Open-Collector	Totem-Pole	Open-Collector	Inv-Totem-Pole	Inv-Open-Collector
Gap Width/Depth	0.375"/0.350"	0.375"/0.350"	0.375"/0.350"	0.375"/0.350"	0.375"/0.350"	0.375"/0.350"	0.375"/0.350"
Aperture Emitter/Sensor	0.05"/0.05"	0.05"/0.05"	0.05"/0.05"	0.05"/0.05"	0.05"/0.05"	0.05"/0.05"	0.05"/0.05"
Wavelength (nm) (Typ)	890	890	890	890	890	890	890
I_F (mA) Typ/Max	20/50	20/50	20/50	20/50	20/50	20/50	20/50
I_{CCL}/I_{CCH} (mA) Max	15/15	15/15	15/15	15/15	15/15	15/15	15/15
V_{CC} (Volts) Min/Max	4.75/5.25	4.75/5.25	4.75/5.25	4.75/5.25	4.75/5.25	4.75/5.25	4.75/5.25
Lead Length/Spacing	24"/26 AWG Wire	24"/26 AWG Wire	24"/26 AWG Wire	24"/26 AWG Wire	24"/26 AWG Wire	24"/26 AWG Wire	24"/26 AWG Wire

Reflective Object Sensors



Model Number	OPB733TR	OPB745	OPB700ALZ	OPB701ALZ	OPB704	OPB704WZ	OPB706A	OPB711
Package	SMD Reflective Object	Reflective Switch	Reflective Switch	Reflective Switch	Reflective Switch	Reflective Switch	Cube Reflective	Flat Reflective
Sensor Type	Transistor	Darlington	Transistor	Darlington	Transistor	Transistor	Transistor	Transistor
Wavelength (nm) (Typ)	890	890	890	890	890	890	935	890
Reflection Distance Inch (mm)	0.4 (10.16 mm) to 1 (25.4 mm)	0.150" (3.81 mm)	0.200" (5.08 mm)	0.200" (5.08 mm)	0.150" (3.81 mm)	0.150" (3.81 mm)	0.050" (1.27 mm)	0.080" (2.03 mm)"
$I_{C(ON)}$ (mA) Min	0.1	0.1	0.1	2.5	0.2	0.2	0.5	0.35
I_F (mA) Typ/Max	20/50	40/40	40/100	40/50	40/40	40/40	20/50	20/50
V_{CE} (V) (Max)	30	15	24	15	30	30	24	24
Lead Length/Spacing	-	0.150"/N/A	18"/26 AWG Wire	18"/26 AWG Wire	0.160"/N/A	24"/26 AWG Wire	0.45"/0.087", 0.100"	0.30"/0.095", 0.100"

Dual Channel Encoder

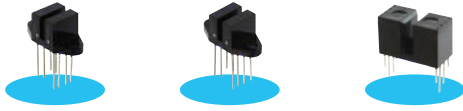

Model Number	OPB822S	OPB822SD	OPB826SD
Package	Dual Slotted	Dual Slotted	Dual Slotted
Wavelength (nm) (Typ)	935	935	890
Gap Width/Depth	0.090"/0.300"	0.090"/0.300"	0.100"/0.420"
$I_{C(ON)}$ (mA) Min	0.25	0.1	0.1
I_f (mA) Typ/Max	20/50	20/50	20/50
V_{CE} (V) Typ/Max	30	30	30
Aperture Emitter/Sensor	N/A/0.01"	0.01"/0.01"	0.04"/0.04"
Lead Length/Spacing	0.425"/0.300"	0.425"/0.300"	0.200"/0.740"

Photologic® Reflective Object Sensors

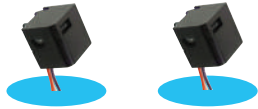

Model Number	OPB716Z	OPB718Z
Package	Object Reflective	Object Reflective
Sensor Type	Open-Collector	Inv-Open-Collector
Wavelength (nm) (Typ)	890	890
Reflection Distance Inch (mm)	0.50"	0.50"
I_{CC}/I_{CCH} (mA) Max	0.1/0.01	0.1/0.01
I_f (mA) Typ/Max	30/30	30/30
V_{CC} (V) (Min/Max)	4.75/5.25	4.75/5.25
Lead Length/Spacing	18"/26 AWG Wire	18"/26 AWG Wire

Long Distance Optical Switch



Model Number	OPB732WZ
Package	Object Reflective
Sensor Type	Transistor
Wavelength (nm) (Typ)	850
Reflection Distance Inch (mm)	3.0" (76.2 mm)
$I_{C(ON)}$ (mA) Min	0.25
V_{CE} (V) (Max)	30
Lead Length/Spacing	24"/26 AWG Wire

Long Distance Reflective Switch



Model Number	OPB720B-12Z	OPB720B-30VZ	OPB755TZ
Package	Objective Reflective	Objective Reflective	Reflective Switch
Sensor Type	Open-Collector	Open-Collector	Transistor & Rbe
Wavelength (nm) (Typ)	890	890	890
Reflection Distance Inch (mm)	12" [30.5 cm]	30" [76.2 cm]	0.08"/0.15"/0.22"
I_f (mA) Typ/Max	N/A	N/A	30/50
V_{CC} (V) or V_{CE} (V) (Min/Max)	4/7 V_{CC}	4/7 V_{CC}	N/A/24 V_{CE}
$I_{C(ON)}$ (mA) Min	N/A	N/A	0.500/0.375/0.250
V_{CE} (V) (Max)	30	30	30
Lead Length/Spacing	39" [99 cm]	39" [99 cm]	12"/26 AWG Wire

Hybrids

The hybrid components portfolio of TT Electronics can help to reduce costs, enhance reliability, and increase circuit performance. Our optoelectronic hybrid product designs combine opto sensors and LEDs with chip level components, to create systems that simplify motion and surface detection functions. Hybrid product technologies include visible and infrared LEDs, VCSELs, photodiode arrays, phototransistor arrays, reflective assemblies, and custom control components.

Miniature SMD Reflective Sensor



Model Number	OPR5005
Package	SMD Chip Carrier
Sensor Type	Transistor
Wavelength (nm) (Typ)	890
Reflection Distance Inch (mm)	0.05 to 0.20
$I_{C(ON)}$ (mA) Min	0.1
I_F (mA) Typ/Max	20/50
V_{CE} (V) (Max)	30
Lead Length/Spacing	SMD

Six-Element SMD Photodiode Array



Model Number	OPR2101
Package	Surface Mount
Receiver Type	Diode Array
# of Elements	6
Responsivity (mA/mW) Min	0.45
Reverse Voltage Min	50
Active Area mm ²	0.84

Miniature Surface Mount



Model Number	OPR5200
Package	1208 Flat Lens
LED Wavelength (nm)	890
Output Power Min (mW/cm ²)	0.35
V_F (V) Max	1.8
I_F (mA) Typ/Max	20/50
Beam Angle (Degrees)	90

Surface Mount Quad Photodiode



Model Number	OPR5925
Package	Quad
Receiver Type	Photodiode Array
# of Elements	4
Responsivity (mA/mW) Min	0.45
Reverse Voltage Min	35
Active Area mm ²	0.64 X 4

Infrared Light Emitting VCSEL



Model Number	OPR2800V
Package	Flat Lens Window
LED Wavelength (nm)	850
Output Power (mW/cm ²) Min/Max	1.5
I_F (mA) Typ/Max	7.0/12
Beam Angle (Degrees)	24
Lead Length	leadless

Oplek, Минск +375447584780 Web email minsk17@tul.by

Surface Mount and Chip Carrier

The TT Electronics surface mount and chip carrier portfolio includes SMD emitter components, infrared LEDs, vertical cavity surface emitting diodes, photodiodes, phototransistors, optical comparators, and optoisolators.

LEDs



Model Number	OP181	OPR2800T	OPR5200	OPV310Y	OPV314	OPV314Y
Package	SMD	SMD	1208 Flat Lens	TO-46 Flat Window	TO-46 Bead Lens	TO-46 Bead Lens
LED Wavelength (nm)	940	880	890	850	850	850
Output Power Min (mW/cm ²)	0.26	0.2	0.35	1.5	1.4	1.4
V _F (V) Max	1.65	1.5	1.8	2.2	2.2	2.2
I _F (mA) Typ/Max	20/50	20/50	20/50	7.0/12	7.0/12	7.0/12
Beam Angle (Degrees)	10°	100°	90°	24°	-	-

Photodiodes



Model Number	OP980	OPR2100	OPR2100HS	OPR2100HST	OPR2100T	OPR2101
Package	PLCC-2	Surface Mount	Surface Mount	Surface Mount	Surface Mount	Surface Mount
Receiver Type	Photodiode	Diode Array	Diode Array	Diode Array	Diode Array	Diode Array
# of Elements	1	6	6	6	6	6
Responsivity (mA/mW) Min	0.45	0.45	0.45	0.45	0.45	0.45
Reverse Voltage Min	60	50	50	50	50	50
Active Area mm ²	.175	3.45	3.45	3.45	3.45	0.84



Model Number	OPR5910	OPR5910T	OPR5911	OPR5913	OPR5915	OPR5925
Package	Single	Single	Quad	Single	Single	Quad
Receiver Type	Photodiode	Photodiode	Photodiode Array	Photodiode	Photodiode	Photodiode Array
# of Elements	1	1	4	1	1	4
Responsivity (mA/mW) Min	0.45	0.45	0.45	0.4	0.45	0.45
Reverse Voltage Min	35	35	14	10	35	35
Active Area mm ²	.316	.316	1.00 X 4	25	7.8	0.64 X 4

Phototransistors



Model Number	OP580DA	OPR5500
Package	PLCC-2	1208 Flat Lens
Light Current $I_{C(ON)}$ (mA) Min	10	0.036
V_{CE} (V) Max	35	30
Input Power EE (mW/cm ²)	0.15	0.15
Viewing Angle	100°	120°
Active Area mm ²	0.73	0.73

Optical Comparators



Model Number	OPR5011	OPR5011T
Package	Three Differential Comparators	Three Differential Comparators
Sensor Type	Differential Optical Comparator	Differential Optical Comparator
# of Elements	3	3
I_{CC} (mA) Typ/Max	9/20	9/20
Optical Hysteresis (%) Typ	40	40
Optical Offset (%) Min/Max	-40/+40	-40/+40

Optoisolator/Optocoupler



Model Number	4N22U 4N22UTX 4N22UTXV	4N23UTX 4N23UTXV	4N24U 4N24UTX 4N24UTXV	4N47U 4N47UTX 4N47UTXV	4N48U 4N48UTX 4N48UTXV	4N49U 4N49UTX 4N49UTXV	HCC240 HCC240TX HCC240TXV	HCC242 HCC242TX HCC242TXV
Package	6-Pin Ceramic	6-Pin Ceramic	6-Pin Ceramic	6-Pin Ceramic	6-Pin Ceramic	6-Pin Ceramic	4-Pin Ceramic	4-Pin Ceramic
Sensor Type	Transistor	Transistor	Transistor	Transistor	Transistor	Transistor	Transistor	Transistor
Isolation Voltage (Min ,000)	1	1	1	1	1	1	1	1
CTR (Min/Max)	25/N/A	60/N/A	100/500	50/NA	100/500	200/1,000	25/60	100/150
I_f (mA) Typ/Max	1/40	1/40	1/40	1/40	1/40	1/40	10/40	10/40
V_{CE} (V) Max	40	40	40	40	40	40	30	30
Rise/Fall Times (Max. μ s)	15/15	15/15	20/20	20/20	20/20	20/20	15/15	20/20

Optek, Минск +375447584780 über email: optek17@ut.by

High-Reliability JAN Isolators

High-reliability JAN isolators from TT Electronics feature a choice of either hermetically sealed TO-78 package or surface mountable SM/LCC package. Each isolator in this series consists of an infrared emitting diode and a NPN silicon phototransistor, which are mounted in a hermetically sealed TO-78/SMD package. Devices are designed for military and/or harsh environments. They feature a high current transfer ratio and 1 kV electrical isolation as standard.

High-Reliability JAN Isolators



Model Number*	4N22(A)(U)	4N23(A)(U)	4N24(A)(U)	4N47(A)(U)	4N48(A)(U)	4N49(A)(U)
Package	TO-78/SMD	TO-78/SMD	TO-78/SMD	TO-78/SMD	TO-78/SMD	TO-78/SMD
CTR (Min/Max)	40/N/A	60/N/A	100/N/A	50/N/A	100/500	200/1000
Isolation Voltage (Min. kV)	1	1	1	1	1	1
I_f (mA) Max	40	40	40	40	40	40
V_{CE} (V) (Max)	35	35	35	40	40	40
Rise/Fall Times (Max. μ s)	15	15	20	20	20	25
Slash Sheet (MIL-PRF-19500)	486	486	486	548	548	548
RoHS	No	No	No	No	No	No

* Available in JAN, JANTX, JANTXV and non-JAN COTS versions.

"A" suffix denotes collector electrically isolated from case.

"U" suffix denotes SMD/LCC 6 6-pin version.

Optek, Минск +375447584780 viber email minsk17@tul.by

High-Reliability COTS Optoelectronics

The TT Electronics components family consists of GaAIAs/GaAs LEDs, photodarlingtons, photodiodes, Photologic® detectors (integrated detector), phototransistors and VCSELs. Components are available in both metal packages (Pill, TO-5, TO-18, TO-46) and plastic packages (T-1, T-1 3/4, endlooker, sidelooker). In addition to these standard offerings, TT Electronics can provide custom designs at OEM volumes in shorter lead times than can often be found among other industry off-the-shelf-solutions.

High-Reliability Hallogic Hall-Effect Sensors

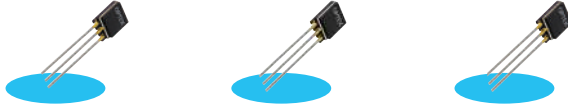

Model Number	OMH3040B	OMH3075B	OMH3075S
Package	Side Sensing Ceramic	Side Sensing Ceramic	Side Sensing Ceramic
Output Type	Uni-Polar Non-Latching	Bi-Polar Latching	Bi-Polar Latching
Operating Point Gauss (Min/Typ/Max)	70/150/200	50/150/250	50/150/250
Release Point Gauss (Min/Typ/Max)	50/115/180	-250/-150/-50	-250/-150/-50
Hysteresis Gauss (Min/Typ/Max)	110/35/60	100/300/500	100/300/500
V _{CC} (Volts) Min/Max	4.5/24.0	4.5/24.0	4.5/24.0
RoHS	No	No	No

Photologic® Slotted Optical Switches



Model Number	OPB930W51Z	OPB973N51
Package	Slotted T	Slotted N
Sensor Type	Totem-Pole	Inv. Open-Collector
Gap Width/Depth	0.125"/0.315"	0.125"/0.345"
Aperture Emitter/Sensor	0.05"/0.01"	0.05"/0.01"
Wavelength (nm) (Typ)	880	890
I _F (mA) Typ/Max	20/50	20/50
I _{CCL} /I _{CCH} (mA) Max	15/15	15/15
V _{CC} (Volts) Min/Max	4.75/5.25	4.5/16.0
Lead Length/Spacing	24"/26 AWG Wire	0.425"/0.320"

High-Reliability GaAIAs Infrared Emitting Diode



Model Number	OP224S
Package	Pill Dome Lens
LED Wavelength (nm) (Typ)	890
Output Power (μW) Min	1.5
I _F (mA) Typ/Max	50/100
Beam Angle (Degrees)	24
Lead Length	N/A

High-Reliability Hermetic Infrared Emitting Diode

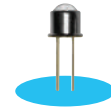

Model Number	OP236TX
Package	TO-46 Dome Lens
LED Wavelength (nm) (Typ)	890
Output Power (μW) Min	3.5
I _F (mA) Typ/Max	50/100
Beam Angle (Degrees)	18
Lead Length	0.50"

High-Reliability Optically Coupled Isolator

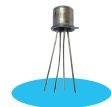

Model Number	3C92CTX
Package	TO-72
LED Wavelength (nm) (Typ)	935
Sensor Type	Transistor
CTR (Min/Max)	0.3/2.0
Isolation Voltage (Min, 000)	1
I _F (mA) Typ/Max	10/50
V _{CE} (V) Typ/Max	10/50
Rise/Fall Times (Max, μs)	N/A

High-Reliability COTS Hall Effect

High-reliability COTS sensors from TT Electronics offer reliable performance, low form factor, and extended service life across a variety of applications. These standard offerings are available with short lead times, as well as in assorted styles and types.

Hallogic Hall Effect Sensors Hall Ceramic

Model Number	OMH090 OMH090B OMH090S	OMH3019 OMH3019B OMH3019S	OMH3020 OMH3020B OMH3020S	OMH3040 OMH3040B OMH3040S	OMH3075 OMH3075B OMH3075S	OMH3131 OMH3131B OMH3131S	OMH3150 OMH3150B OMH3150S
Package	Side Sensing 3-Leaded Ceramic	Side Sensing 3-Leaded Ceramic	Side Sensing 3-Leaded Ceramic	Side Sensing 3-Leaded Ceramic	Side Sensing 3-Leaded Ceramic	Side Sensing 3-Leaded Ceramic	Side Sensing 3-Leaded Ceramic
Output Type	Uni-Polar Non-Latching	Uni-Polar Non-Latching	Uni-Polar Non-Latching	Uni-Polar Non-Latching	Bi-Polar Latching	Uni-Polar Non-Latching	Ratiometric
Operating Point Gauss (Min /Typ/Max)	70/90/220	175/300/500	70/220/350	70/150/200	50/150/250	20/60/95	2.5 mV/G
Release Point Gauss (Min /Typ/Max)	30/65/180	125/235/420	50/180/330	50/115/180	-250/-150/-50	10/45/85	N/A
Hysteresis Gauss (Min /Typ/Max)	10/30/60	30/100/155	15/55/200	10/35/60	100/250/500	5/15/40	2.5 mV/G
V _{CC} (Volts) (Min/Max)	4.5/24.0	4.5/24.0	4.5/24.0	4.5/24.0	4.5/24.0	4.5/24.0	4.5V/6.0V

Hallogic Hall Effect Sensor Assemblies

Model Number	OHB3040	OHB3040B	OHB3040S
Package	Slotted Switch	Slotted Switch	Slotted Switch
Output Type	Logic	Logic	Logic
Right Operate Point (Min)*	0.073" [1.85 mm]	0.073" [1.85 mm]	0.073" [1.85 mm]
Right Operate Point (Max)*	0.003" [0.08 mm]	0.003" [0.08 mm]	0.003" [0.08 mm]
Right Release Point (Min)*	0.045" [1.14 mm]	0.045" [1.14 mm]	0.045" [1.14 mm]
Right Release Point (Max)*	-0.005" [-0.127 mm]	-0.005" [-0.127 mm]	-0.005" [-0.127 mm]
Left Release Point (Min)*	-0.045" [-1.14 mm]	-0.045" [-1.14 mm]	-0.045" [-1.14 mm]
Left Release Point (Max)*	0.005" [0.127 mm]	0.005" [0.127 mm]	0.005" [0.127 mm]
Left Operate Point (Min)*	-0.073 [-1.85 mm]	-0.073 [-1.85 mm]	-0.073 [-1.85 mm]
Left Operate Point (Max)*	-0.003" [-0.08 mm]	-0.003" [-0.08 mm]	-0.003" [-0.08 mm]
V _{CC} (Volts) (Min/Max)	4.5/25	4.5/25	4.5/25

	Right Operate Point	Right Release Point	Left Release Point	Left Operate Point
Minimum	0.073" [1.85mm]	0.045" [1.14mm]	-0.045" [-1.14mm]	-0.073" [-1.85mm]
Maximum	0.003" [0.08mm]	-0.005" [-0.127mm]	0.005" [0.127mm]	-0.003" [-0.08mm]

Measurements are referenced to Center Line.

LEDs

High-Reliability Photologic® Hermetic Sensors



Model Number	OP223TX OP223TXV	OP224ESA-B1, -B2 and -B3; -C1, -C2 and -C3	OP224S OP224TX OP225TXV	OP235TX OP235TXV	OP236TX OP236TXV
Package	Pill Dome Lens	Pill Dome Lens	Pill Dome Lens	TO-46 Dome Lens	TO-46 Dome Lens
LED Wavelength (nm)	890	890	890	890	890
Output Power (mW) Min	1	1.5	1.5	1.5	3.5
I _F (mA) Typ/Max	50/100	50/100	50/100	50/100	50/100
Beam Angle (Degrees)	24	24	24	18	18
Lead Length	N/A	N/A	N/A	0.50"	0.50"

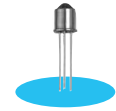

Model Number	OPL800TX OPL800TXV
Package	Hermetic, Lensed TO-18
Photologic	Totem-Pole
Irradiance (mW/cm ²)	3
V _{CC} (V) Typ/Max	4.5 - 10.0
Lead Length	0.50"

Optically Coupled Isolators



Model Number	3C91CTX 3C91CTXV	3C92CTX 3C92CTXV	3N243TX	3N244TX	3N245TX	3N261TX	3N262TX	3N263TX
Package	TO-72	TO-72	TO-72	TO-72	TO-72	TO-72	TO-72	TO-72
LED Wavelength (nm)	935	935	880	880	880	880	880	880
Sensor Type	Transistor	Transistor	Transistor	Transistor	Transistor	Transistor	Transistor	Transistor
CTR (Min/Max)	0.3/1.90	0.3/2.0	0.15/N/A	0.3/N/A	0.6/N/A	0.5/N/A	1/5	2/10
Isolation Voltage (Min ,000)	1	1	1	1	1	1	1	1
I _F (mA) Typ/Max	10/50	10/50	3/40	3/40	3/40	1/40	1/40	1/40
V _{CE} (V) Typ/Max	10/50	10/50	10/30	10/30	10/30	5/30	5/30	5/30
Rise/Fall Times (Max. μs)	N/A	N/A	10	10	10	20	20	25

High-Reliability Optically Coupled Isolators

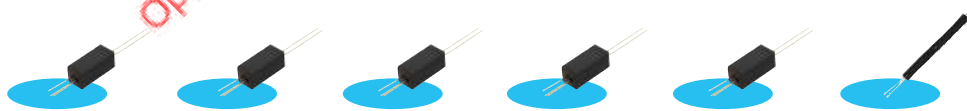

Model Number	OPI120 OPI120TX OPI120TXV	OPI123	OPI125 OPI125TX OPI125TXV	OPI126	OPI127	OPI150 OPI150TX OPI150TXV
Package	Axial Channel	Axial Channel	Axial Channel	Axial Channel	Axial Channel	Axial-Cylindrical
LED Wavelength (Nm)	890	890 or 935	890 or 935	935	890	890
Sensor Type	Transistor	Darlington	Totem Pole	Open Collector	Inv-Totem Pole	Transistor
CTR (Min/Max)	20	50	Logic 15 mA	Logic 15 mA	Logic 15 mA	10
t _{PLH} /t _{PHL} Typ (ns)	N/A	N/A	N/A	N/A	5/5	N/A
Isolation Voltage (Min ,000)	15	15	15	15	15	50
I _F (mA) Typ/Max	10/50	10/50	7.5/25	7.5/25	7.5/25	16/100
V _{CE} (V) Typ/Max	5/25	20	35	35	35	5/30
Lead Length/Spacing	0.44"/0.90"	0.40"/0.75"	0.44"/0.90"	0.40"/0.75"	0.40"/0.75"	0.40"/3.16"

High-Reliability NPN Silicon Phototransistors

Sensor Type: Transistor (ALL)



Model Number	OP602TX OP602TXV	OP603TX OP603TXV	OP604ESA-B1, -B2, -B3; -C2, -C2, -C3	OP604S OP604TX OP604TXV	OP803TX OP803TXV	OP804TX OP804TXV	OP805TX OP805TXV
Package	Low Lens	Low Lens	Low Lens	Low Lens	TO-18/46 Dome Lens	TO-18/46 Dome Lens	TO-18/46 Dome Lens
Light Current $I_{C(ON)}$ (μ A) Min/Max	2/5	4/8	7/N/A	7/N/A	4/8	7/22	15/N/A
V_{CE} (V) Typ/Max	5/50	5/50	5/50	5/50	5	5	5
Input Radiance EE (mW/cm ²)	20	20	20	20	5	5	5
Viewing Angle (Degrees)	35	35	35	35	25	25	25
Lead Length	N/A	N/A	N/A	N/A	0.5"	0.5"	0.5"

Slotted Switches - Transistor Type Sensor (ALL)



Model Numbers	OPB821TX OPB821TXV	OPB847TX OPB847TXV	OPB848TX OPB848TXV
Package Type	Slotted Wires	Slotted N	Slotted N
LED Wavelength (nm)	880	890	890
Slot Width/Depth	0.080"/0.255"	0.100"/0.250"	0.100"/0.250"
Light Current $I_{C(ON)}$ (mA) Min	0.8	4	1
I_f (mA) Typ/Max	20/50	20/30	20/30
V_{CE} (V) Typ/Max	30	30	30
Aperture Emitter/Sensor	0.04"/0.04"	0.025"/0.025"	0.06"/0.06"
Lead Length/Spacing	24"/26 AWG Wire	0.425"/0.300"	0.425"/0.300"

Slotted Switches - Transistor Type Sensor (ALL)

Package Type: Slotted L



Model Numbers	OPB870L11TX OPB870L11TXV	OPB870L51TX OPB870L51TXV	OPB870L55TX OPB870L55TXV	OPB871L51TX OPB871L51TXV	OPB871L55TX OPB871L55TXV	OPB872L51TX OPB872L51TXV	OPB872L55TX OPB872L55TXV
LED Wavelength (nm)	890	890	890	890	890	890	890
Slot Width/Depth	0.125"/0.345"	0.125"/0.345"	0.125"/0.345"	0.125"/0.345"	0.125"/0.345"	0.125"/0.345"	0.125"/0.345"
Light Current $I_{C(ON)}$ (mA) Min	0.5	0.5	0.5	1.0	1.0	1.8	1.8
I_f (mA) Typ/Max	20/50	20/50	20/50	20/50	20/50	20/50	20/50
V_{CE} (V) Typ/Max	50	50	50	50	5/50	50	50
Aperture Emitter/Sensor	0.01"/0.01"	0.05"/0.01"	0.05"/0.05"	0.05"/0.01"	0.05"/0.05"	0.05"/0.01"	0.05"/0.05"
Lead Length/Spacing	0.425"/0.320"	0.425"/0.320"	0.425"/0.320"	0.425"/0.320"	0.425"/0.320"	0.425"/0.320"	0.425"/0.320"







Slotted Switches - Transistor Type Sensor (Continued)

Package Type: Slotted N

							
Model Numbers	OPB870N11TX OPB870N11TXV	OPB870N51TX OPB870N51TXV	OPB870N55TX OPB870N55TXV	OPB871N51TX OPB871N51TXV	OPB871N55TX OPB871N55TXV	OPB872N51TX OPB872N51TXV	OPB872N55TX OPB872N55TXV
LED Wavelength (nm)	890	890	890	890	890	890	890
Slot Width/Depth	0.125"/0.345"	0.125"/0.345"	0.125"/0.345"	0.125"/0.345"	0.125"/0.345"	0.125"/0.345"	0.125"/0.345"
Light Current IC(ON) (mA) Min	0.5	0.5	0.5	1.0	1.0	1.8	1.8
I _F (mA) Typ/Max	20/50	20/50	20/50	20/50	20/50	20/50	20/50
V _{CE} (V) Typ/Max	50	50	50	5/50	5/50	50	50
Aperture Emitter/Sensor	0.01"/0.01"	0.05"/0.01"	0.05"/0.05"	0.05"/0.01"	0.05"/0.05"	0.05"/0.01"	0.05"/0.05"
Lead Length/Spacing	0.425"/0.320"	0.425"/0.320"	0.425"/0.320"	0.425"/0.320"	0.425"/0.320"	0.425"/0.320"	0.425"/0.320"









Slotted Switches - Transistor Type Sensor (Continued)

Package Type: Slotted P

							
Model Numbers	OPB870P11TX OPB870P11TXV	OPB870P51TX OPB870P51TXV	OPB870P55TX OPB870P55TXV	OPB871P31TX OPB871P51TXV	OPB871P55TX OPB871P55TXV	OPB872P51TX OPB872P51TXV	OPB872P55TX OPB872P55TXV
LED Wavelength (nm)	890	890	890	890	890	890	890
Slot Width/Depth	0.125"/0.345"	0.125"/0.345"	0.125"/0.345"	0.125"/0.345"	0.125"/0.345"	0.125"/0.345"	0.125"/0.345"
Light Current IC(ON) (mA) Min	0.5	0.5	0.5	1.0	1.0	1.8	1.8
I _F (mA) Typ/Max	20/50	20/50	20/50	20/50	20/50	20/50	20/50
V _{CE} (V) Typ/Max	50	50	50	50	50	50	50
Aperture Emitter/Sensor	0.01"/0.01"	0.05"/0.01"	0.05"/0.05"	0.05"/0.01"	0.05"/0.05"	0.05"/0.01"	0.05"/0.05"
Lead Length/Spacing	0.425"/0.320"	0.425"/0.320"	0.425"/0.320"	0.425"/0.320"	0.425"/0.320"	0.425"/0.320"	0.425"/0.320"

Slotted Switches - Transistor Type Sensor (Continued)

Package Type: Slotted T

								
Model Numbers	OPB870T11TX OPB870T11TXV	OPB870T51TX OPB870T51TXV	OPB870T55TX OPB870T55TXV	OPB871T51TX OPB871T51TXV	OPB871T55TX OPB871T55TXV	OPB872T11TX OPB872T11TXV	OPB872T51TX OPB872T51TXV	OPB872T55TX OPB872T55TXV
LED Wavelength (nm)	890	890	890	890	890	890	890	890
Slot Width/Depth	0.125"/0.345"	0.125"/0.345"	0.125"/0.345"	0.125"/0.345"	0.125"/0.345"	0.125"/0.345"	0.125"/0.345"	0.125"/0.345"
Light Current IC(ON) (mA) Min	0.5	0.5	0.5	1.0	1.0	1.8	1.8	1.8
I _F (mA) Typ/Max	20/50	20/50	20/50	20/50	20/50	20/50	20/50	20/50
V _{CE} (V) Typ/Max	30	30	50	5/50	5/50	50	50	50
Aperture Emitter/Sensor	0.01"/0.01"	0.05"/0.01"	0.05"/0.05"	0.05"/0.01"	0.05"/0.05"	0.01" / 0.01"	0.05"/0.01"	0.05"/0.05"
Lead Length/Spacing	0.425"/0.320"	0.425"/0.320"	0.425"/0.320"	0.425"/0.320"	0.425"/0.320"	0.425"/0.320"	0.425"/0.320"	0.425"/0.320"

Transistors



Model Number	2N2222AUA 2N2222AUATX 2N2222AUATXV	2N2222AUB 2N2222AUBTX 2N2222AUBTXV	2N2907AUA 2N2907AUATX 2N2907AUATXV	2N2907AUB 2N2907AUBTX 2N2907AUBTXV	2N4854U 2N4854UTX 2N4854UTXV	2N5794U 2N5794UTX 2N5794UTXV	2N5796U 2N5796UTX 2N5796UTXV	2N6987U 2N6987UTX 2N6987URXV	2N6989U 2N6989UTX 2N6989UTXV
Package	4-Pin Ceramic	3-Pin Ceramic	4-Pin Ceramic	3-Pin Ceramic	6-Pin Ceramic	6-Pin Ceramic	6-Pin Ceramic	20-Pin Ceramic	20-Pin Ceramic
Sensor Type	NPN Transistor	NPN Transistor	PNP Transistor	PNP Transistor	NPN & PNP Transistor	Dual-NPN Transistor	Dual-PNP Transistor	Quad-PNP Transistor	Quad-NPN Transistor
H_{FE} Min/Max	50/325	50/325	75/450	75/450	50/300	35/300	75/300	75/450	50/325
V_{CE0} (Volts) Max	50	50	60	60	40	40	60	60	50
Rise/Fall Times Max (ns)	35/300	35/300	45/300	45/300	45/300	45/310	50/140	45/300	35/300

Reflective Switches Sensor Type: Transistor



Model Number	OPB700TX OPB700TXV
Package	Reflective Switch
LED Wavelength (nm)	890
Reflection Distance in (mm)	0.200 (5.08)
$I_{C(ON)}$ (μ A) Min	0.05
I_f (mA) Typ/Max	40/50
V_{CE} (V) Typ/Max	5/50
Wire Length	24"/26 AWG Wire

Surface Mount Optically Coupled Isolators



Model Number	HCC240TX HCC240TXV	HCC242TX HCC242TXV	HCC240TX HCC240TXV	HCC242TX HCC242TXV
Package	4-Pin Ceramic	4-Pin Ceramic	4-Pin Ceramic	4-Pin Ceramic
Sensor Type	Transistor	Transistor	1	1
CTR (Min/Max)	25/60	100/150	10/40	10/40
Isolation Voltage (Min, 000)	1	1	5.0/30	5.0/30
I_f (mA) Typ/Max	5.0/30	5.0/30	15/15	20/20
V_{CE} (V) Typ/Max	10/15	10/20	15/20	15/20
Rise/Fall Times Max (μ s)	15/20	15/20		

Surface Mount MOS and M0SFET Transistors



Model Number	HCT7000MTX HCT7000MTXV	HCT802TX HCT802TXV
Package	3-Pin Ceramic	6-Pin Ceramic
Sensor Type	N-Channel Enhanced MOSFET	N&P-Channel Enhanced MOSFET
V_{DSS} (Volts) Min	60	90
$V_{GS(TH)}$ (Volts) Min/Max	0.8/3.0	0.5/2.5 & -2.0/-4.5
$I_D(ON)$ (mA) Min	75	1.5 & -1.1
G_{fs} (ms) Min	100	170 & 200
t(ON)/t(OFF) (ns) Max	10/10	15/17 & 50/50

Fiber Optics

Fiber optic detectors, receivers and transmitters from TT Electronics provide highly reliable electronic signal transmission over extended distances, as well as over their full signal capacity. Fiber optic detectors convert optical signals back into electrical impulses used at the receiving end of the fiber optic data links. The receivers are used to accept these signals. Fiber optic transmitters are then used to convert an electrical input into an optical output from a laser diode or LED. These products are also available with a full range of customisation options to support specific requirements.

Fiber Optic Detector



Model Number	OPF482
Package	ST-Tall
Responsivity (mA/mW) Typ	0.45
tr/ta (Typ)(ns)	2
Reverse Voltage (Max)	100

Fiber Optic Transmitters



Model Number	OPF372A
Package	ST-Tall
Wavelength (nm)	850
Coupled Power (dbm/μW) Min	-16/25
I _f (mA) Typ/Max	100
tr/ta (Typ)(ns)	6.0/10.0

Vertical Cavity Surface Emitting Laser in T-1 Package



Model Number	OPV332
Package	T-1 Dome Lens
Wavelength (nm)	850
Total Output Power (mW 50/125) Min	1.5
I _f (mA) Typ/Max	7.0/12
Rise/Fall Time (ps)(Typ)	110/110
Beam Angle (Degrees) (Typ)	4°
Lead Length Min	0.55"
Laser Class	3B

Fiber Optic Transmitters



Model Number	OPF370A
Package	TO-18 Clear Cap
LED Wavelength (nm)	850
Output Power (μW) Min	25
I _f (mA) Typ/Max	100
Rise/Fall Time (ns)	8.0/10.0
Fiber Size (μm)	50/125
Lead Length	0.50"

Fiber Optic Receivers



Model Number	OPF520	OPF522	OPF2412
Package	TO-18 Green Cap	ST-Short	Cube/DIP ST-Panel
Data Rate (Max)	5 Mbps	5 MBd	5 Mbps
Receiver Type	Open Collector Schmitt	Open Collector Schmitt	Open Collector Schmitt
Input Sensitivity (dbm)/(μW)	-40/0.1	-40/0.1	-40/0.1
Responsivity (mV/μW) Min/Max	-	-	-
Peak Input Power (dBm/μW)	-9.2/120	-9.2/120	-9.2/120
Output Type	Digital	Digital	TTL or CMOS
Fiber Size (μm)	100/140	N/A	N/A

Oplek, Минск +375447584780 fiber email mask17@ut.by

VLEDs

VLEDs from TT Electronics are designed to meet or exceed the light output of other industry models. A unique product design features the integrating sphere, which detects the exact color (dominant wavelength or color temperature for white light), the peak wavelength, brightness (total luminous flux), and other parameters at a specified current level (IF). The VLEDs range is available as assemblies, signage and channel lettering, designer kits, flexible strips, surface mount, and module strings. They are also offered with a choice of single color, white, and RGB, as well as in a variety of package types. High power and through-hole mounted versions are also available.

Mini Half-Watt SMD 3.5 mm (120° Viewing Angle)



Model Number	OVS5MRBCR4	OVS5MGBCR4	OVS5MBBCR4
Package	3.5 mm mini half-watt	3.5 mm mini half-watt	3.5 mm mini half-watt
Material	AllnGaP	InGaN	InGaN
Color	Red	Green	Blue
Dominant λ D	625 nm	525 nm	465 nm
Lens Color	Clear	Clear	Clear
I_v at I_f =mA/Typ	140/7150 mcd	150/22 lm	150/6 lm
Viewing Angle (Degrees)	120°	120°	120°
V_f (Typ)	2.2	3.4	3.4

Full-Color 1204 SMD (150° Viewing Angle)



Model Number	OVSRRGBCC3	OVSRRGBCC3TM
Package	Side Mount	Top Mount
Material	R:AllnGaP G&B:InGaN	R:AllnGaP G&B:InGaN
Color	RGB	RGB
Dominant λ D	R:625 G:530 B:475	R:625 G:530 B:475
Lens Color	Clear	Clear
I_v at I_f =mA/Typ	R:105 G:330 B:110	R:105 G:330 B:110
Viewing Angle (Degrees)	150°	150°
V_f (Typ)	R:2.0 G&B:3.3	R:2.0 G&B:3.3

Full Color PLCC4 LED

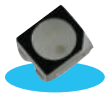

Model Number	OVSARGB4R8
Package	PLCC4
Material	AllnGaP, InGaN, InGaN
Color	RGB
Dominant λ D	622nm, 530 nm, 470 nm
Lens Color	Diffused
I_v at I_f =mA/Typ	635 mcd, 1000 mcd, 335 mcd
Viewing Angle (Degrees)	120°
V_f (Typ)	R=2.3 G=3.6 B=3.6

Flexible LED Light Strip 30 LEDs per strip



Model Number	OVQ12S30W7
Package	Flexible LED Light Strip
Material	InGaN
Color	White
Dominant λ D	5500°K
Lens Color	Clear
I_v at I_f =mA/Typ	68 lux@0.5m
Viewing Angle (Degrees)	120°
V_f (Typ)	12V

Optek, Минск +375447584780 viber@email_minsk17@optek.by

Steering Torque and Position Sensors

TT Electronics position and torque sensors are available in both single- and multi-turn versions, contacting or non-contacting, with a choice of either side or top adjustments, and plain, threaded or sleeve bushing types. Units offer rotational life ranging from single turn, to up to 1000K turns. In addition, TT Electronics offers a full line of rotary panel and slide potentiometers, linear motion sensors and actuators, multi-turn precision potentiometers, steering sensors, and cermet trimmers.

Steering Sensors



Model Number	SX-4289	SX-4300	SX-4388	SX-4400	SX-4404	SX-4413	SX-4414	SX-4417	SX-4428	SX-4429
Technology	contacting	contacting	contacting	magnetic	contacting	contacting	contacting	magnetic	magnetic	contacting
Torque Angle	± 8°	± 8°	± 8°	± 5°	± 5°	± 5°	± 5°	± 5°	± 5°	
Position Angle	360°	± 900°			± 900°		360°	± 900°		± 900°
# of Wires	6	7	4	4	7	4	6	8	4	5
Connector Model	Delphi 15336723	Delphi 15406142	Delphi 15336723	Yazaki 7122-8365	TE 1376352-1 connector	Yazaki 7122-8365	Yazaki 7122-8365	Delphi 15406142	Yazaki 7122-8365	Yazaki 7122-8365



Model Number	SX-4431	SX-4432	SX-4433	SX-4473	SX-4474	SX-4475	SX-4476	SX-4479	SX-4487	SX-4491
Technology	contacting	contacting	contacting	contacting	contacting	contacting	contacting	contacting	contacting	contacting
Torque Angle	± 8°	± 8°	± 8°	± 5°	± 5°	± 8°	± 8°	± 8°	± 8°	± 5°
Position Angle	± 900°		360°	360°	± 900°	360°	± 900°	360°	± 900°	360°
# of Wires	7	4	6	6	7	6	7	6	7	6
Connector Model	TE 1376352-1	TE 1376352-1	TE 1376352-1	Flex circuit	Delphi 15406142	Delphi 15406142	Delphi 15406142	Delphi 15406142	Delphi 15406142	Delphi 15406142

Rotary Encoders



Model Number	EN08-S	EN11-HSM	EN11-HSB	EN11-VSM	EN12-HS	EN12-VS	EN16-H	EN16-V
Size	8 mm	11 mm	11 mm	11 mm	12 mm	12 mm	16 mm	16 mm
Adjust	Side	Top	Top	Side	Top	Side	Top	Side
Pulses	10	15, 20	15, 20	15, 20	12, 24	12, 24	12, 24	12, 24
Detents	0, 20	0, 20, 30	0, 20, 30	0, 20, 30	0, 12, 24	0, 12, 24	0, 12, 24	0, 12, 24
Switch	Y	Y	Y	Y	Y	Y	N	N
Bushing Type	Threaded	Threaded	Plain	Threaded	Sleeve	Sleeve	Threaded	Threaded
Shaft	Metal	Metal	Metal	Metal	Plastic	Plastic	Plastic	Plastic
Life	50K	30K	30K	30K	30K	30K	30K	30K

Rotary Panel Potentiometers



Model Number	P08xN	P08xS	P090L	P090S	P09xS/N	P09x5N	P110KV/KVI	P110KH/KH1
Style	Side adj	Side adj	Side adj	Top adj.	Side adj	Top adj.	Side adj	Top adj.
Package Size	8 mm	8 mm	9 mm	9 mm	9 mm	9 mm	11 mm	11 mm
Element	Con. Plas.	Con. Plas.	Con. Plas.	Con. Plas.	Con. Plas.	Con. Plas.	Con. Plas.	Con. Plas.
Shaft	Metal	Metal	Plastic	Plastic	Metal	Metal	Plastic	Plastic
Bushing	Metal	Metal	N/A	N/A	Metal	Metal	Metal	Metal
Power Rating	0.05W	0.05W	0.03W	0.03W	0.05W	0.05W	0.05W	0.05W
Rotational Life	100K	100K	100K	100K	100K	100K	30K	30K
Switch	N/A	Y	N/A	N/A	Y	N/A	N/A	N/A
Multi-Ganged	4	4	N/A	N/A	8	2	N/A	N/A



Model Number	P120PK	P140KH/KH1	P160KN/KN2	P160KNPD	P160KNP	P170S/N	P170S2/N2	P170SP1/NP1
Style	Top adj.	Top adj.	Side adj. PC pin	Rear adj. PC pin	Solder lug	Solder lug	Side adj. PC pin	Top adj. PC pin
Package Size	12 mm	14 mm	16 mm	16 mm	16 mm	17 mm	17 mm	17 mm
Element	Con. Plas.	Con. Plas.	Con. Plas.	Con. Plas.	Con. Plas.	Con. Plas.	Con. Plas.	Con. Plas.
Shaft	Plastic	Plastic	Metal	Metal	Metal	Metal	Metal	Metal
Bushing	N/A	Metal	Metal	Metal	Metal	Metal	Metal	Metal
Power Rating	0.05W	0.2W	0.2W	0.2W	0.2W	0.1W	0.1W	0.1W
Rotational Life	100K	30K	100K	100K	100K	100K	100K	100K
Switch	N/A	N/A	Y	Y	Y	Y	Y	Y
Multi-Ganged	2	2	6	6	6	N/A	N/A	N/A



Model Number	P170SPD/NPD	P230	P231	P232	P260P	P260S (Switch)	P260D (Detent)	P260T	P261P	P270
Style	Rear ad. PC pin	Solder lug	Solder lug	Solder lug	Side adj. PC pin	Side adj. PC pin	Side adj. PC pin	Top adj. PC pin	Solder Lug	Solder Lug
Package Size	17 mm	24 mm	24 mm	24 mm	12.7 mm	12.7 mm	12.7 mm	12.7 mm	12.7 mm	27 mm
Element	Con. Plas.	Con. Plas.	Con. Plas.	Con. Plas.	Con. Plas.	Con. Plas.	Con. Plas.	Con. Plas.	Con. Plas.	Con. Plas.
Shaft	Metal	Metal	Metal	Metal	Metal	Metal	Metal	Metal	Metal	Metal
Bushing	Metal	Metal	Metal	Metal	Metal	Metal	Metal	Metal	Metal	Metal
Power Rating	0.1W	0.5W	0.5W	0.5W	0.5W	0.5W	0.5W	0.5W	0.5W	2.0W
Rotational Life	100K	500K	100K	2,000K	1,000K	100K	100K	1,000K	1,000K	1,000K
Switch	Y	N/A	N/A	N/A	N/A	Y	N/A	Y	N/A	N/A
Multi-Ganged	N/A	N/A	N/A	1	6	5	6	2	6	1

Rotary Single Turn Precision Potentiometers

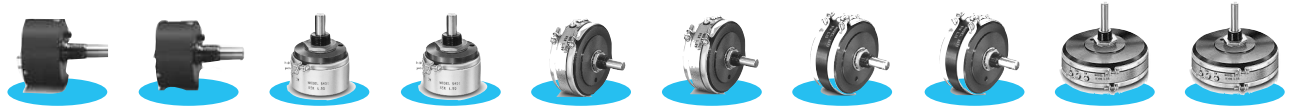

Model Number	6371	6373	5401	5403	5611	5613	6671	6673	5711	5713
Housing (OD)	1-5/16"	1-5/16"	1-7/16"	1-7/16"	2"	2"	2"	2"	3"	3"
Element*	CP	CP	WW	WW	WW	WW	CP	CP	WW	WW
Resistor Range (Ohms)	1K to 300K	1K to 300K	25 to 50K	25 to 50K	15 to 80K	15 to 80K	1K to 300K	1K to 300K	25 to 145K	25 to 145K
Standard Resistance Tolerance	±10%	±10%	±5%	±5%	±5%	±5%	±10%	±10%	±5%	±5%
Standard Linearity	±0.5%	±0.5%	±0.5% (<100 Ohms±1.0%)	±0.5% (<100 Ohms±1.0%)	±0.5% (<50 Ohms±1.0%)	±0.5% (<50 Ohms±1.0%)	±0.25%	±0.25%	±0.5%	±0.5%
Mounting Style	Bushing	Servo	Bushing	Servo	Bushing	Servo	Bushing	Servo	Bushing	Servo



Model Number	5101	5103	6138	6143	6163	6173	6186	6273	3371	5311
Housing (OD)	7/8"	7/8"	7/8"	7/8"	7/8"	7/8"	7/8"	1-1/16"	1-5/16"	1-5/16"
Element*	WW	WW	CP	CP	CP	CP	CP	CP	CP	WW
Resistor Range (Ohms)	200 to 15K	200 to 15K	1K to 60K	1K to 100K	1K to 100K	1K to 100K	1K to 100K	1K to 900K	1K to 900K	10 to 44.6K
Standard Resistance Tolerance	±5%	±5%	±20%	±10%	±10%	±10%	±10%	±10%	±10%	±3% (<40 Ohms±5%)
Standard Linearity	±0.5%	±0.5%	±1.0%	±1.0%	±1.0%	±0.5%	±1.0%	±0.5%	±0.5%	±0.5% (<250 Ohms±1.0%)
Mounting Style	Bushing	Servo	Bushing	Servo	Servo	Servo	Bushing	Servo	Bushing	Bushing

Rotary Multi-Turn Precision Potentiometers



Model Number	7383	7386	9301	9303	7481	7483	7486	7216
No of Turns	3	3	3	3	5	5	5	10
Housing (OD)	7/8"	7/8"	1-13/16"	1-13/16"	7/8"	7/8"	7/8"	7/8"
Element*	WW	WW	WW	WW	WW	WW	WW	WW, HYB
Resistor Range (Ohms)	100 to 30K	100 to 30K	30 to 90K	30 to 90K	100 to 50K	100 to 50K	100 to 50K	10 to 125K
Standard Resistance Tolerance	±5%	±5%	±5%	±5%	±5%	±5%	±5%	±3%
Standard Linearity	±0.50%	±0.50%	±0.25%	±0.25%	±0.30%	±0.30%	±0.30%	±0.25%
Mounting Style	Servo	Bushing	Bushing	Servo	Bushing	Servo	Bushing	Bushing

Rotary Multi-Turn Precision Potentiometers



Model Number	7221	7223	7274	7276	7284	7286	7288	8146	8148	7601	7603
No of Turns	10	10	10	10	10	10	10	10	10	10	10
Housing (OD)	7/8"	7/8"	7/8"	7/8"	7/8"	7/8"	7/8"	7/8"	7/8"	1-13/16"	1-13/16"
Element*	WW, HYB	WW, HYB	WW	WW	WW	WW	WW	HYB	HYB	WW	WW
Resistor Range (Ohms)	10 to 125K	10 to 125K	100 to 100K	100 to 100K	100 to 100K	100 to 100K	100 to 100K	1K to 100K	1K to 100K	1K to 650K	1K to 650K
Standard Resistance Tolerance	±3%	±3%	±5%	±5%	±5%	±5%	±5%	±10%	±10%	±5%	±5%
Standard Linearity	±0.25%	±0.25%	±0.25%	±0.25%	±0.25%	±0.25%	±0.25%	±0.25%	±0.25%	±0.15%	±0.15%
Mounting Style	Bushing	Servo	Bushing	Bushing	Bushing	Bushing	Bushing	Bushing	Bushing	Bushing	Servo

Precision Potentiometers



Model Number	A	B	C	D	E
No of Turns	10	15	3	25	40
Housing (OD)	1-13/16"	3-5/16"	1-13/16"	3-5/16"	3-5/16"
Element*	WW	WW	WW, HYB	WW	WW
Resistor Range (Ohms)	10 to 500K	40 to 2Meg	5 to 194.7K	60 to 3.3Meg	125 to 5.3Meg
Standard Resistance Tolerance	±3% (<100 Ohms=±5%)	±5%	±3%	±5%	±5%
Standard Linearity	±0.25% (<300 Ohms=±0.50%)	±0.50%	±0.50%	±0.50%	±0.50%
Mounting Style	Bushing	Bushing	Bushing	Bushing	Bushing

Slide Potentiometers



Model Number	PS45G	PS60G	PS100-1	PS100-2	PSxx-1	PSxx-2	PSxxL	PSxxM
Gang(s)	Dual	Dual	Single	Dual	Single	Dual	Single	Dual
Element	Con. Plas	Con. Plas	Con. Plas	Con. Plas	Con. Plas	Con. Plas	Con. Plas	Con. Plas
Power Ratio	0.25W	0.25W	0.25W	0.25W				
Cycle Life	200K	200K	100K	100K	100K	100K	100K	100K
Stroke Length	45 mm	60 mm	100 mm	100 mm	15 - 60 mm	16 - 60 mm	20 - 60 mm	20 - 60 mm
Dust Cover	Y	Y	N	N	N	N	Y	Y
Center Detent	N	N	N	N	Y	Y	Y	Y
LED	N	N	N	N	N	N	Y	N

Rotary Single Turn Non-Contacting Hall Effect Position Sensors



Model Number	6121	6124	6126	6127	6153
Housing	7/8"	7/8"	7/8"	7/8"	7/8"
Angle	35-360°	35-360°	35-360°	35-360°	35-360°
Standard Linearity	±0.5%	±0.5%	±0.5%	±0.5%	±0.5%
Mounting Style	1/8" Shaft 1/4" Bushing	6 mm Shaft 3/8" Bushing	1/8" Shaft 3/8" Bushing	1/4" Shaft 3/8" Bushing	Servo

Rotary Multi-Turn Non-Contacting Position Sensors

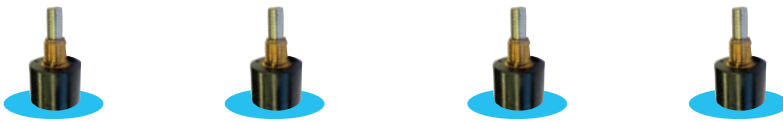

Model Number	8151	8152	8154	8156
Housing	7/8"	7/8"	7/8"	7/8"
Number of Turns	3, 5, 10	3, 5, 10	3, 5, 10	3, 5, 10
Standard Linearity	±0.5%	±0.5%	±0.5%	±0.5%
Mounting Style	1/8" Shaft, 1/4" Bushing	1/8" Shaft, 1/4" Servo Mount	6 mm Shaft, 3/8" Bushing	1/4" Shaft, 3/8" Bushing

Linear Potentiometers

Model 400 Series Linear Actuation Position Sensors
 Model 404 Series Spring Return, Linear Actuation Conductive Plastic Position Sensors
 Model 405 Series Low Cost, Linear Actuation Conductive Plastic Position Sensors

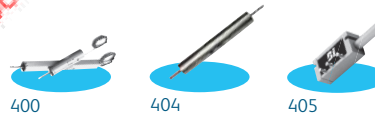

Single Turn Cermet Trimmers

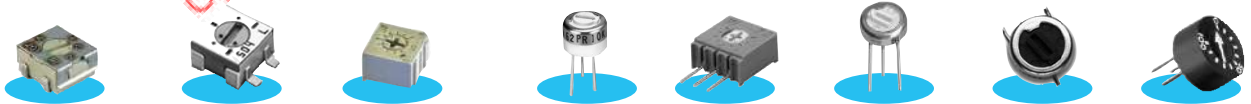

Model Number	22	23	25	62	72	82	83	93
Housing Size	3 mm Sq.	4mm Dia.	1/4" Sq.	1/4" Dia.	3/8" Sq.	1/4" Dia.	1/4" Sq.	1/2" Dia.
Adjustment Style	Top	Top	Top, Side	Top	Top, Side	Top, Side	Top, Side	Top
Mounting Style	Surface	Surface	Thru-Hole	Thru-Hole	Thru-Hole	Thru-Hole	Surface	Thru-Hole
Seal	Yes	Yes	Yes	Yes	Yes	Yes	Yes	Yes
Standard Resistance Range	100 to 2 Meg	10 to 2 Meg	10 to 2 Meg	10 to 1 Meg	10 to 2 Meg	10 to 1 Meg	10 to 1 Meg	20 to 2 Meg
Standard Resistance Tolerance	±20%	±20%	±10%	±10% (<100 Ohms=±20%)	±10% (<100 Ohms=±20%)	±10% (<100 Ohms=±20%)	±10% (<100 Ohms=±20%)	±10% (<100 Ohms=±20%)
Available Packaging	TR	TR, TB	AP (25U, 25V Only) TB (25U, 25V Only) TR		AP (72 RW Only) TB TR (72 RW Only)	AP (82W Only) TB TR (82W Only)	TB (83Y Only) TR (83Y Only)	

Multi-Turn Cermet Trimmers

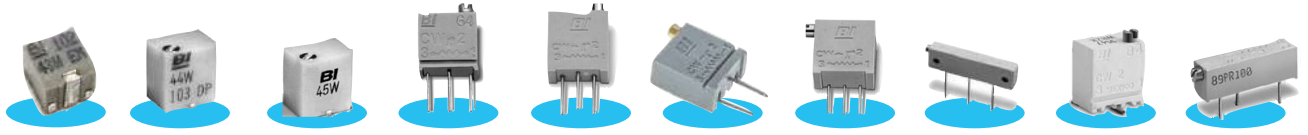

Model Number	43LF	44	45	64	66	67	68	78	84	89/90
Adjustment Turns	11	9	15	12	20	20	20	22	12	20
Housing Size	3 mm Sq.	4 mm Sq.	4 mm Sq.	1/4" Sq.	3/8" Sq.	3/8" Sq.	3/8" Sq.	1-1/4" Sq.	1/4" Sq.	3/4" Sq.
Adjustment Style	Top	Top, Side	Top, Side	Top, Side	Top, Side	Top, Side	Top, Side	Side	Top, Side	Side
Mounting Style	Surface	Surface	Surface	Thru-Hole	Thru-Hole	Thru-Hole	Thru-Hole	Thru-Hole	Surface	Thru-Hole
Seal	Yes	Yes	Yes	Yes	Yes	Yes	Yes	Yes	Yes	Yes
Standard Resistance Range	10 to 2 Meg	10 to 2 Meg	10 to 2 Meg	10 to 1 Meg	10 to 2 Meg	10 to 2 Meg	10 to 2 Meg	10 to 2 Meg	10 to 1 Meg	10 to 2 Meg
Standard Resistance	±20%	±10% (<100 Ohms=±20%)	±10% (<100 Ohms=±20%)	±10%	±10% (<100 Ohms=±20%)	±10% (<100 Ohms=±20%)	±10% (<100 Ohms=±20%)	±10% (<100 Ohms=±20%)	±10%	±10% (<100 Ohms=±20%)
Available Packaging	TR	TR TB	TR TB	TR AP (66y, 64Z Only)	TB TR AP (66W, 66X Only)	TB TR (67W, 67X Only) AP (67W, 67X Only)	TB TR (68W, 68X Only) AP (68W, 68X Only)	Boxes	TR	TB

Optek, Мінск +375447584780 viber email minsk17@tulby

Level Sensing Products

TT Electronics offers several key level sensing products for a wide range of test and measurement related applications. These include our intrinsically safe multi-spot thermometer, specified for high-accuracy spot-temperature measurements in a wide range of applications. It also includes the maintenance-free Latis, a combined temperature and water-interface sensor for use in tanks storing a wide range of liquids. Our innovative contactless autopad linear position sensor utilises inductive technology, offering zero mechanical wear and excellent EMI resistance, as well as good tolerance to geometric offsets in a robust, cost-competitive package.

Multi-Spot Thermometers

REF: DS2102

Accuracy	±0.15 + 0.002 x t tC			
	Sheath Construction	Type	Wire insulation	Temperature range
	Thick-wall Nylon 12 (Rilsan) tube	Standard Nylon	PVC throughout	-20 to +90°C
	Thin-wall AISI 316 Convolute Tube	Standard Stainless	PVC throughout	-20 to +90°C
		Extended Temperature Stainless	PTFE internal PVC external	-50 to +120°C
		High Temperature Stainless	PTFE with high-temperature elements	-50 to +200°C
		Cryogenic	PTFE	-200 to +50°C
		Bitumen	Double glass on nickel/copper wire	-20 to +280°C
Other	Maximum pressure	6 bar		
	Termination	Top fitting with a 12" (305 mm) long stainless steel pipe with 10" (254 mm) length, 1/2" BSP thread, or to customer specification.		
	Fittings	1 locking ring and nut as standard. Other fittings and flanges can be supplied.		
	Tank height	2 m to 40 m		
	Cabling	Colour-coded sleeved wires (max 10 m) For high temps, (-20 to +280°C) wires are numbered		
	Active level-probe length	150 mm to 1.5 m (450 mm length is standard)		
Construction	Immersed parts: AISI 316 stainless steel, PTFE, FEP and VITON for maximum corrosion resistance			
Approvals	The stainless steel MST is certified to conform to the ATEX directive 94/9/EC. The type of protection is EExia IIC T3 (Tamb = +160°C), certificate number BAS No. EX97D2042X.			



Latis

REF: DS2202

Accuracy	Water/Oil Level	Typically better than $\pm 1\%$ of probe length
	Temperature	$\pm 0.15 + 0.002 \times \text{ItI}^\circ\text{C}$
Repeatability	Water/Oil Level	Typically ± 0.5 mm or $\pm 0.1\%$ of active probe length, whichever is the greater
Output	Level Signal	4-20 mA (@ 10-30 Vdc)
Environmental	Operating Temperature	-20 to +80°C
	Maximum Pressure	6 bar
Construction	Immersed Parts: AISI 316 stainless steel, PTFE, FEP and VITON for maximum corrosion resistance	
Other	Active level-probe length	150 mm to 1.5 m (450 mm length is standard)
	Tank Height	2 m to 40 m
	Sleeved Wires Cabling	10 m maximum
Approvals	LATIS is certified to conform to the ATEX directive 94/9/EC. The type of protection is EExia IIC T4 (Tamb=80°C), certificate number BAS No.EX97D20242X.	

Autopad Linear Position Sensor

Interface	Analogue; 0-5 V ratiometric	Analogue; 0-5V	4-20 mA
Power Supply	4.5 – 5.5 Vdc	8-24V DC	8-24V DC
Current Consumption	20 mA	15 mA Max.	40 mA
Nominal Sensing Range (L) (mm)	75 mm/150 mm/250 mm		
Nominal Target - Sensor Separation	2 mm \pm 1.5 mm		
Sense Through Non-Conductive Material (eg: plastic, water, oil)	Yes		
Linearity	1 % full scale output		
Hysteresis	None		
Magnetic field resistance	Complete Immunity		
Resolution	12 bit		
Update Rate	250 μ s		
Operating Temperature Range	-20 to 70°C		
Electrical Connections	Brown: V+, Black: Output, Blue: Gnd		
Output Load	>1k Ω		
Reverse Polarity	Yes		
Overvoltage Protection	Yes, to 40 V		
Cable Length	0.5 m		
Sealing	IP67		
Approvals	CE, ROHS & WEEE		

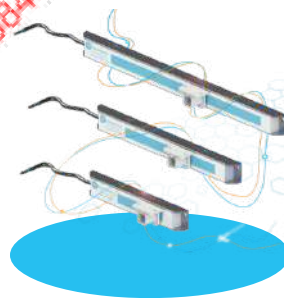

Oplek, Минск +375447584780 viber email: minsk17@ut.by

OEM Pressure Sensors

OEM pressure sensors from TT Electronics are available in standard ranges from 100mbar to 600bar. All ranges are available in gauge or absolute format. It is ideal for continuous use in applications where the pressure medium is wet and corrosive and long term stability is of prime importance.

Manufactured from high purity alumina ceramics, the OEM pressure sensor possesses superb chemical and abrasion resistance, making it unrivalled for use with virtually any pressure medium. The diaphragm of the sensing element has a four active-arm strain gauge bridge fused to its inner face. This direct fusion ensures excellent long term stability and repeatability, which, coupled with the matched bridge network, provides excellent linear thermal characteristics.

15 mm OEM Pressure Sensor REF: DS2902

Sensor Range (bar)	0.4	1.0	2.0	3.0	4	5	10	20	50	150	200
Thickness (mm normal)	6.20	6.20	6.26	6.26	6.31	6.31	6.38	6.49	6.49	7.06	7.28
Sensitivity mV/V $\pm 30\%$	1.3	3.7	2.8	4.3	3.4	4.2	4.5	4.8	6.4	5.4	5.4
Burst Pressure	3X sensor range minimum										
Sensor Diameter (mm)	14.80 mm - 15.00 mm										
Supply Voltage	1 - 30 Vdc										
Operating Temperature	-25°C to +125°C										
NL&H (% FRO.BSL)	< ± 0.25 (< ± 0.1 available)										
TZS (% FRO/°C)	< ± 0.07										
TSS (% FRO/°C)	<-0.04 typical										
Zero Output Laser Trim	< ± 0.2 mV/V										
Bridge Resistance	10K $\pm 30\%$										
Long Term Stability	< $\pm 0.1\%$ /y@25°C										
Material	96 % AL ₂ O ₃ ceramic										



19 mm OEM Pressure Sensor

Sensor Range (bar)	0.1	0.4	1.0	2.0	3	5	10	20	50	100	200	400	600
Thickness (mm normal)	6.2	6.2	6.2	6.3	6.4	6.4	6.5	6.6	6.8	7.3	7.8	8.6	9.5
Sensitivity mV/V $\pm 30\%$	0.2	1.8	3.0	3.0	3.0	3.5	4.5	5.0	5.0	4.5	5.0	4.0	3.0
Burst Pressure	3X sensor range minimum												
Sensor Diameter (mm)	18.60 - 19.00												
Supply Voltage	1 - 30 Vdc												
Operating Temperature	-40°C to +120°C												
NL&H (% FRO.BSL)	< ± 0.25 (< ± 0.1 available)												
TZS (% FRO/°C)	<1 bar(g) <0.2% span/°C												
	1-3 bar(g) <0.07% span/°C												
	>5 bar(g) <0.04% span/°C												
	<3 bar(a) <0.2% span/°C												
	5-10 bar(a) <0.07% span/°C												
	>20 bar(a) <0.04% span/°C												
TSS (% FRO/°C)	<-0.04 typical												
Zero Output Laser Trim	< ± 0.2 mV/V												
Bridge Resistance	10K $\pm 30\%$												
Long Term Stability	< $\pm 0.1\%$ /y@25°C												
Material	96 % AL ₂ O ₃ ceramics												



Pressure Sensors and Transducers

Pressure transmitters and transducers from TT Electronics offer superb chemical and corrosion resistance. A choice of either gauge or absolute pressure is detected using a four active arm strain gauge bridge sensor, fused to a high-purity ceramic diaphragm. Models are available in several classes of accuracy and compensation specified below, with ranges from 100 mbar to 600 bar or scaled to customer requirements. Industry specific certifications may also be available. Please consult the factory for details.

TPL Series OEM Pressure Sensor

Gauge Pressure Range	0-4 to 0-10 bar
Output Type	Voltage (0.5 V to 4.5 V ratiometric)
Output Span	4.0 Vdc \pm 1% of span
Output Zero	0.5 Vdc \pm 1%
Non Linearity, Hysteresis & Repeatability	\pm 0.25% of span (best fit straight line)
Compensated Temperature Range	0°C to +80°C
Operating Temperature Range	-20°C to 125°C
Thermal Zero Shift	\pm 0.04% of span /°C
Thermal Span Shift	\pm 0.015% reading /°C typical
Long Term Stability	\pm 0.1% /12 months typical
Power Supply	5 Vdc \pm 0.25 Vdc
Over Pressure	21 bar for 15 seconds @ +20°C
Burst Pressure	>35 bar
Pressure Connection Options	G 1/4" BSP male or female G 1/2" BSP male 1/4" NPT male or female 1/2" NPT male Vernon Morris QR Metric threads (M10, M14, M16, M18 & 20) Contact factory for additional pressure connections
Electrical Connection Options	IP65 mini-DIN (40050) plug & socket IP65 cable & ferrule IP65 large-DIN (43650) plug & socket IP68 glanded cable IP6K9K DIN Bayonet Contact factory for additional electrical connections
Housings	316L Stainless Steel (Brass upon request; contact factory for additional options)
Seals	Viton (Nitrile, EPDM, Chemraz upon request)



HPS-A Series Active Voltage Output Pressure Transducer REF: DS2806

Output Span	4V \pm 0.5%
Output Zero	1V \pm 0.5% of span
Non Linearity, Hysteresis & Repeatability (NLH)	\pm 0.1% of span (best fit straight line)
Compensated Temp Range	-20°C to 125°C
Operating Temp Range	-20°C to 125°C
Thermal Zero Shift	0 to 100°C, \pm 0.01% of span / °C < 0°C & > 100°C, \pm 0.015% span / °C
Thermal Span Shift	\pm 0.015% reading /°C typical
Long Term Stability	0.1% /12 months typical
Power Supply	10 to 32 Vdc



HPS - C Series Rationalised mV Output Pressure Transducer



Output Span	Dependent on range, ± 1 mV
Output Zero	0 mV \pm 0.1 mV/V
Non Linearity, Hysteresis & Repeatability (NLH)	$\pm 0.2\%$ of span (best fit straight line)
Compensated Temp Range	-20°C to 125°C
Operating Temp Range	-20°C to 125°C
Thermal Zero Shift	<0 to 100°C, $\pm 0.01\%$ span / °C < 0°C & >100°C, $\pm 0.015\%$ span / °C
Thermal Span Shift	$\pm 0.015\%$ reading/°C typical
Long Term Stability	0.1%/12 months typical
Power Supply	2-10 Vdc regulated

HPS - A Series 4-20 mA Pressure Transmitter REF: DS2805



Output Span	16 mA $\pm 0.5\%$
Output Zero	4 mA $\pm 0.5\%$ of span
Non Linearity, Hysteresis & Repeatability (NLH)	$\pm 0.1\%$ of span (best fit straight line)
Compensated Temp Range	-20°C to 125°C
Operating Temp Range	-20°C to 125°C
Thermal Zero Shift	0 to 100°C, $\pm 0.01\%$ of span / °C < 0°C & >100°C, $\pm 0.015\%$ span / °C
Thermal Span Shift	$\pm 0.015\%$ reading/°C typical
Long Term Stability	0.1%/12 months typical
Power Supply	10 to 32Vdc
Loop Resistance	1.1k Ω max @32Vdc supply

HPS-A Series Active mV Output Pressure Transducers REF: DS2807

Class A



Class B



Class C



	Class A	Class B	Class C
Output Span	200 mV $\pm 0.5\%$ (others available)	200 mV $\pm 1\%$ (others available)	200 mV $\pm 1\%$ (others available)
Output Zero	0 mV $\pm 0.5\%$ of span	0 mV $\pm 1\%$ of span	0 mV $\pm 1\%$ of span
Non Linearity, Hysteresis & Repeatability (NLH)	$\pm 0.1\%$ of span (best fit straight line)	$\pm 0.15\%$ of span (best fit straight line)	$\pm 0.25\%$ of span (best fit straight line)
Compensated Temp Range	-20°C to 125°C	0°C to 100°C	0°C to 80°C
Operating Temp Range	-20°C to 125°C	-20°C to 125°C	-20°C to 125°C
Thermal Zero Shift	0 to 100°C, $\pm 0.01\%$ of span / °C <0°C & >100°C, $\pm 0.015\%$ span / °C	$\pm 0.015\%$ span / °C	$\pm 0.04\%$ span / °C
Thermal Span Shift	$\pm 0.015\%$ reading/°C typical	$\pm 0.015\%$ reading/ °C typical	$\pm 0.015\%$ reading/°C typical
Long Term Stability	0.1%/12 months typical	0.1%/12 months typical	0.1%/12 months typical
Power Supply	10 to 32 Vdc	10 to 32 Vdc	10 to 32 Vdc

Flush Mounting and Abrasive Media

Flush mounting and abrasive media products from TT Electronics offer unrivaled abrasion resistance. They are both robust and high quality, and are available with a choice of either a cable or integrated connector configuration. Both types incorporate a four active arm strain gauge bridge fused to a high purity ceramic diaphragm. This offers high natural output coupled with superb chemical and corrosion resistance. The units have been designed primarily for use with slurry and other abrasive fluids. They feature a cavity free, flush sensing diaphragm covered by a flexible polypropylene shield.

Abrasive Material Pressure Transmitter P6420-57 (Cable) or P6420-67 (Niphan plug and socket)

Pressure Range	5, 10, 20, & 50 bar SG and G
Excitation	10-32 Vdc unregulated
Output	Span: 16 mA \pm 1 % of span at pressure
	Zero: 4 mA \pm 1 % of span at zero pressure
Output Type	4-20 mA
Non Linearity, Hysteresis & Repeatability (NLH)	< \pm 1 % of span (best fit straight line)
Operating Temp Range	-25°C to +100°C
Safe Over-range	1.5 times rated range
Burst Pressure	3 times rated range minimum
Insulation Resistance	>500M Ω at 500 Vdc, over the full operating temperature range
Loading Driving	1k Ω @ 28 Vdc supply
Environmental Protection	IP68 (P6420-57-Cable) or IP66 (P6420-67 Niphan plug and socket)
Electrical Connections	IP68 Cable PUR or Niphan plug and socket
Cable Length (m)	3

Model Number (Cable)	PP6420-010-57	PP6420-016-57	PP6420-020-57	PP6420-035-57
Pressure Range (bar)	0-10	0-16	0-20	0-35

Model Number (Plug & Socket)	PP6420-010-67	PP6420-016-67	PP6420-020-67	PP6420-035-67
Pressure Range (bar)	0-10	0-16	0-20	0-35

Model Number (Cable)	PP6420-050-57	PP6420-070-57	PP6420-100-57	PP6420-200-57
Pressure Range (bar)	0-50	0-70	0-100	0-200

Model Number (Plug & Socket)	PP6420-050-67	PP6420-070-67	PP6420-100-67	PP6420-200-67
Pressure Range (bar)	0-50	0-70	0-100	0-200



Submersible Transducers and Transmitters

The submersible transducer and transmitter portfolio of TT Electronics is comprised of two families: the Trident Series Submersible Level-Depth Transmitter; and the Trident Series Corrosion Resistant Submersible Level/Depth Transmitter. Each has been designed for exceptional accuracy and reliability.

Trident Series Level/Depth Transmitters are a family of temperature compensated pressure transmitters. Their all-welded construction makes them ideal for even the most onerous of applications, including pump testing, reservoir, borehole, river and tank liquid level measurements.

Trident Series Corrosion Resistant Submersible Level/Depth Transmitters have been specifically designed for harsh environment liquid level monitoring requirements, including those of land fill and effluent sites. Their materials of construction ensure protection from even the most aggressive leachates in these applications.

Lightning and surge protection are also standard features of both product families, making them suitable for outdoor installations. They are also fully compensated over wide operational and compensated temperature ranges.

Trident Series Corrosion Resistant Submersible Level/Depth Transmitters REF: DS2801 & DS2802

Pressure Ranges	Available from 1 mWG to 500 mWG vented; Absolute available from 2.5 mWG
Power Supply	10 to 32 Vdc
Output Options	4-20 mA (two-wire)
Zero and Span Setting	±1 % of span
Non Linearity, Hysteresis & Repeatability (NLH)	<±0.25 % of span
Compensated Temp	0°C to 60°C
Operating Temp	-10°C to 60°C
Thermal Effects	Zero: <±0.015 % span/°C Span: <±0.015 % reading/°C typical
Safe Over-range	1.5 x rated range minimum
Burst Pressure	3 x rated range minimum
Long Term Stability	0.1 % span/12 months
EMC Protection	Meets EN2004/108/EC
Electrical Connection	PUR vented cable
Wetted Materials	DS2801: C316L stainless steel, alumina ceramic, polyurethane, acetal and Viton O-ring DS2802 (Enhanced Corrosion Resistance): DUPLEX stainless steel, alumina ceramic, polyurethane, acetal and chemraz O-ring



Trident Series Corrosion Resistant Submersible Level/Depth Transmitters

Model Number	PB-AIVAC-0001-A-G	PB-AIVAC-0001-B-G	PB-AIVAC-0001-C-G	PB-AIVAC-0001-D-G	PB-AIVAC-0001-E-G
Pressure Range (mbar)	0-100	0-100	0-100	0-100	0-100
Cable Length (m)	1	2	4	6	10

Model Number	PB-AIVAC-0004-A-G	PB-AIVAC-0004-B-G	PB-AIVAC-0004-C-G	PB-AIVAC-0004-D-G	PB-AIVAC-0004-E-G
Pressure Range (mbar)	0-400	0-400	0-400	0-400	0-400
Cable Length (m)	1	2	4	6	10

Model Number	PB-AIVAC-001-A-G	PB-AIVAC-001-B-G	PB-AIVAC-001-C-G	PB-AIVAC-001-D-G	PB-AIVAC-001-E-G
Pressure Range (bar)	0-1	0-1	0-1	0-1	0-1
Cable Length (m)	1	2	4	6	10

Model Number	PB-AIVAC-002-A-G	PB-AIVAC-002-B-G	PB-AIVAC-002-C-G	PB-AIVAC-002-D-G	PB-AIVAC-002-E-G
Pressure Range (bar)	0-2	0-2	0-2	0-2	0-2
Cable Length (m)	1	2	4	6	10

Model Number	PB-AIVAC-003-A-G	PB-AIVAC-003-B-G	PB-AIVAC-003-C-G	PB-AIVAC-003-D-G	PB-AIVAC-003-E-G
Pressure Range (bar)	0-3	0-3	0-3	0-3	0-3
Cable Length (m)	1	2	4	6	10

Model Number	PB-AIVAC-005-A-G	PB-AIVAC-005-B-G	PB-AIVAC-005-C-G	PB-AIVAC-005-D-G	PB-AIVAC-005-E-G
Pressure Range (bar)	0-5	0-5	0-5	0-5	0-5
Cable Length (m)	1	2	4	6	10

Model Number	PB-AIVAC-010-A-G	PB-AIVAC-010-B-G	PB-AIVAC-010-C-G	PB-AIVAC-010-D-G	PB-AIVAC-010-E-G
Pressure Range (bar)	0-10	0-10	0-10	0-10	0-10
Cable Length (m)	1	2	4	6	10



Oplek, Минск +375447584780 viber email: minsk7@td.by

Flowmeters

The flowmeters portfolio of TT Electronics provides high-accuracy liquid flow measurements of up to 100 m³/hr and gas flow up to 1000 m³/hr. We manufacture glass, plastic and metal flowmeters that are simple to install, use and maintain. A selection of products are available with ATEX approval.

Anaesthetic Tubes



Glass & Plastic Tube Variable Aperture Flow Meters



Metal Tube Variable Aperture Flow Meters



Anaesthetic GTF (Glass Tube & Float)

NGX, LGX, GU, PG/PGU

GMTB, GMT, GMTX

Gas Flow range	0.1 to 1.0L/min, 1.0 to 10L/min or 0.1 to 15L/min	5mL /min to 440L/min	0.5 - 1000m ³ /hr
Liquid flow range		2mL /min to 2400L/hr	20L/hr to 100m ³ /hr
Standard Gases	Oxygen, Air and Nitrous Oxide	Air	Air
Standard Fluids		Water	Water
Accuracy	±1.5% to ± 5% FSD	Up to ± 1.25% FSD to ± 5% FSD	± 2% FSD
Certification		ATE	IP65, CRN
Max Pressure	ATP, 1.013 Bar	10 to 25 bar	75 bar to 100 bar
Operating temperature	20°C	80 to 100 °C	-50 to 200°C
Materials of construction			
Float material	Duraluminium Red.	Duraluminium, Stainless Steel or PTFe	316 Stainless Steel or PVC
Tube Material	Borosilicate glass	Borosilicate glass, Polycarbonate and TPX plastic	Brass or 316 Stainless Steel
Tube Length	150 mm, 230 mm, 240 mm, 250 mm, & 260 mm	65 mm & 138 mm	15, 25, 50, 80 & 100 mm
Tube Diameter	Outside Diameter 12 mm or 15 mm nominal		
Scale Length		30-100 mm	100 mm
Frame Size		1 to 5	
Plate		Protective and non protective housing	Flanged or Screwed
Seals / O-ring		Brass , Stainless Steel, Viton or Nitrile	
Orifice Carrier			Polyester coated aluminium. Weatherproof coated to IP65
Power Supply / Relay Unit			4-20 mA output version
Transmitter			Mains or DC powered 4-20 mA transmitter
Alarm option		Available	Low & High, Single & Dual Channel
Process connection		Rear and inline versions	
Connection		G 1/4, G1, G 3/8 or G 1/2 female	DIN PN16+40, ANSI 150+300lb, BSPP female and NPT female
CUSTOMER OPTIONS	Individual flow calibration	Valve or non valved	ATEX approved, DC version only 85-265 Vac and 12-24 Vdc

All devices are available as analog indicators with or without alarms, as well as electronic transmitters with 4-20 mA and NAMUR contact outputs. Easy-to-read graphical displays are optional. Depending upon specified model, flow products can be used in all hazardous areas in flameproof, intrinsic safety or non sparking design. Custom options, such as special scales, are available for most products.

Shunts Orifice Flowmeters



PITOT Tube



Flostats Automatic Flow Controllers



SGUV, SGUL, LPCB Mark 1, LPCB Mark 2

Flo-Bar

MN, FV, Type B, Type LB

150 - 1250 dm ³ /min	5 - 100 000 cm ³ /min	
	2 - 3500 cm ³ /min	
± 2.5% to ± 5% at various test flows specified by LPCB	± 0.5% to ± 1%	
12 bar at 20°C, to 25 bar	5 bar	20 bar and 28 bar
80°C	90°C - 300°C	80°C to 100°C
Stainless Steel	Stainless Steel 316	
Borosilicate glass		Brass or 316 Stainless Steel
	13 mm, 25 mm and 60 mm	
Stainless Steel mounted		
Nitrile		Nitrile (Brass) or Viton (SS)
Polyester coated steel carrier ring		
Flanged or Vitealic	Optional	
Approved and Listed by LPCB		

Oplek, Минск +375447584780 viber email minsk17@tul.by

Temperature Instrumentation

TT Electronics manufactures a full range of thermocouples and temperature probes. They are available in both standard and custom designs, fully supported by our applications engineering team. We stock a full range of associated accessories and instrumentation and provide fast delivery for urgent requirements.

Thermocouples



- Ranges from +200°C to +1600°C
- All types and industries
- Materials & components held in stock
- In-house calibration and repair services
- Manufactured to the latest revision of AMS2750 for aerospace applications

Temperature Transmitters

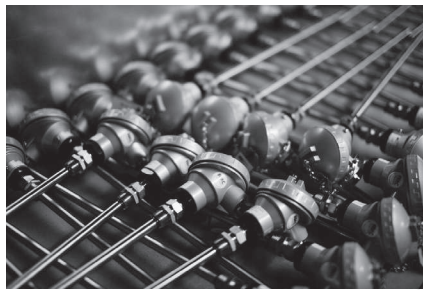

- Head or DIN rail mounted
- Configurable input/output
- In-head display and alarm relay options
- Intrinsically safe options
- Open HART® protocol

Refractory Sheaths and Cables



- Sheaths/tubes up to +1800°C
- Excellent corrosion resistance
- Range of materials
- Cables to suit all thermocouples
- Colour coded to IEC 584-3

Infrared Thermometers



- 0°C to +3000°C range
- Adjustable emissivity
- Datalogging function
- Fixed or portable versions
- Optional UKAS calibration

Controllers, Recorders and Dataloggers



- Process controllers and indicators
- Graphical recorders
- Stand alone or networked solutions
- SCADA & data acquisition packages
- Configuration and project management services

UKAS Calibration and Services

Located in Sheffield, United Kingdom, the accredited calibration laboratories of TT Electronics can provide either on-site or in-house calibration to either UKAS or traceable national standards under BS/EN/ISO17025 accredited procedures. Calibration services support temperature, pressure, flow and electrical measurement parameters. Certifications are issued using the latest technology. They support aerospace industry compliance to the latest revision of AMS2750. In addition, TT Electronics offers fast and efficient maintenance and repair services. Please consult the factory for details.

UKAS and Traceable Calibration

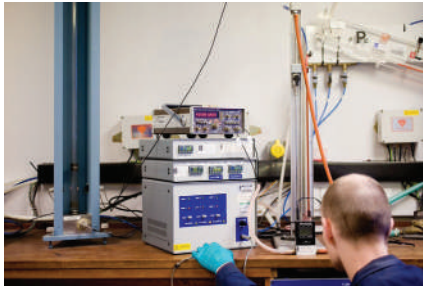

- Over 50 years of experience
- Flexibility to meet your requirements - on or off site
- Fast and efficient maintenance and repair services

Supported Measurement Parameters



- UKAS accredited for calibrations of Pressure, Temperature, Flow and Electrical instrumentation
- Temperature ranges from -196°C to +1600°C
- Gas flow ranges from 5 mL/min to 50 L/min
- Pressure ranges from 1 bar to 1200 bar
- Electrical – mV, mA, ohms and testing to the latest revision of AMS2750

Customer Care

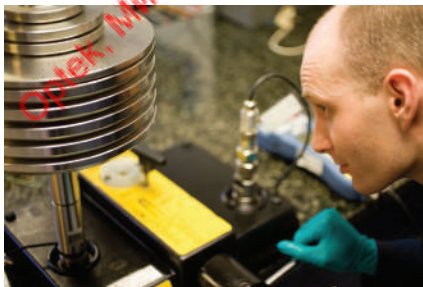

- Fast delivery for urgent requirements
- Customer collections service
- Full technical and application support for all products
- Comprehensive repair facility



Оптек, Минск +375447584780 viber email minsk17@tut.by

TT Electronics

Industrial Sensing and Control
1645 Wallace Drive, Suite 130
Dallas, TX 75006
USA

Toll Free: +1 800-341-4747
Tel: +1 972-323-220
Fax: +1 972 323 2396

Asia: asiasales@ttelectronics.com
Europe: emea@ttelectronics.com

www.ttelectronics.com

Optek, Минск +375447584780 viber email minsk17@tut.by
каталог, описание, технические, характеристики, datasheet, параметры, маркировка, габариты, фото, модуль, **Optek**,
даташит, Твёрдотельное реле, трехфазное, однофазное, датчик

КАТАЛОГ 2025г.

Optek в Беларуси

купить, продажа в **Минске, Беларусь**

электронные компоненты

[где и как купить в Минске?](#)



Продукция Optek

Категории: Энкодеры, Инклинометры, Управление и позиционирование, Тахометры, Счетчики, Обнаружение, движения и присутствия, Датчики измерения расстояния, Ограничитель, скорости, Тахогенераторы, Камеры, машинного, зрения, optek

Optek, Минск +375447584780 viber email minsk17@tut.by