

Pilz **Минск** т.+375447584780 Viber email [minsk17@tut.by](mailto:minsk17@tut.by)  
[www.fotorele.net](http://www.fotorele.net) [www.tiristor.by](http://www.tiristor.by) радиодетали, электронные компоненты  
tel.+375 29 758 47 80 МТС

[каталог](#), [описание](#), [технические](#), [характеристики](#), [datasheet](#), [параметры](#), [маркировка](#), [габариты](#), [фото](#), [даташит](#), [Pilz](#)

### [где и как купить в Минске?](#)

Сделать заявку или запрос можно по телефону или по электронной почте

Просим Вас указывать в заявке:

- название предприятия, факс, контактный телефон, контактное лицо;
- полное наименование и количество товара;
- возможность замены или аналоги;

## Каталог Pilz

Автоматизация

Сенсорные технологии

Реле

Компактные контроллеры

Контроллеры

Приводная техника

Сервисная робототехника

Сети

Управление и мониторинг

Программное обеспечение

Безопасные технологии управления

Система автоматизации PSS 4000

Модульная система защитных ограждений

Поиск изделий

Области применения

Мы создаем безопасные системы автоматизации.

Industrie 4.0

Отрасли промышленности

PNOZ s4.1 48-240VACDC 3 n/o 1 n/c

750154



Safety relay (standalone) Inputs: 1-/2-channel wiring with/without detection of shorts across contacts Outputs: 3 N/O, 1 N/C, 1 semiconductor UB 48 - 240 V AC/DC, width: 22.5 mm, plug-in terminals of screw type Monitoring E-STOP, safety gates.

## Технические характеристики

Согласования:	CE;cULus Listed;TÜV;CCC
Опции применения:	Мониторинг предохранительного шлюза;Мониторинг мгновенного E-STOP;Предельное реле;Мониторинг сменного модуля. Тип 4;Мониторинг сменного модуля. Тип 2 без тп;Мониторинг сменного модуля. Тип 2 с тп;Термошкаф
Режимы работы:	Один канал;Автоматический сброс;Двухканальный;Сброс вручную;Обнаружение КЗ на контактах;Тестирование запуска;Ручной сброс с мониторингом;без обнаружения КЗ на контактах;Самотестирование
Товарный стандарт:	EN 60947-5-1
Стандарты:	EN 50156-1;EN 60204-1;EN 62061;EN ISO 13849-1;VDE 0113-1;VDE 0116
Напряжение питания (V):	48,0 - 240,0
Тип питающего напряжения:	AC/DC
Тип клеммы:	Плагин
Тип клеммы:	Винтовая клемма
Мгновенные предохранительные контакты:	3
Предохр.контак. с задерж.на срабатывание:	0
Число дополнительных контактов:	1
Количество полупроводниковых выходов:	1
Категория останова:	0
Макс. ток на DC13 I (6 циклов/мин):	0.4 A
Макс. ток на AC15:	0.6 A

Размер по ширине:	22.5 mm
Размер по высоте:	98.0 mm
Размер по глубине:	120.0 mm
Вес брутто:	220 g
Вес нетто:	210 g
Окружающая температура:	-10 - 60 °C

## Дополнительные принадлежности



750004

PNOZ s Setscrew terminals 22,5mm



750900

PNOZ s pIE



750910

PNOZ s nIE



750010

PNOZ s terminator plug ( 10 pieces)



## Compact safety relays PNOZsigma

Application examples for project configuration -  
PNOZsigma product range

**pilz**  
more than automation  
safe automation

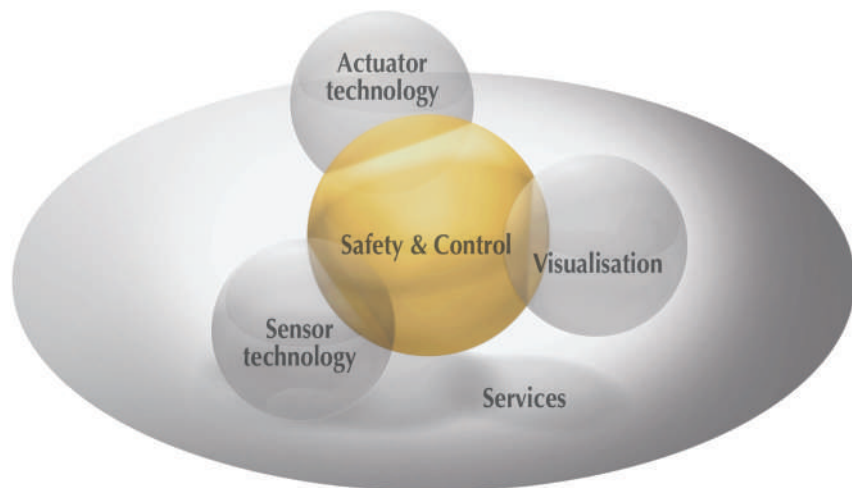

## Family-owned company with customer value

Pilz has a tradition as a family-run company stretching back over 50 years. Real proximity to customers is visible in all areas, instilling confidence through individual consultation, total flexibility and reliable service.

## Solution supplier for safety and standard

Solutions from Pilz protect man, machine and the environment. That's why all our competency goes into innovative individual products, system solutions that are well thought through plus appropriate services.

## Heading into the future together

Pilz rigorously pursues clearly defined goals, which at the same time represent the route to a successful future. Our focus is to complete our safe automation range and dovetail this core competency with the expansion of standard solutions.

You can find more details about Pilz and your products and services on the Internet:



► [www.pilz.com](http://www.pilz.com)

An overview of all available catalogues can be found at

► [www.pilz.com/catalogues](http://www.pilz.com/catalogues)

Technical support round the clock:



► +49 711 3409-444

## Exclusion of liability

The technical catalogue has been compiled with great care. It contains information about our company and our products. All statements are made in accordance with the current status of technology and to the best of our knowledge and belief. However, we cannot except liability for the accuracy and entirety of the information provided, except in the case of gross negligence. In particular it should be noted that statements do not have the legal quality of assurances or assured properties. We are grateful for any feedback on the contents.

September 2006

All rights to this publication are reserved by Pilz GmbH & Co. KG. We reserve the right to amend specifications without prior notice. Copies may be made for the user's internal purposes. The names of products, goods and technologies used in this manual are trademarks of the respective companies.

МІНІСТЕРСТВО НАЦІОНАЛЬНОЇ ЗАХИСТУ  
+375 29 544 7584780 viber zakaz@igbt.by

Application Examples	1.0
Emergency Stop Applications	1.1
Safety Gate Applications	1.2
ESPE Applications	1.3
Two-hand Applications	1.4
Standards And Directives	2.0
Standards And Directives	2.1
Service	3.0
Service	3.1

МИНСК +375447584780 viber zakaz@abt.by

МИНСК +375447584780 viber zakaz@igbt.by

Contents		Page
<b>Emergency stop applications</b>		
PNOZ s1	– Single-channel operation, contact expansion through contactor	Category 2* 1.1-2
PNOZ s2	– Single-channel operation, contact expansion through contactor	Category 2* 1.1-6
PNOZ s2	– Single-channel operation, contact expansion through PZE X4P	Category 2* 1.1-10
PNOZ s3	– Dual-channel operation, contact expansion through contactor	Category 3* 1.1-14
PNOZ s3	– Dual-channel operation, contact expansion through PZE X4.1P	Category 4* 1.1-18
PNOZ s4	– Dual-channel operation, contact expansion through contactor	Category 4* 1.1-22
PNOZ s5	– Safe standstill of one drive	Category 4* 1.1-26
PNOZ s5	– Safe standstill of two drives	Category 4* 1.1-30
PNOZ s5	– Combined with two PNOZ s7	Category 4* 1.1-34
PNOZ s7	– Combined with PNOZ s2	Category 2* 1.1-38
PNOZ s7	– Combined with PNOZ s4	Category 4* 1.1-42
PNOZ s8	– Combined with PNOZ s1	Category 2* 1.1-46
PNOZ s9	– Combined with PNOZ s4, safe standstill of one drive	Category 4* 1.1-50
PNOZ s10	– Combined with PNOZ s4	Category 4* 1.1-54

\* in accordance with EN 954-1

Минск +375447584780 [info@pilot.by](mailto:info@pilot.by)

## Category 2, EN 954-1

### PNOZ s1 - Single-channel operation, contact expansion through contactor

#### Features

- ▶ Single-channel operation
- ▶ Manual reset
- ▶ Contact expansion through positive-guided contactor
- ▶ Feedback circuit to monitor contact expansion
- ▶ Up to Category 2 of EN 954-1

#### Description

##### E-STOP function

When the E-STOP pushbutton S1 is operated, the supply voltage on the safety relay PNOZ s1 (K1) is interrupted, the safety contacts on K1 open. Contactor K2 de-energises.

##### Settings on the unit

- ▶ The terminator on the PNOZ s1 (K1) must be connected

##### Start/reset

The safety relay PNOZ s1 (K1) can be started by pressing reset button S2 if:

- ▶ E-STOP pushbutton S1 has not been operated and
- ▶ Contactor K2 has de-energised.

#### Feedback loop

The positive-guided N/C contact on contactor K2 is monitored in feedback loop A1-S34 of safety relay PNOZ s1 (K1).

#### Safety assessment

- ▶ Earth fault in the input circuit is detected.
- ▶ A fault on the device does not lead to the loss of the safety function.
- ▶ The safety relay PNOZ s1 (K1) can be started when the input circuit (supply voltage) at K1 is closed first, followed by the reset button S2. This avoids an unwanted reset before the input circuit is closed or as a result of the reset button being overridden.
- ▶ The safety relay PNOZ s1 (K1) is tested in each on/off cycle. The E-STOP pushbutton S1 must be operated at appropriate intervals to perform a function test. This must be recorded in the machine's operating manual (organisational measure). An E-STOP is not a primary safety measure, just a precautionary measure for emergencies (EN ISO 12100-2). A start-up test is therefore not required. As the PNOZ s1 cannot be tested automatically, a second shutdown route is required (e.g. via a main switch or a master contactor).

#### Pilz products

Number	Designation	Order number
1	PNOZ s1	750 101
1	PIT es1.11	400 100
1	PIT esb1.1	400 305

## Category 2, EN 954-1

### PNOZ s1 - Single-channel operation, contact expansion through contactor

#### Safety-related characteristics in accordance with EN ISO 13849-1: 2006

- |  |  |
|--|--|
| ▶ Safety function:   | Shut down machine via E-STOP   |
| ▶ Safety-related parts of the control system (SRP/CS):         | Input device (E-STOP button), logic (PNOZ s1), actuator (contactor K2)   |
| ▶ Performance level:   | <b>PL c</b>  |
| ▶ PL information only applies under the following conditions*: |  |
| - Common cause failure (CCF):                                  | Requirements are considered to be met (must be tested on implementation) |
| - Proof test interval:   | 20 years   |
| - Operating interval (electromechanical components):           | One operation per week for input device and actuator                     |
| - Contactor K2 - characteristic data:                          | B10 <sub>d</sub> : 2,000,000; dangerous failure rate: 65 %               |

\* Further requirements of EN ISO 13849-1 have also to be met (e.g. requirements for avoiding systematic faults, among others).

МІНСК +375447584780 viber zakaz@igt.by

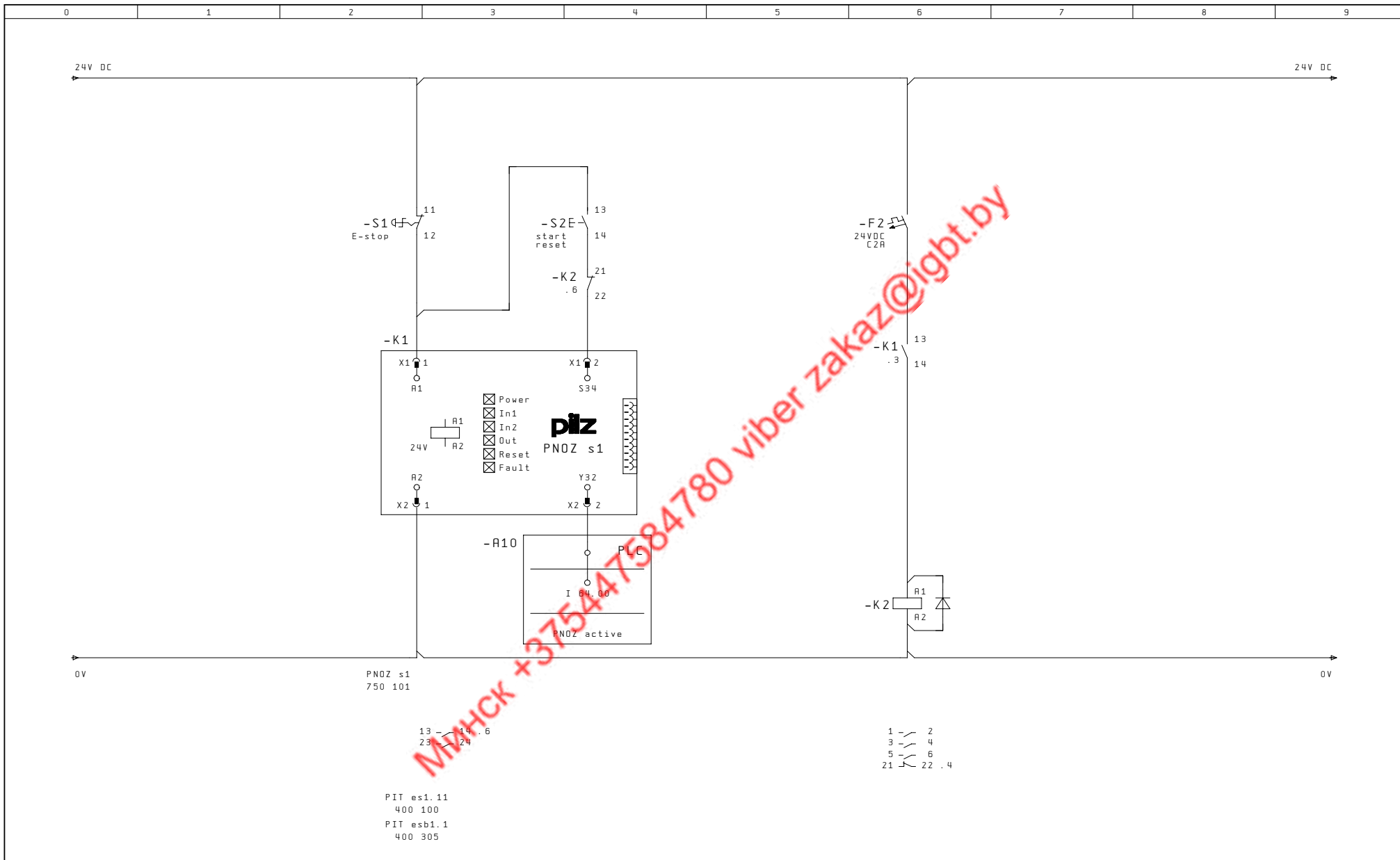

Revision	20.03.06	Date	07.12.05	Emergency stop application	Pilz GmbH & Co. KG Felix-Wankel-Str. 2 73760 Ostfildern	Emergency stop, extension contact by contactor and manual start	Directory:
Name	WED	Name	WED				.. PNOZ\05PIL013
		Dep.	CS	Category 2 EN 954-1			PNOZs1
							Page: 1

МИНСК +375447584780 viber zakaz@igbt.by

## Category 2, EN 954-1

### PNOZ s2 – Single-channel operation, contact expansion through contactor

#### Features

- ▶ Single-channel operation
- ▶ Monitored reset with rising edge
- ▶ Contact expansion through positive-guided contactor
- ▶ Feedback circuit to monitor contact expansion
- ▶ Up to Category 2 of EN 954-1

#### Description

##### E-STOP function

When the E-STOP pushbutton S1 is operated, the supply voltage on the safety relay PNOZ s2 (K1) is interrupted, the safety contacts on K1 open. Contactor K2 de-energises.

##### Settings on the unit

- ▶ The terminator on the PNOZ s2 (K1) must be connected.
- ▶ The operating mode selector switch (mode) on the safety relay PNOZ s2 (K1) must be set to “Monitored reset, rising edge”.

##### Start/reset

The safety relay PNOZ s2 (K1) can be started by pressing reset button S2 if:

- ▶ E-STOP pushbutton S1 has not been operated and
- ▶ Contactor K2 has de-energised.

##### Feedback loop

The positive-guided N/C contact on contactor K2 is monitored in feedback loop A1-S34 of safety relay PNOZ s2 (K1).

##### Safety assessment

- ▶ Earth fault in the input circuit is detected.
- ▶ A fault on the device does not lead to the loss of the safety function.
- ▶ The safety relay PNOZ s2 (K1) can be started when the input circuit (supply voltage) at K1 is closed first, followed by the reset button S2. This avoids an unwanted reset before the input circuit is closed or as a result of the reset button being overridden.
- ▶ The safety relay PNOZ s2 (K1) is tested in each on/off cycle. The E-STOP pushbutton S1 must be operated at appropriate intervals to perform a function test. This must be recorded in the machine's operating manual (organisational measure). An E-STOP is not a primary safety measure, just a precautionary measure for emergencies (EN ISO 12100-2). A start-up test is therefore not required. As the PNOZ s2 cannot be tested automatically, a second shutdown route is required (e.g. via a main switch or a master contactor).

- ▶ If the position of the operating mode selector switch (mode) is changed during operation, an error message will be triggered; the safety contacts on K1 open. This fault condition can only be rectified by switching the supply voltage on the safety relay PNOZ s2 (K1) off and then on again.

##### Pilz products

Number	Designation	Order number
1	PNOZ s2	750 102
1	PIT es1.11	400 100
1	PIT esb1.1	400 305

## Category 2, EN 954-1

### PNOZ s2 – Single-channel operation, contact expansion through contactor

#### Safety-related characteristics in accordance with EN ISO 13849-1: 2006

- |  |  |
|--|--|
| ▶ Safety function:   | Shut down machine via E-STOP   |
| ▶ Safety-related parts of the control system (SRP/CS):         | Input device (E-STOP button), logic (PNOZ s2), actuator (contactor K2)   |
| ▶ Performance level:   | <b>PL c</b>  |
| ▶ PL information only applies under the following conditions*: |  |
| - Common cause failure (CCF):                                  | Requirements are considered to be met (must be tested on implementation) |
| - Proof test interval:   | 20 years   |
| - Operating interval (electromechanical components):           | One operation per week for input device and actuator                     |
| - Contactor K2 - characteristic data:                          | B10 <sub>d</sub> : 2,000,000; dangerous failure rate: 65 %               |

\* Further requirements of EN ISO 13849-1 have also to be met (e.g. requirements for avoiding systematic faults, among others).

Минск +375447584780 viber zakaz@igt.by

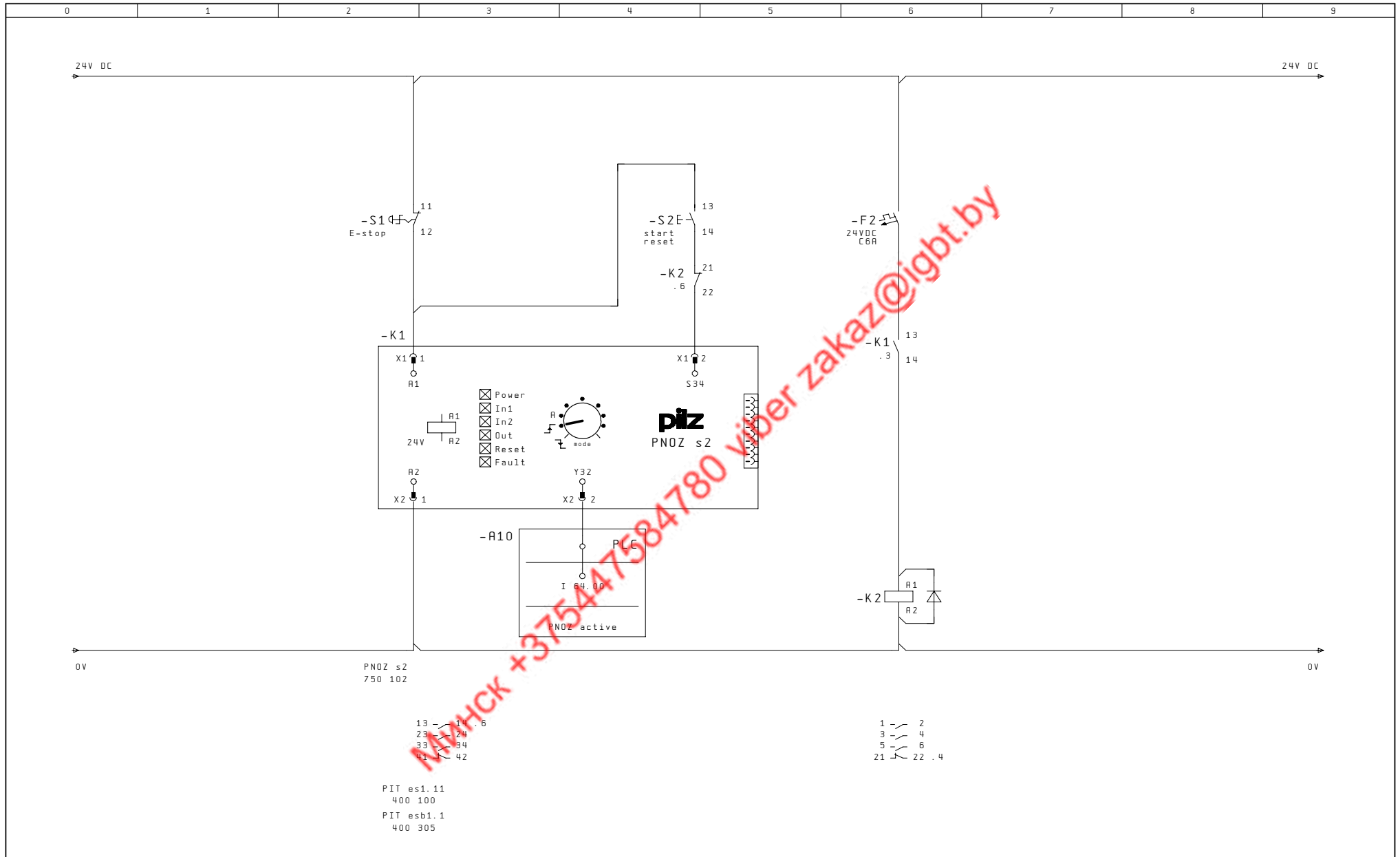

Revision	08.03.06	Date	07.12.05	Emergency stop application	<b>pilz</b> Pilz GmbH & Co. KG Felix-Wankel-Str. 2 73760 Ostfildern	Emergency stop, extension contact by contactor and monitored start	Directory:
Name	WED	Name	WED				.. PNOZ\05PIL013
		Dep.	CS	Category 2 EN 954-1			PNOZs2
							Page: 1

МИНСК +375447584780 viber zakaz@igbt.by

## Category 2, EN 954-1

### PNOZ s2 - Single-channel operation, contact expansion through PZE X4P

#### Features

- ▶ Single-channel operation
- ▶ Monitored reset with rising edge
- ▶ Contact expansion through PZE X4P (contact expander module)
- ▶ Feedback circuit to monitor contact expansion
- ▶ Up to Category 2 of EN 954-1

#### Description

##### E-STOP function

When the E-STOP pushbutton S3 is operated, the supply voltage on the safety relay PNOZ s2 (K3) is interrupted, the safety contacts on K3 open. As a result the supply voltage to the contact expander module PZE X4VP (K4) is interrupted, the safety contacts on K4 open.

##### Settings on the unit

- ▶ The terminator on the PNOZ s2 (K3) must be connected.
- ▶ The operating mode selector switch (mode) on the safety relay PNOZ s2 (K3) must be set to "Monitored reset, rising edge".

##### Start/reset

The safety relay PNOZ s2 (K3) can be started by pressing reset button S4 if:

- ▶ E-STOP pushbutton S3 has not been operated and
- ▶ Feedback loop Y1/Y2 on contact expander module PZE X4P (K4) is closed.

##### Feedback loop

The feedback loop on the safety relay PNOZ s2 (K3) is connected to the feedback loop on the contact expander module PZE X4P (K4).

##### Safety assessment

- ▶ Earth fault in the input circuit is detected.
- ▶ A fault on the device does not lead to the loss of the safety function.
- ▶ The safety relay PNOZ s2 (K3) can be started when the input circuit (supply voltage) at K3 is closed first, followed by the reset button S4. This avoids an unwanted reset before the input circuit is closed or as a result of the reset button being overridden.
- ▶ The safety relay PNOZ s2 (K3) is tested in each on/off cycle. The E-STOP pushbutton S3 must be operated at appropriate intervals to perform a function test. This must be recorded in the machine's operating manual (organisational measure). An E-STOP is not a primary safety measure, just a precautionary measure for emergencies (EN ISO 12100-2). A start-up test is therefore not required.  
As the PNOZ s2 cannot be tested

- automatically, a second shutdown route is required (e.g. via a main switch or a master contactor).
- ▶ If the position of the operating mode selector switch (mode) is changed during operation, an error message will be triggered; the safety contacts on K3 open. This fault condition can only be rectified by switching the supply voltage on the safety relay PNOZ s2 (K3) off and then on again.

#### Pilz products

Number	Designation	Order number
1	PNOZ s2	750 102
1	PZE X4P	777 585
1	PIT es1.11	400 100
1	PIT esb1.1	400 305

## Category 2, EN 954-1

### PNOZ s2 - Single-channel operation, contact expansion through PZE X4P

#### Safety-related characteristics in accordance with EN 62061: 2005

- ▶ Safety-related control function (SRCF): Shut down machine via E-STOP
- ▶ Subsystems: Input device (E-STOP button), logic (PNOZ s2), actuator (PZE X4P)
- ▶ Safety integrity level: **SIL 1**
- ▶ SIL information only applies under the following conditions\*:
  - Common cause failure (CCF):  $\beta = 10 \%$
  - Proof test interval: 20 years
  - Operating interval (electromechanical components): One operation per week for input device

#### Safety-related characteristics in accordance with EN ISO 13849-1: 2006

- ▶ Safety function: Shut down machine via E-STOP
- ▶ Safety-related parts of the control system (SRP/CS): Input device (E-STOP button), logic (PNOZ s2), actuator (PZE X4P)
- ▶ Performance level: **PL c**
- ▶ PL information only applies under the following conditions\*:
  - Common cause failure (CCF): Requirements are considered to be met (must be tested on implementation)
  - Proof test interval: 20 years
  - Operating interval (electromechanical components): One operation per week for input device

\* Further requirements of EN 62061 and EN ISO 13849-1 have also to be met (e.g. requirements for systematic safety integrity and avoiding systematic faults, among others).

Минск +375447584780 viber zakaz@igt.by

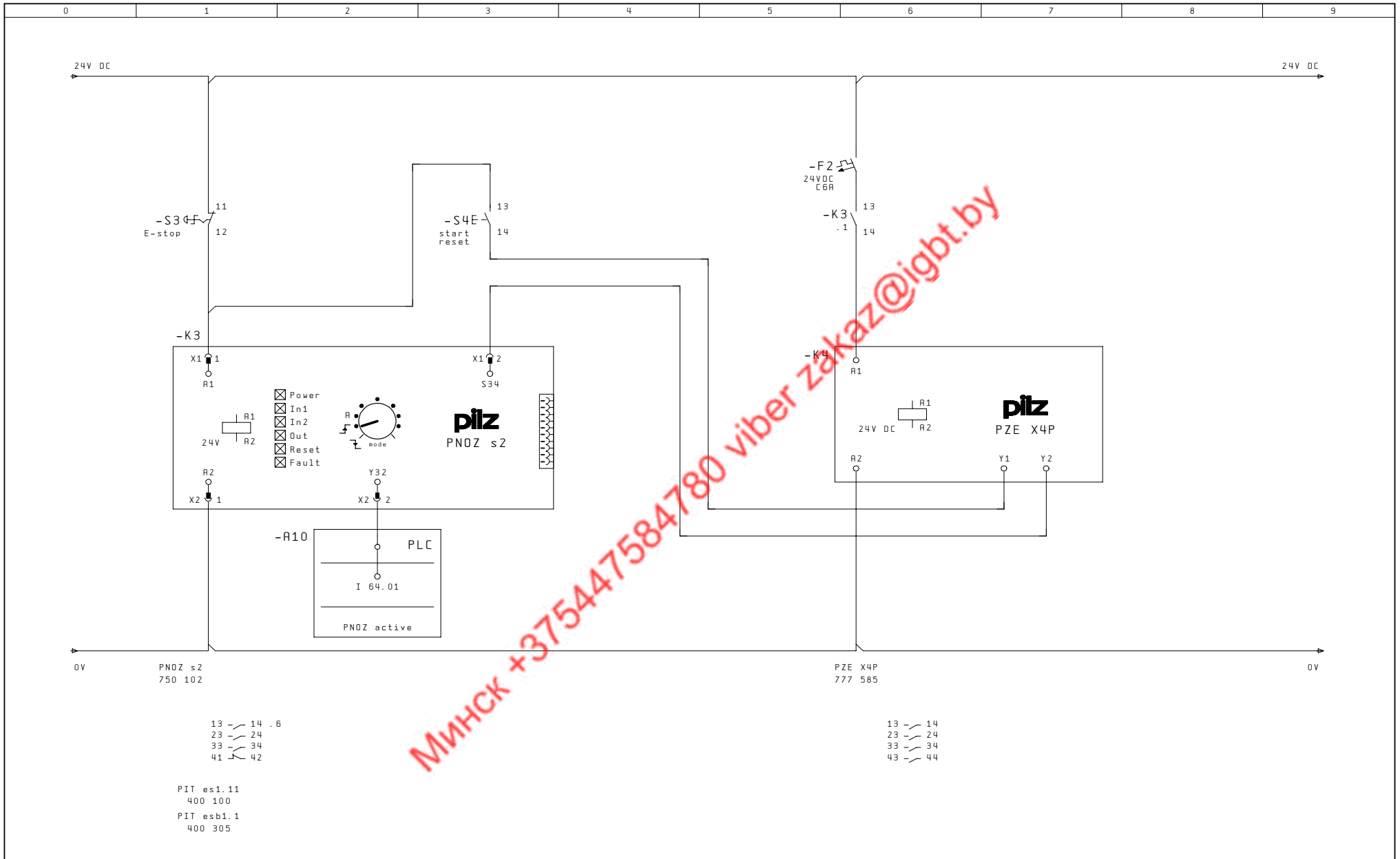

Revision	08.03.06	Date	07.12.05	Emergency stop application	Pilz GmbH & Co. KG Felix-Wankel-Str. 2 73760 Ostfildern	Emergency stop, extension contact by PZE X4P and monitored start	Directory:
Name	WED	Name	WED				.. PNOZ\05PIL013
		Dep.	CS	Category 2 EN 954-1			PNOZs2
							Page: 2

МИНСК +375447584780 viber zakaz@igbt.by

## Category 3, EN 954-1

### PNOZ s3 - Dual-channel operation, contact expansion through contactor

#### Features

- ▶ Dual-channel operation
- ▶ Monitored reset with rising edge
- ▶ Contact expansion through positive-guided contactors
- ▶ Feedback loop to monitor contact expansion
- ▶ Up to Category 3 of EN 954-1

#### Description

##### E-STOP function

When the E-STOP pushbutton S1 is operated, the input circuit on the safety relay PNOZ s3 (K1) is interrupted, the safety contacts on K1 open. Contactors KM1 and KM2 de-energise.

##### Settings on the unit

- ▶ The terminator on the PNOZ s3 (K1) must be connected.
- ▶ The operating mode selector switch (mode) on the safety relay PNOZ s3 (K1) must be set to "Monitored reset, rising edge without detection of shorts across contacts (ln2+)".

##### Start/reset

The safety relay PNOZ s3 (K1) can be started by pressing reset button S2 if:

- ▶ E-STOP pushbutton S1 has not been operated and
- ▶ Contactors KM1 and KM2 have de-energised.

##### Feedback loop

The positive-guided N/C contacts on contactors KM1 and KM2 are monitored in feedback loop S12-S34 of safety relay PNOZ s3 (K1).

##### Safety assessment

- ▶ Earth fault in the input circuit is detected.
- ▶ A fault on the device does not lead to the loss of the safety function.
- ▶ The safety relay PNOZ s3 (K1) can be started when the input circuit at K1 is closed first, followed by reset button S2. This avoids an unwanted reset before the input circuit is closed or as a result of the reset button being overridden.
- ▶ If the position of the operating mode selector switch (mode) is changed during operation, an error message will be triggered; the safety contacts on K1 open. This fault condition can only be rectified by switching the supply voltage on the safety relay PNOZ s3 (K1) off and then on again.

#### Pilz products

Number	Designation	Order number
1	PNOZ s3	750 103
1	PITestop Set1	400 410

## Category 3, EN 954-1

### PNOZ s3 - Dual-channel operation, contact expansion through contactor

#### Safety-related characteristics in accordance with EN 62061: 2005

- ▶ Safety-related control function (SRCF): Shut down machine via E-STOP
- ▶ Subsystems: Input device (E-STOP button), logic (PNOZ s3), actuator (contactors KM1 and KM2)
- ▶ Safety integrity level: **SIL 2**
- ▶ SIL information only applies under the following conditions\*:
  - Common cause failure (CCF):  $\beta = 10 \%$
  - Proof test interval: 20 years
  - Operating interval (electromechanical components): One operation per week for input device and actuator
  - Contactors KM1/KM2 - characteristic data:  $B10_d: 2,000,000$ ; dangerous failure rate: 65 %

#### Safety-related characteristics in accordance with EN ISO 13849-1: 2006

- ▶ Safety function: Shut down machine via E-STOP
- ▶ Safety-related parts of the control system (SRP/CS): Input device (E-STOP button), logic (PNOZ s3), actuator (contactors KM1 and KM2)
- ▶ Performance level: **PL d**
- ▶ PL information only applies under the following conditions\*:
  - Common cause failure (CCF): Requirements are considered to be met (must be tested on implementation)
  - Proof test interval: 20 years
  - Operating interval (electromechanical components): One operation per week for input device and actuator
  - Contactors KM1/KM2 - characteristic data:  $B10_d: 2,000,000$ ; dangerous failure rate: 65 %

\* Further requirements of EN 62061 and EN ISO 13849-1 have also to be met (e.g. requirements for systematic safety integrity and avoiding systematic faults, among others).

Мінск +375447584780 viber zakaz@igt.by

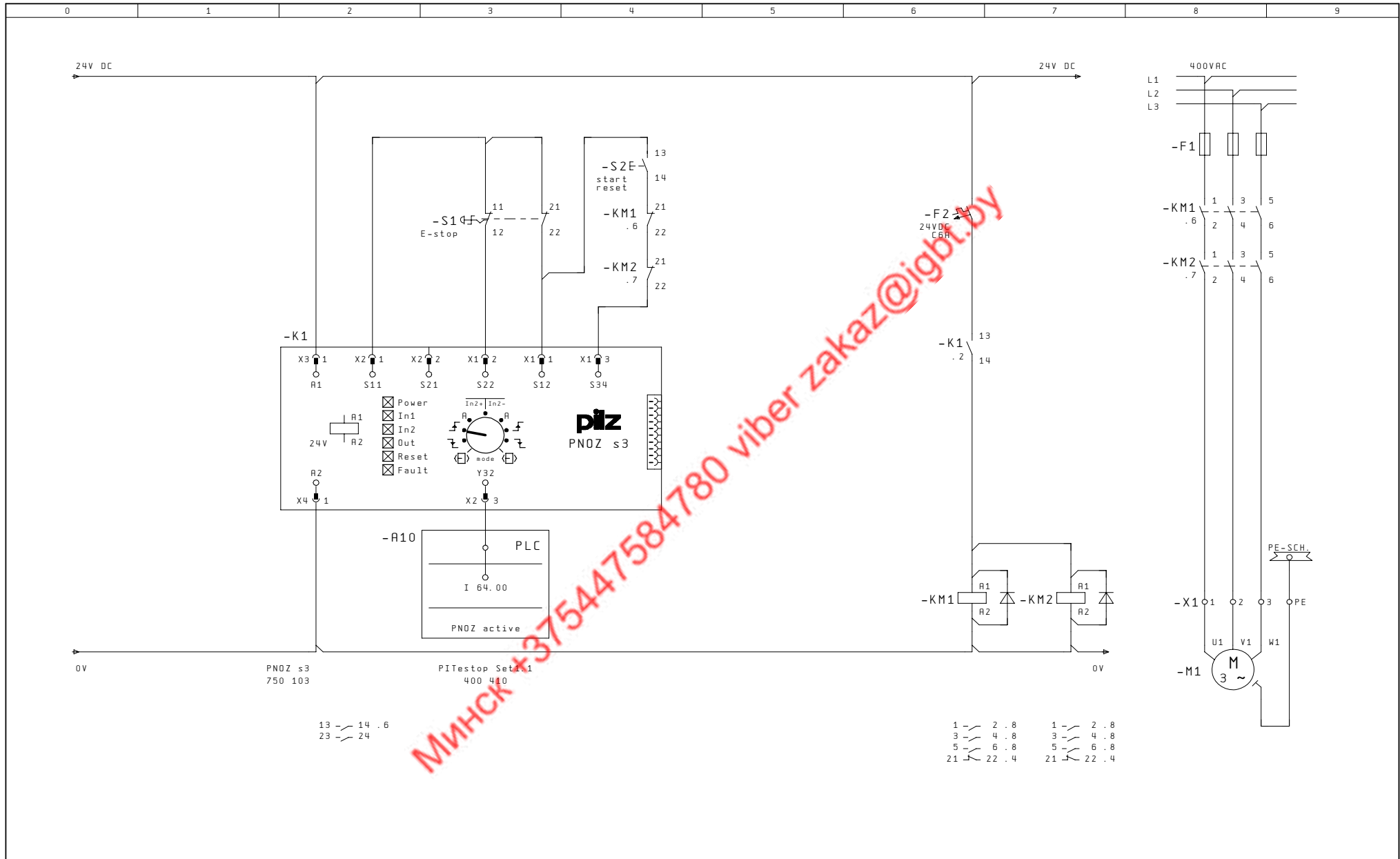

МИНСК +375447584780 viber zakaz@igbt.by

Revision	08.03.06	Date	07.12.05	Emergency stop application	<b>pilz</b> Pilz GmbH & Co. KG Felix-Wankel-Str. 2 73760 Ostfildern	Emergency stop, extension contact by contactor and monitored start	Directory:
Name	WED	Name	WED				.. PNOZ\05PIL013
		Dep.	CS	Category 3 EN 954-1			PNOZs3
							Page: 1

МИНСК +375447584780 viber zakaz@igbt.by

## Category 4, EN 954-1

### PNOZ s3 - Dual-channel operation, contact expansion through PZE X4.1P

#### Features

- ▶ Dual-channel operation with detection of shorts across contacts
- ▶ Monitored reset with rising edge
- ▶ Contact expansion through PZE X4.1P (contact expander module)
- ▶ Feedback loop to monitor contact expansion
- ▶ Up to Category 4 of EN 954-1

#### Description

##### E-STOP function

When the E-STOP pushbutton S5 is operated, the input circuit on the safety relay PNOZ s3 (K5) is interrupted, the safety contacts on K5 open. As a result the input circuit on the contact expander module PZE X4.1P (K6) is interrupted, the safety contacts on K6 open.

##### Settings on the unit

- ▶ The terminator on the PNOZ s3 (K5) must be connected.
- ▶ The operating mode selector switch (mode) on the safety relay PNOZ s3 (K5) must be set to "Monitored reset, rising edge with detection of shorts across contacts (In2-)".

#### Start/reset

The safety relay PNOZ s3 (K5) can be started by pressing reset button S6 if:

- ▶ E-STOP pushbutton S5 has not been operated and
- ▶ Feedback loop Y1/Y2 on contact expander module PZE X4.1P (K6) is closed.

#### Feedback loop

The feedback loop on the safety relay PNOZ s3 (K5) is connected to the feedback loop on the contact expander module PZE X4.1P (K6).

#### Safety assessment

- ▶ Earth faults and shorts between contacts in the input circuit are detected.
- ▶ A fault on the device does not lead to the loss of the safety function.
- ▶ The safety relay PNOZ s3 (K5) can be started when the input circuit at K5 is closed first, followed by reset button S6. This avoids an unwanted reset before the input circuit is closed or as a result of the reset button being overridden.
- ▶ If the position of the operating mode selector switch (mode) is changed during operation, an error message will be triggered; the safety contacts on K5 open. This fault condition can only be rectified by switching the supply voltage on the safety relay PNOZ s3 (K5) off and then on again.

#### Pilz products

Number	Designation	Order number
1	PNOZ s3	750 103
1	PZE X4.1P	777 587
1	PI Testop Set 1.1	400 410

## Category 4, EN 954-1

### PNOZ s3 - Dual-channel operation, contact expansion through PZE X4.1P

#### Safety-related characteristics in accordance with EN 62061: 2005

- ▶ Safety-related control function (SRCF): Shut down machine via E-STOP
- ▶ Subsystems: Input device (E-STOP button), logic (PNOZ s3), actuator (PZE X4.1P)
- ▶ Safety integrity level: **SIL 3**
- ▶ SIL information only applies under the following conditions\*:
  - Common cause failure (CCF):  $\beta = 10 \%$
  - Proof test interval: 20 years
  - Operating interval (electromechanical components): One operation per week for input device

#### Safety-related characteristics in accordance with EN ISO 13849-1: 2006

- ▶ Safety function: Shut down machine via E-STOP
- ▶ Safety-related parts of the control system (SRP/CS): Input device (E-STOP button), logic (PNOZ s3), actuator (PZE X4.1P)
- ▶ Performance level: **PL e**
- ▶ PL information only applies under the following conditions\*:
  - Common cause failure (CCF): Requirements are considered to be met (must be tested on implementation)
  - Proof test interval: 20 years
  - Operating interval (electromechanical components): One operation per week for input device

\* Further requirements of EN 62061 and EN ISO 13849-1 have also to be met (e.g. requirements for systematic safety integrity and avoiding systematic faults, among others).

Минск +375447584780 viber zakaz@igub.by

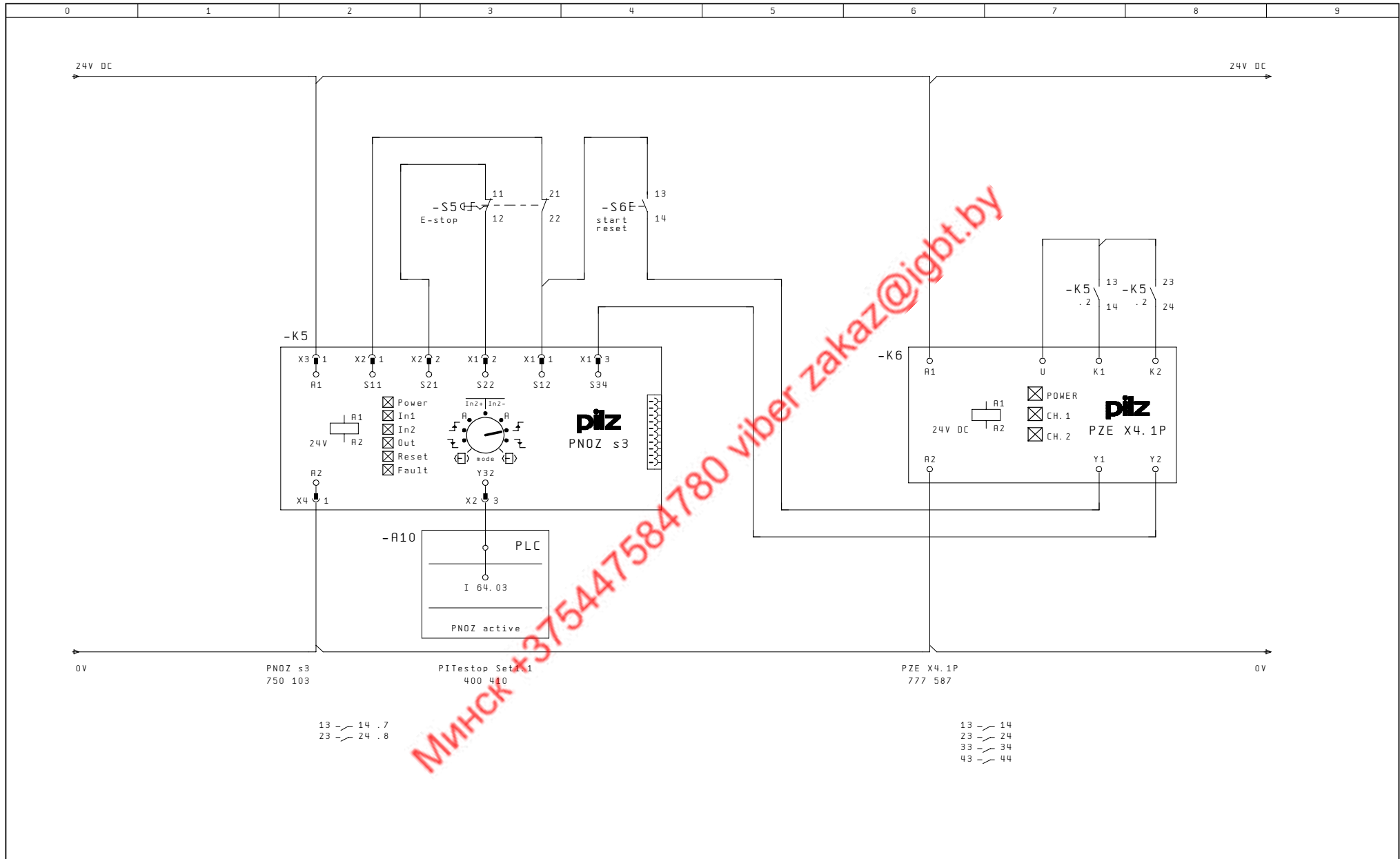

Revision	08.03.06	Date	07.12.05	Emergency stop application	<b>PIIZ</b> Pilz GmbH & Co. KG Felix-Wankel-Str. 2 73760 Ostfildern	Emergency stop, extension contact by PZE X4.1P and monitored start	Directory:
Name	WED	Name	WED				.. PNOZ\05PIL013
		Dep.	CS	Category 4 EN 954-1			PNOZs3
							Page: 3

МИНСК +375447584780 viber zakaz@igbt.by

## Category 4, EN 954-1

### PNOZ s4 - Dual-channel operation, contact expansion through contactor

#### Features

- ▶ Dual-channel operation with detection of shorts across contacts
- ▶ Monitored reset with rising edge
- ▶ Contact expansion through positive-guided contactors
- ▶ Feedback loop to monitor contact expansion
- ▶ Up to Category 4 of EN 954-1

#### Description

##### E-STOP function

When the E-STOP pushbutton S1 is operated, the input circuit on the safety relay PNOZ s4 (K1) is interrupted, the safety contacts on K1 open. Contactors KM1 and KM2 de-energise.

##### Settings on the unit

- ▶ The terminator on the PNOZ s4 (K1) must be connected.
- ▶ The operating mode selector switch (mode) on the safety relay PNOZ s4 (K1) must be set to "Monitored reset, rising edge with detection of shorts across contacts (In2-)".

##### Start/reset

The safety relay PNOZ s4 (K1) can be started by pressing reset button S2 if:

- ▶ E-STOP pushbutton S1 has not been operated and
- ▶ Contactors KM1 and KM2 have de-energised.

##### Feedback loop

The positive-guided N/C contacts on contactors KM1 and KM2 are monitored in feedback loop S12-S34 of safety relay PNOZ s4 (K1).

##### Safety assessment

- ▶ The safety relay PNOZ s4 (K1) and contactors KM1 and KM2 must be installed in a single mounting area (control cabinet) in order to exclude a short across the output.
- ▶ Earth faults and shorts between contacts in the input circuit are detected.
- ▶ A fault on the device does not lead to the loss of the safety function.
- ▶ The safety relay PNOZ s4 (K1) can be started when the input circuit at K1 is closed first, followed by reset button S2. This avoids an unwanted reset before the input circuit is closed or as a result of the reset button being overridden.
- ▶ If the position of the operating mode selector switch (mode) is changed during operation, an error message will be

triggered; the safety contacts on K1 open. This fault condition can only be rectified by switching the supply voltage on the safety relay PNOZ s4 (K1) off and then on again.

#### Pilz products

Number	Designation	Order number
1	PNOZ s4	750 104
1	PITestop Set1.1	400 410

## Category 4, EN 954-1

### PNOZ s4 - Dual-channel operation, contact expansion through contactor

#### Safety-related characteristics in accordance with EN 62061: 2005

- ▶ Safety-related control function (SRCF): Shut down machine via E-STOP
- ▶ Subsystems: Input device (E-STOP button), logic (PNOZ s4), actuator (contactors KM1 and KM2)
- ▶ Safety integrity level: **SIL 3**
- ▶ SIL information only applies under the following conditions\*:
  - Common cause failure (CCF):  $\beta = 10 \%$
  - Proof test interval: 20 years
  - Operating interval (electromechanical components): One operation per week for input device and actuator
  - Contactors KM1/KM2 - characteristic data:  $B10_d: 2,000,000$ ; dangerous failure rate: 65 %

#### Safety-related characteristics in accordance with EN ISO 13849-1: 2006

- ▶ Safety function: Shut down machine via E-STOP
- ▶ Safety-related parts of the control system (SRP/CS): Input device (E-STOP button), logic (PNOZ s4), actuator (contactors KM1 and KM2)
- ▶ Performance level: **PL e**
- ▶ PL information only applies under the following conditions\*:
  - Common cause failure (CCF): Requirements are considered to be met (must be tested on implementation)
  - Proof test interval: 20 years
  - Operating interval (electromechanical components): One operation per week for input device and actuator
  - Contactors KM1/KM2 - characteristic data:  $B10_d: 2,000,000$ ; dangerous failure rate: 65 %

\* Further requirements of EN 62061 and EN ISO 13849-1 have also to be met (e.g. requirements for systematic safety integrity and avoiding systematic faults, among others).

Мінск +375447584780 viber zakaz@igt.by

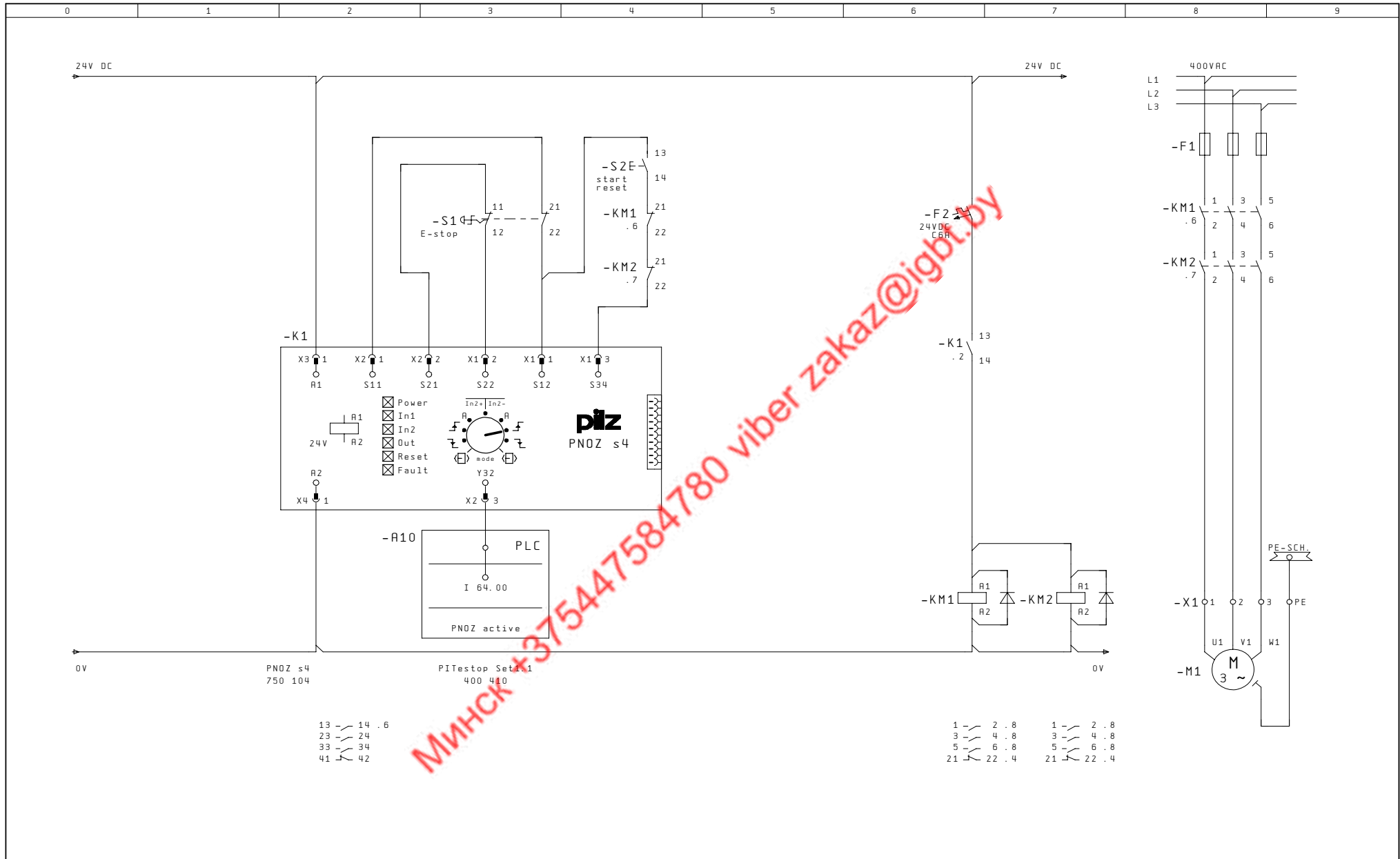

Revision	08.03.06	Date	07.12.05	Emergency stop application	 Pilz GmbH & Co. KG Felix-Wankel-Str. 2 73760 Ostfildern	Emergency stop, extension contact by contactor and monitored start	Directory:
Name	WED	Name	WED				.. PNOZ\05PIL013
		Dep.	CS	Category 4 EN 954-1			PNOZs4
							Page: 1

МИНСК +375447584780 viber zakaz@igbt.by

## Category 4, EN 954-1

### PNOZ s5 - Safe standstill of one drive

#### Features

- ▶ Dual-channel operation with detection of shorts across contacts
- ▶ Monitored reset with rising edge
- ▶ Safe standstill of one drive after E-STOP
- ▶ Contact expansion through positive-guided contactors
- ▶ Feedback loop to monitor contact expansion
- ▶ Up to Category 4 of EN 954-1
- ▶ Stop category 1 in accordance with EN 60204-1

#### Description

##### E-STOP function

When the E-STOP pushbutton S1 is operated, both the drive and the supply to the drive are shut down after a delay time. When the E-STOP pushbutton S1 is operated, the input circuit on the safety relay PNOZ s5 (K1) is interrupted, safety contact 13-14 on K1 opens immediately and triggers a “fast stop” at the drive controller A1.

The delay-on de-energisation safety contact 37-38 switches off contactors KM1 and KM2 after a delay. In this way, the drive controller A1 is isolated from the energy supply (mains) after a delay. The delay-on de-energisation time is set on the safety relay PNOZ s5 (K1).

#### Settings on the unit

- ▶ The terminator on the PNOZ s5 (K1) must be connected.
- ▶ The operating mode selector switch (mode) on the safety relay PNOZ s5 (K1) must be set to “Monitored reset, rising edge with detection of shorts across contacts (In2-)”.
- ▶ The delay time on the safety relay PNOZ s5 (K1) is set using the time selector switch t[s] and the factor selector switch n.

#### Start/reset

The safety relay PNOZ s5 (K1) can be started by pressing reset button S2 if:

- ▶ E-STOP pushbutton S1 has not been operated and
- ▶ Contactors KM1 and KM2 have de-energised.

#### Feedback loop

The positive-guided N/C contacts on contactors KM1 and KM2 are monitored in feedback loop S12-S34 of safety relay PNOZ s5 (K1).

#### Safety assessment

- ▶ The safety relay (K1) and contactors KM1 and KM2 must be installed in a single mounting area (control cabinet) in order to exclude a short across the output.
- ▶ Earth faults and shorts between contacts in the input circuit are detected.

- ▶ A fault on the device does not lead to the loss of the safety function.
- ▶ The safety relay PNOZ s5 (K1) can be started when the input circuit at K1 is closed first, followed by reset button S2. This avoids an unwanted reset before the input circuit is closed or as a result of the reset button being overridden.
- ▶ The delay time set for the safety relay PNOZ s5 (K1) must be longer than the maximum braking time on the drive regulator A1.
- ▶ The time delay must not be able to cause an additional hazard.
- ▶ If the position of the operating mode selector switch (mode) or the rotary switch for the time setting is changed during operation, an error message will be triggered; the safety contacts on K1 open. This fault condition can only be rectified by switching the supply voltage on the safety relay PNOZ s5 (K1) off and then on again.

#### Pilz products

Number	Designation	Order number
1	PNOZ s5	750 105
1	PITestop Set1.1	400 410

## Category 4, EN 954-1

### PNOZ s5 - Safe standstill of one drive

#### Safety-related characteristics in accordance with EN 62061: 2005

- ▶ Safety-related control function (SRCF): Shut down machine via E-STOP
- ▶ Subsystems: Input device (E-STOP button), logic (PNOZ s5), actuator (contactors KM1 and KM2)
- ▶ Safety integrity level: **SIL 3**
- ▶ SIL information only applies under the following conditions\*:
  - Common cause failure (CCF):  $\beta = 10 \%$
  - Proof test interval: 20 years
  - Operating interval (electromechanical components): One operation per week for input device and actuator
  - Contactors KM1/KM2 - characteristic data:  $B10_d: 2,000,000$ ; dangerous failure rate: 65 %

#### Safety-related characteristics in accordance with EN ISO 13849-1: 2006

- ▶ Safety function: Shut down machine via E-STOP
- ▶ Safety-related parts of the control system (SRP/CS): Input device (E-STOP button), logic (PNOZ s5), actuator (contactors KM1 and KM2)
- ▶ Performance level: **PL e**
- ▶ PL information only applies under the following conditions\*:
  - Common cause failure (CCF): Requirements are considered to be met (must be tested on implementation)
  - Proof test interval: 20 years
  - Operating interval (electromechanical components): One operation per week for input device and actuator
  - Contactors KM1/KM2 - characteristic data:  $B10_d: 2,000,000$ ; dangerous failure rate: 65 %

\* Further requirements of EN 62061 and EN ISO 13849-1 have also to be met (e.g. requirements for systematic safety integrity and avoiding systematic faults, among others).

Минск +375447584780 viber zakaz@igt.by

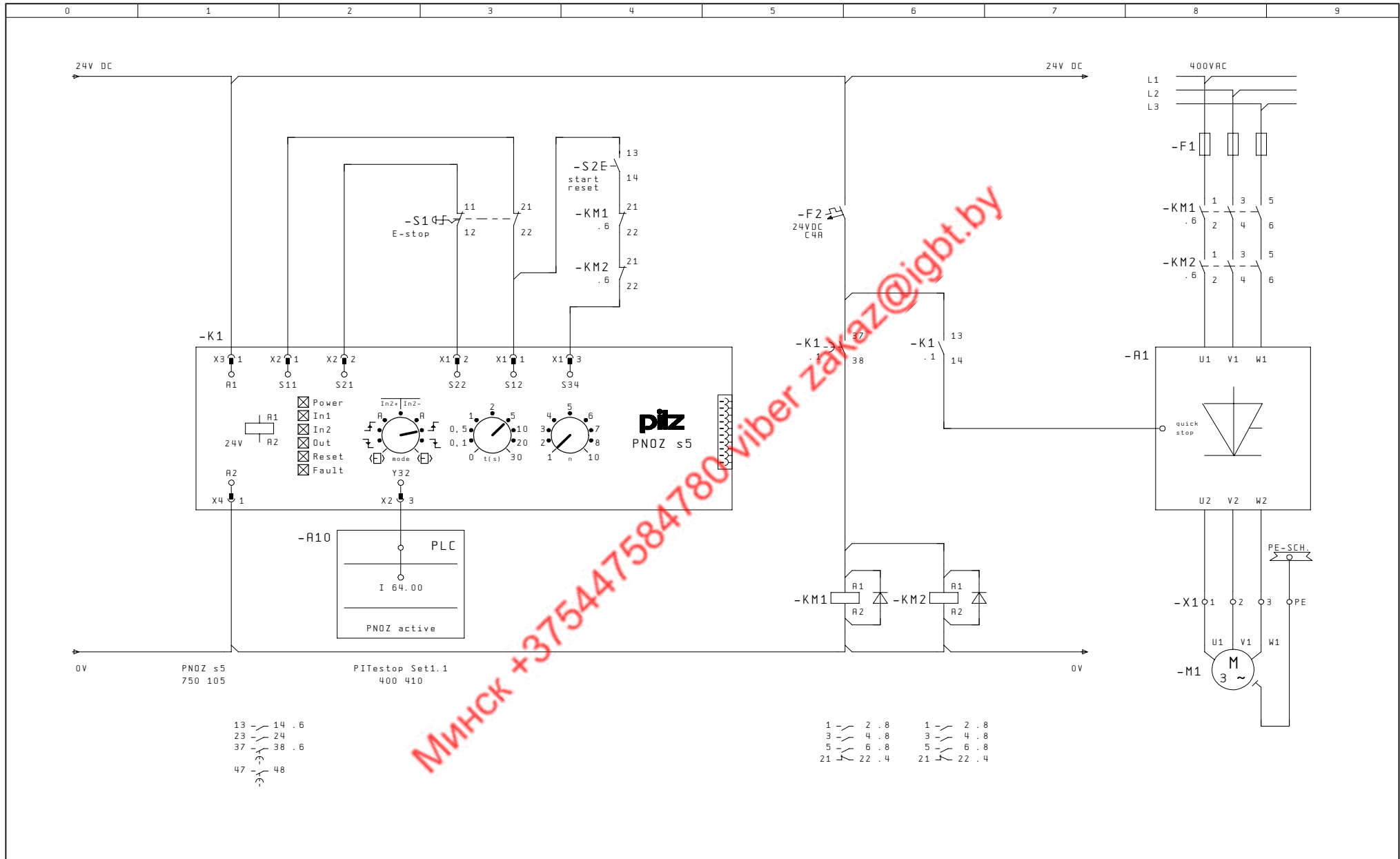

Revision	15.03.06	Date	07.12.05	Emergency stop application	Pilz GmbH & Co. KG Felix-Wankel-Str. 2 73760 Ostfildern	Safe stopping of a drive by emergency stop	Directory:
Name	WED	Name	WED				.. PNOZ\05PIL013
		Dep.	CS	Category 4 EN 954-1			PNOZs5
							Page: 1

МИНСК +375447584780 viber zakaz@igbt.by

## Category 4, EN 954-1

### PNOZ s5 - Safe standstill of two drives

#### Features

- ▶ Dual-channel operation with detection of shorts across contacts
- ▶ Monitored reset with rising edge
- ▶ Safe standstill of two drives after E-STOP
- ▶ Contact expansion through positive-guided contactors
- ▶ Feedback loop to monitor contact expansion
- ▶ Up to Category 4 of EN 954-1
- ▶ Stop category 1 in accordance with EN 60204-1

#### Description

Both drive controllers A2 and A3 have different braking times, so it must be possible to separate them from the mains independently in terms of time.

#### E-STOP function

When the E-STOP pushbutton S3 is operated, both the drives and the supply to the drives are shut down after a delay time. When the E-STOP pushbutton S3 is operated, the input circuit on the safety relay PNOZ s5 (K2) is interrupted, safety contacts 13-14 and 23-24 on K2 open immediately and trigger a “fast stop” at both the drive controllers A2 and A3.

The delay-on de-energisation safety contact 37-38 on K2 switches off contactors KM3 and KM4 after a delay. In this way, the drive controller A2 is isolated from the energy supply (mains) after a delay. The delay-on de-energisation time is set on the safety relay PNOZ s5 (K2). As a result the input circuit on safety relay PNOZ s9 (K3) is interrupted, the safety contacts on K3 switch off after a delay. The delay-on de-energisation contact 17-18 on K3 switches off contactors KM5 and KM6 after a delay. In this way, the drive controller A3 is isolated from the energy supply (mains) after a delay. The delay-on de-energisation time is set on the safety relay PNOZ s9 (K3).

#### Settings on the unit

- ▶ The connector between the safety relays PNOZ s5 (K2) and PNOZ s9 (K3) must be connected.
- ▶ The operating mode selector switch (mode) on the safety relay PNOZ s5 (K2) must be set to “Monitored reset, rising edge” with detection of shorts across contacts (In2-).
- ▶ The delay time on the safety relays PNOZ s5 (K2) and PNOZ s9 (K3) is set using the time selector switch t[s] and the factor selector switch n.
- ▶ The operating mode selector switch (mode) on the safety relay PNOZ s9 (K3) must be set to “Delay-on de-energisation”.

#### Start/reset

The safety relay PNOZ s5 (K2) can be started by pressing reset button S4 if:

- ▶ E-STOP pushbutton S3 has not been operated and
- ▶ Contactors KM3, KM4, KM5 and KM6 have dropped out.
- ▶ The feedback loop on safety relay PNOZ s9 (K3) is closed.

#### Feedback loop

The positive-guided N/C contacts on contactors KM3, KM4, KM5 and KM6 are monitored in feedback loop S12-S34 of safety relay PNOZ s5 (K2). The feedback loop on the safety relay PNOZ s5 (K2) is connected to the feedback loop on the safety relay PNOZ s9 (K3).

#### Safety assessment

- ▶ The safety relays PNOZ s5 (K2), PNOZ s9 (K3) and contactors KM3, KM4, KM5 and KM6 must be installed in a single mounting area (control cabinet) in order to exclude a short across the output.
- ▶ Earth faults and shorts between contacts in the input circuit are detected.
- ▶ A fault on the device does not lead to the loss of the safety function.

#### Pilz products

Number	Designation	Order number
1	PNOZ s5	750 105
1	PNOZ s9	750 109
1	PITestop Set1.1	400 410

- ▶ The safety relays PNOZ s5 (K2) and PNOZ s9 (K3) can be started when the input circuit at K2 is closed first, followed by reset button S4. This avoids an unwanted reset before the input circuit is closed or as a result of the reset button being overridden.
- ▶ The delay time set for the safety relay PNOZ s5 (K2) must be longer than the maximum braking time on the drive regulator A2. The delay time set for the safety relay PNOZ s9 (K3) must be longer than the maximum braking time on the drive regulator A3.
- ▶ The time delay must not be able to cause an additional hazard.
- ▶ If the position of the operating mode selector switch (mode) or the rotary switch for the time setting is changed during operation, an error message will be triggered; the safety contacts on K2 and K3 open. This fault condition can only be rectified by switching the supply voltage on the safety relay PNOZ s5 (K2) off and then on again.

## Category 4, EN 954-1

### PNOZ s5 - Safe standstill of two drives

#### Safety-related characteristics in accordance with EN 62061: 2005

- ▶ Safety-related control function 1 (SRCF1): Delayed shutdown of motor M2 via E-STOP
- ▶ Subsystems: Input device (E-STOP button), logic (PNOZ s5), actuator (contactors KM3 and KM4)
- ▶ Safety integrity level: **SIL 3**
- ▶ Safety-related control function 2 (SRCF2): Delayed shutdown of motor M3 via E-STOP
- ▶ Subsystems: Input device (E-STOP button), logic (PNOZ s5 + s9), actuator (contactors KM5 and KM6)
- ▶ Safety integrity level: **SIL 3**
- ▶ SIL information only applies under the following conditions\*:
  - Common cause failure (CCF):  $\beta = 10 \%$
  - Proof test interval: 20 years
  - Operating interval (electromechanical components): One operation per week for input device and actuator
  - Contactors KM3/KM4/KM5/KM6 - characteristic data:  $B10_d: 2,000,000$ ; dangerous failure rate: 65 %

#### Safety-related characteristics in accordance with EN ISO 13849-1: 2006

- ▶ Safety function 1: Delayed shutdown of motor M2 via E-STOP
- ▶ Safety-related parts of the control system (SRP/CS1): Input device (E-STOP button), logic (PNOZ s5), actuator (contactors KM3 and KM4)
- ▶ Performance level: **PL e**
- ▶ Safety function 2: Delayed shutdown of motor M3 via E-STOP
- ▶ Safety-related parts of the control system (SRP/CS2): Input device (E-STOP button), logic (PNOZ s5 + s9), actuator (contactors KM5 and KM6)
- ▶ Performance level: **PL e**
- ▶ PL information only applies under the following conditions\*:
  - Common cause failure (CCF): Requirements are considered to be met (must be tested on implementation)
  - Proof test interval: 20 years
  - Operating interval (electromechanical components): One operation per week for input device and actuator
  - Contactors KM1/KM2 - characteristic data:  $B10_d: 2,000,000$ ; dangerous failure rate: 65 %

\* Further requirements of EN 62061 and EN ISO 13849-1 have also to be met (e.g. requirements for systematic safety integrity and avoiding systematic faults, among others).

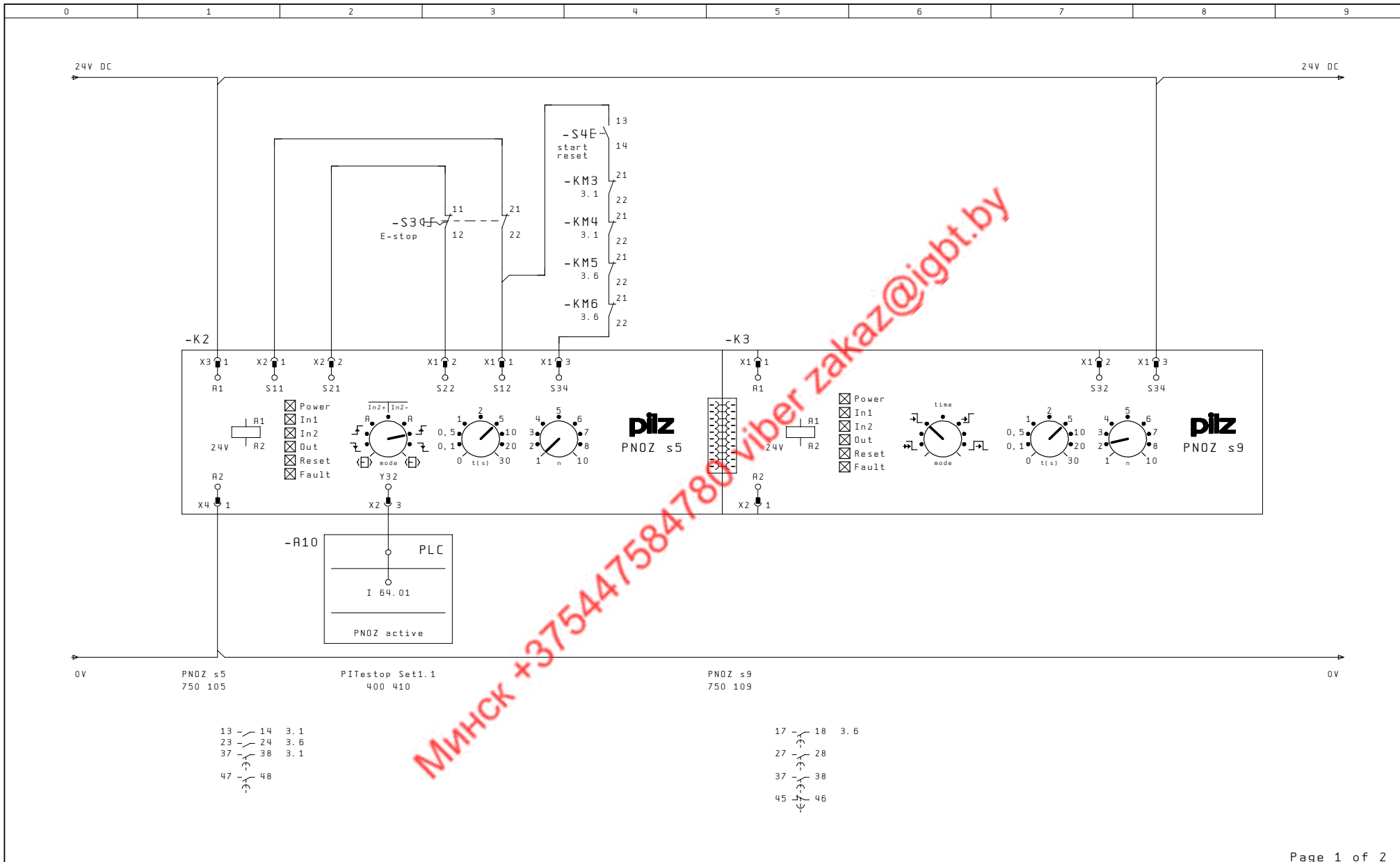

Revision	15.03.06	Date	07.12.05	Emergency stop application	Pilz GmbH & Co. KG Felix-Wankel-Str. 2 73760 Ostfildern	Safe stopping of two drives by emergency stop	Directory:
Name	WED	Name	WED				.. PNOZ\05PIL013
		Dep.	CS	Category 4 EN 954-1			PNOZ s5
							Page: 2

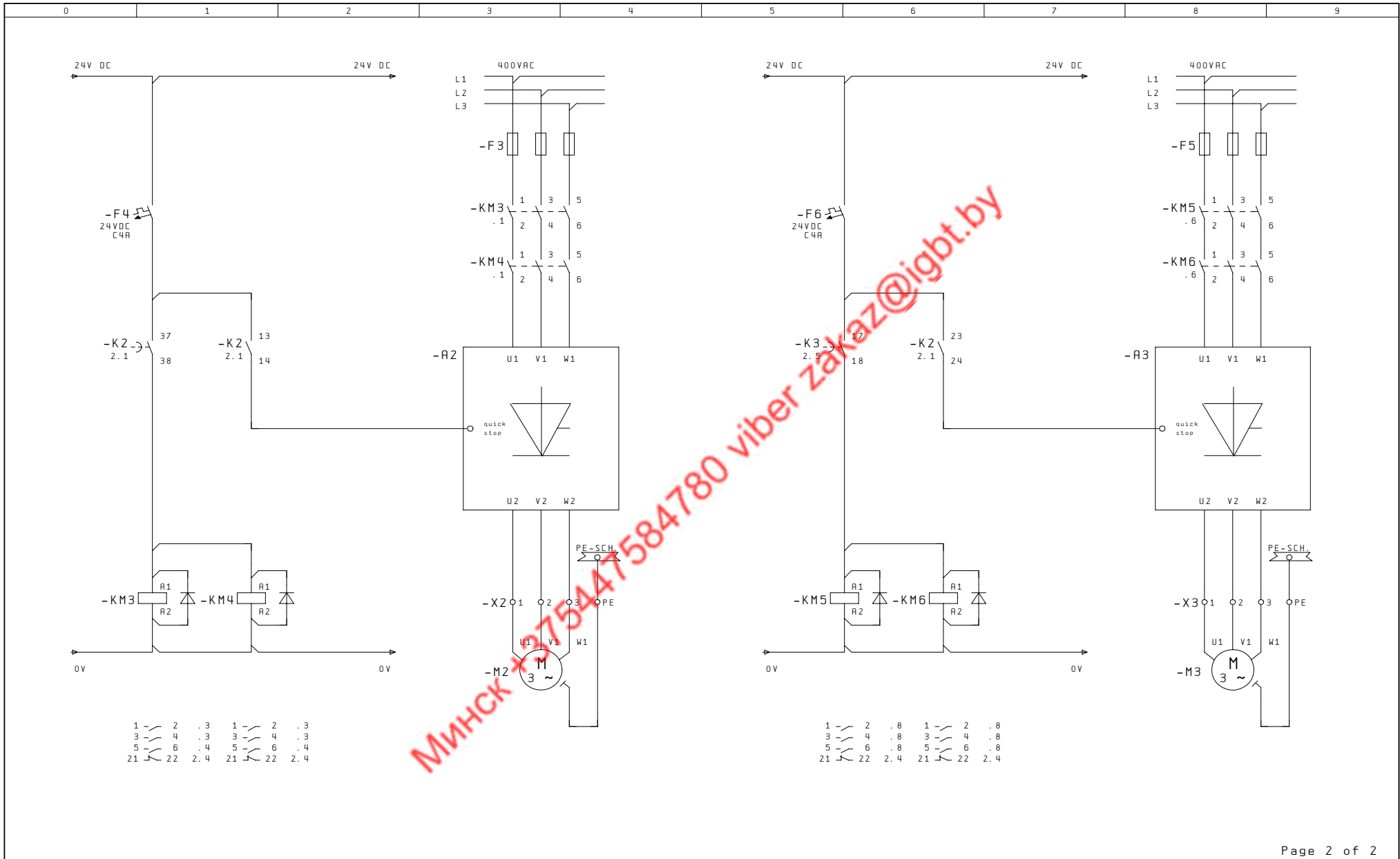

Мінск +375 44 7584780 viber zakaz@igbt.by

Revision	15.03.06	Date	07.12.05	Emergency stop application	 Pilz GmbH & Co. KG Felix-Wankel-Str. 2 73760 Ostfildern	Safe stopping of two drives by emergency stop	Directory:
Name	WED	Name	WED				.. PNOZ\05PIL013
		Dep.	CS	Category 4 EN 954-1			PNOZs5
							Page: 3

## Category 4, EN 954-1

### PNOZ s5 - Combined with two PNOZ s7

#### Features

- ▶ Dual-channel operation with detection of shorts across contacts
- ▶ Monitored reset with rising edge
- ▶ Contact expansion through two PNOZ s7
- ▶ Feedback loop to monitor contact expansion
- ▶ No delayed safety contacts (time selector switch t[s] set to "0")
- ▶ Up to Category 4 of EN 954-1

#### Description

##### E-STOP function

When the E-STOP pushbutton S5 is operated, the input circuit on the safety relay PNOZ s5 (K4) is interrupted, the safety contacts on K4 open. As a result the input circuit on the contact expander module PNOZ s7 (K5) is interrupted, the safety contacts on K5 open. As a result the supply voltage on the contact expander module PNOZ s7 (K6) is interrupted, the safety contacts on K6 open.

As the time selector switch t[s] is set to 0, all the safety contacts on the safety relay PNOZ s5 (K4) switch off immediately.

#### Settings on the unit

- ▶ The connector between the safety relays PNOZ s5 (K4) and PNOZ s7 (K5) must be connected.
- ▶ The terminator on the PNOZ s7 (K6) must be connected.
- ▶ The operating mode selector switch (mode) on the safety relay PNOZ s5 (K4) must be set to "Monitored reset, rising edge with detection of shorts across contacts (In2-)".
- ▶ On the safety relay PNOZ s5 (K4), the time selector switch t[s] must be set to "0" and the factor selector switch n to "1".

#### Start/reset

The safety relay PNOZ s5 (K4) can be started by pressing reset button S6 if:

- ▶ E-STOP pushbutton S5 has not been operated and
- ▶ Safety relay PNOZ s7 (K6) has de-energised and
- ▶ The feedback loop on contact expander module K5 is closed.

#### Feedback loop

The positive-guided N/C contact on the safety relay PNOZ s7 (K6) is monitored in feedback loop S12-S34 of safety relay PNOZ s5 (K4).

#### Safety assessment

- ▶ Earth faults and shorts between contacts in the input circuit are detected.
- ▶ A fault on the device does not lead to the loss of the safety function.
- ▶ The safety relays PNOZ s5 (K4), PNOZ s7 (K5) and PNOZ s7 (K6) can be started when the input circuit at K4 is closed first, followed by reset button S6. This avoids an unwanted reset before the input circuit is closed or as a result of the reset button being overridden.

- ▶ If the position of the operating mode selector switch (mode) or the rotary switch for the time setting is changed during operation, an error message will be triggered; the safety contacts on K4 open. This fault condition can only be rectified by switching the supply voltage on the safety relay PNOZ s5 (K4) off and then on again.

#### Pilz products

Number	Designation	Order number
1	PNOZ s5	750 105
2	PNOZ s7	750 107
1	PITestop Set1.1	400 410

## Category 4, EN 954-1

### PNOZ s5 - Combined with two PNOZ s7

#### Safety-related characteristics in accordance with EN 62061: 2005

- ▶ Safety-related control function (SRCF): Shut down machine via E-STOP
- ▶ Subsystems: Input device (E-STOP button), logic (PNOZ s5 + PNOZ s7), actuator (PNOZ s7)
- ▶ Safety integrity level: **SIL 3**
- ▶ SIL information only applies under the following conditions\*:
  - Common cause failure (CCF):  $\beta = 10 \%$
  - Proof test interval: 20 years
  - Operating interval (electromechanical components): One operation per week for input device

#### Safety-related characteristics in accordance with EN ISO 13849-1: 2006

- ▶ Safety function: Shut down machine via E-STOP
- ▶ Safety-related parts of the control system (SRP/CS): Input device (E-STOP button), logic (PNOZ s5 + PNOZ s7), actuator (PNOZ s7)
- ▶ Performance level: **PL e**
- ▶ PL information only applies under the following conditions\*:
  - Common cause failure (CCF): Requirements are considered to be met (must be tested on implementation)
  - Proof test interval: 20 years
  - Operating interval (electromechanical components): One operation per week for input device

\* Further requirements of EN 62061 and EN ISO 13849-1 have also to be met (e.g. requirements for systematic safety integrity and avoiding systematic faults, among others).

Минск +375447584780 viber zakaz@igbt.by

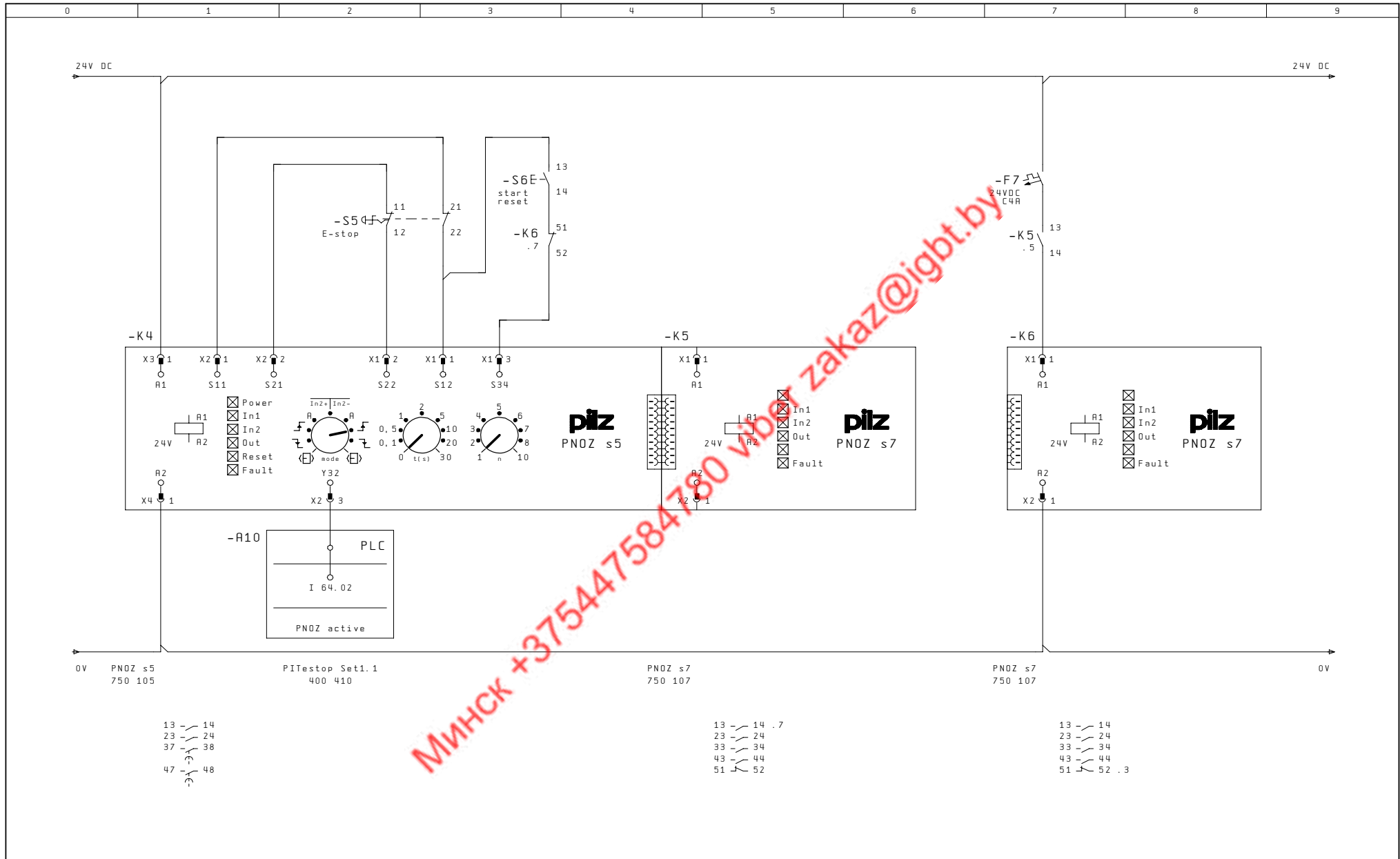

Мінск +375447584780 відб. заказ@igbt.by

Revision	15.03.06	Date	07.12.05	Emergency stop application	<b>pilz</b> Pilz GmbH & Co. KG Felix-Wankel-Str. 2 73760 Ostfildern	Emergency stop, extension contact by two PNOZ s7 and monitored start	Directory:
Name	WED	Name	WED				.. PNOZ\05PIL013
		Dep.	CS	Category 4 EN 954-1			PNOZ s5
							Page: 4

Минск +375447584780 viber zakaz@igbt.by

## Category 2, EN 954-1

### PNOZ s7 - Combined with PNOZ s2

#### Features

- ▶ Single-channel operation
- ▶ Monitored reset with rising edge
- ▶ Contact expansion through PNOZ s7 (contact expander module) and positive-guided contactor
- ▶ Feedback loop to monitor contact expansion
- ▶ Up to Category 2 of EN 954-1

#### Description

##### E-STOP function

When the E-STOP pushbutton S1 is operated, the supply voltage on the safety relay PNOZ s2 (K1) is interrupted, the safety contacts on K1 open. As a result the input circuit on the contact expander module PNOZ s7 (K2) is interrupted, the safety contacts on K2 open. Contactor K3 de-energises.

##### Settings on the unit

- ▶ The connector between the safety relays PNOZ s2 (K1) and PNOZ s7 (K2) must be connected.
- ▶ The operating mode selector switch (mode) on the safety relay PNOZ s2 (K1) must be set to "Monitored reset, rising edge".

##### Start/reset

The safety relay PNOZ s2 (K1) can be started by pressing reset button S2 if:

- ▶ E-STOP pushbutton S1 has not been operated and
- ▶ Contactor K3 has de-energised and
- ▶ The feedback loop on the contact expander module PNOZ s7 (K2) is closed.

##### Feedback loop

The positive-guided N/C contact on contactor K3 is monitored in feedback loop A1-S34 of safety relay PNOZ s2 (K1). The feedback loop on the safety relay PNOZ s2 (K1) is connected to the feedback loop on the contact expander module PNOZ s7 (K2).

##### Safety assessment

- ▶ Earth fault in the input circuit is detected.
- ▶ A fault on the device does not lead to the loss of the safety function.
- ▶ The safety relays PNOZ s2 (K1) and PNOZ s7 (K2) can be started when the input circuit (supply voltage) at K1 is closed first, followed by the reset button S2. This avoids an unwanted reset before the input circuit is closed or as a result of the reset button being overridden.

- ▶ The safety relays PNOZ s2 (K1) and PNOZ s7 (K2) are tested in each on/off cycle. The E-STOP pushbutton S1 must be operated at appropriate intervals to perform a function test. This must be recorded in the machine's operating manual (organisational measure). An E-STOP is not a primary safety measure, just a precautionary measure for emergencies (EN ISO 12100-2). A start-up test is therefore not required. As the safety relays PNOZ s2 and PNOZ s7 cannot be tested automatically, a second shutdown route is required (e.g. via a main switch or a master contactor).

- ▶ If the position of the operating mode selector switch (mode) is changed during operation, an error message will be triggered; the safety contacts on K1 open. This fault condition can only be rectified by switching the supply voltage on the safety relay PNOZ s2 (K1) off and then on again.

#### Pilz products

Number	Designation	Order number
1	PNOZ s2	750 102
1	PNOZ s7	750 107
1	PIT es1.11	400 100
1	PIT esb1.1	400 305

## Category 2, EN 954-1

### PNOZ s7 - Combined with PNOZ s2

#### Safety-related characteristics in accordance with EN ISO 13849-1: 2006

▶ Safety function:	Shut down machine via E-STOP
▶ Safety-related parts of the control system (SRP/CS):	Input device (E-STOP button), logic (PNOZ s2 + PNOZ s7), actuator (contactor K3)
▶ Performance level:	<b>PL c</b>
▶ PL information only applies under the following conditions*:	
- Common cause failure (CCF):	Requirements are considered to be met (must be tested on implementation)
- Proof test interval:	20 years
- Operating interval (electromechanical components):	One operation per week for input device and actuator
- Contactor K3 - characteristic data:	B10 <sub>d</sub> : 2,000,000; dangerous failure rate: 65 %

\* Further requirements of EN ISO 13849-1 have also to be met (e.g. requirements for avoiding systematic faults, among others).

Минск +375447584780 viber zakaz@igt.by

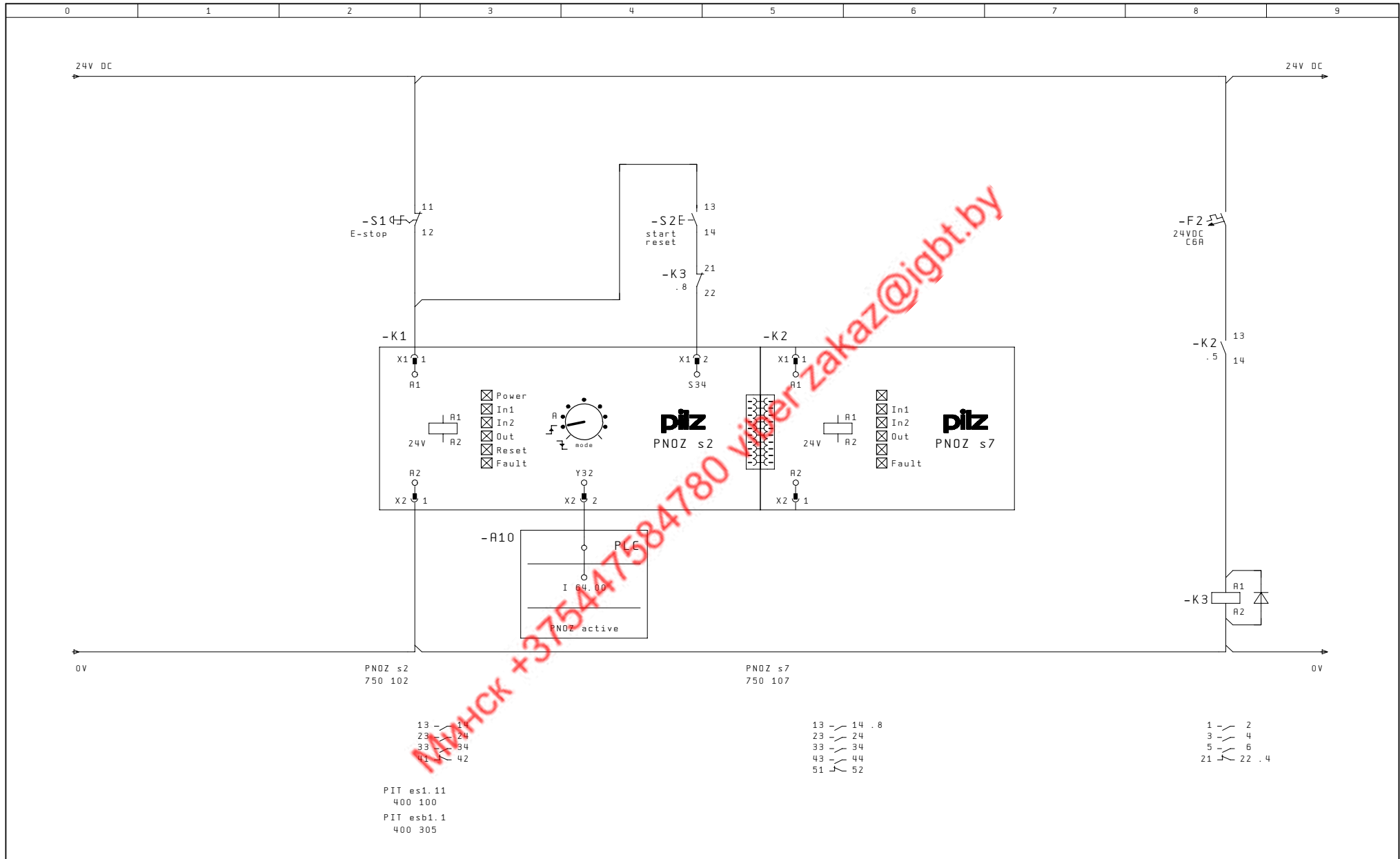

Revision	20.03.06	Date	07.12.05	Emergency stop application	<b>pilz</b> Pilz GmbH & Co. KG Felix-Wankel-Str. 2 73760 Ostfildern	Emergency stop, extension contact by PNOZ s7 and contactor, monitored start	Directory:
Name	WED	Name	WED				.. PNOZ\05PIL013
		Dep.	CS	Category 2 EN 954-1			PNOZs7
							Page: 1

МИНСК +375447584780 viber zakaz@igbt.by

## Category 4, EN 954-1

### PNOZ s7 - Combined with PNOZ s4

#### Features

- ▶ Dual-channel operation with detection of shorts across contacts
- ▶ Monitored reset with rising edge
- ▶ Contact expansion through PNOZ s7 (contact expander module) and positive-guided contactors
- ▶ Feedback loop to monitor contact expansion
- ▶ Up to Category 4 of EN 954-1

#### Description

##### E-STOP function

When the E-STOP pushbutton S3 is operated, the input circuit on the safety relay PNOZ s4 (K4) is interrupted, the safety contacts on K4 open. As a result the input circuit on the contact expander module PNOZ s7 (K5) is interrupted, the safety contacts on K5 open. Contactors KM1 and KM2 de-energise.

##### Settings on the unit

- ▶ The connector between the safety relays PNOZ s4 (K4) and PNOZ s7 (K5) must be connected.
- ▶ The operating mode selector switch (mode) on the safety relay PNOZ s4 must be set to "Monitored reset, rising edge with detection of shorts across contacts (In2-)".

##### Start/reset

The safety relay PNOZ s4 (K4) can be started by pressing reset button S4 if:

- ▶ E-STOP pushbutton S3 has not been operated and
- ▶ The safety contacts on the contact expander module PNOZ s7 (K5) are open
- ▶ Contactors KM1 and KM2 have de-energised and
- ▶ The feedback loop on the contact expander module PNOZ s7 (K5) is closed.

##### Feedback loop

The positive-guided N/C contacts on contactors KM1 and KM2 are monitored in feedback loop S12-S34 of safety relay PNOZ s4 (K4). The feedback loop on the safety relay PNOZ s4 (K4) is connected to the feedback loop on the contact expander module PNOZ s7 (K5).

##### Safety assessment

- ▶ The safety relays K4 and K5 and contactors KM1 and KM2 must be installed in a single mounting area (control cabinet) in order to exclude a short across the output.
- ▶ Earth faults and shorts between contacts in the input circuit are detected.
- ▶ A fault on the device does not lead to the loss of the safety function.

- ▶ The safety relays PNOZ s4 (K4) and PNOZ s7 (K5) can be started when the input circuit at K4 is closed first, followed by reset button S4. This avoids an unwanted reset before the input circuit is closed or as a result of the reset button being overridden.
- ▶ If the position of the operating mode selector switch (mode) is changed during operation, an error message will be triggered; the safety contacts on K4 open. This fault condition can only be rectified by switching the supply voltage on the safety relay PNOZ s4 (K4) off and then on again.

#### Pilz products

Number	Designation	Order number
1	PNOZ s4	750 104
1	PNOZ s7	750 107
1	PI Testop Set1.1	400 410

## Category 4, EN 954-1

### PNOZ s7 - Combined with PNOZ s4

#### Safety-related characteristics in accordance with EN 62061: 2005

- ▶ Safety-related control function (SRCF): Shut down machine via E-STOP
- ▶ Subsystems: Input device (E-STOP button), logic (PNOZ s4 + PNOZ s7), actuator (contactors KM1 and KM2)
- ▶ Safety integrity level: **SIL 3**
- ▶ SIL information only applies under the following conditions\*:
  - Common cause failure (CCF):  $\beta = 10 \%$
  - Proof test interval: 20 years
  - Operating interval (electromechanical components): One operation per week for input device and actuator
  - Contactors KM1/KM2 - characteristic data:  $B10_d: 2,000,000$ ; dangerous failure rate: 65 %

#### Safety-related characteristics in accordance with EN ISO 13849-1: 2006

- ▶ Safety function: Shut down machine via E-STOP
- ▶ Safety-related parts of the control system (SRP/CS): Input device (E-STOP button), logic (PNOZ s4 + PNOZ s7), actuator (contactors KM1 and KM2)
- ▶ Performance level: **PL e**
- ▶ PL information only applies under the following conditions\*:
  - Common cause failure (CCF): Requirements are considered to be met (must be tested on implementation)
  - Proof test interval: 20 years
  - Operating interval (electromechanical components): One operation per week for input device and actuator
  - Contactors KM1/KM2 - characteristic data:  $B10_d: 2,000,000$ ; dangerous failure rate: 65 %

\* Further requirements of EN 62061 and EN ISO 13849-1 have also to be met (e.g. requirements for systematic safety integrity and avoiding systematic faults, among others).

Минск +375 29 7584780 viber @kaz@igt.by

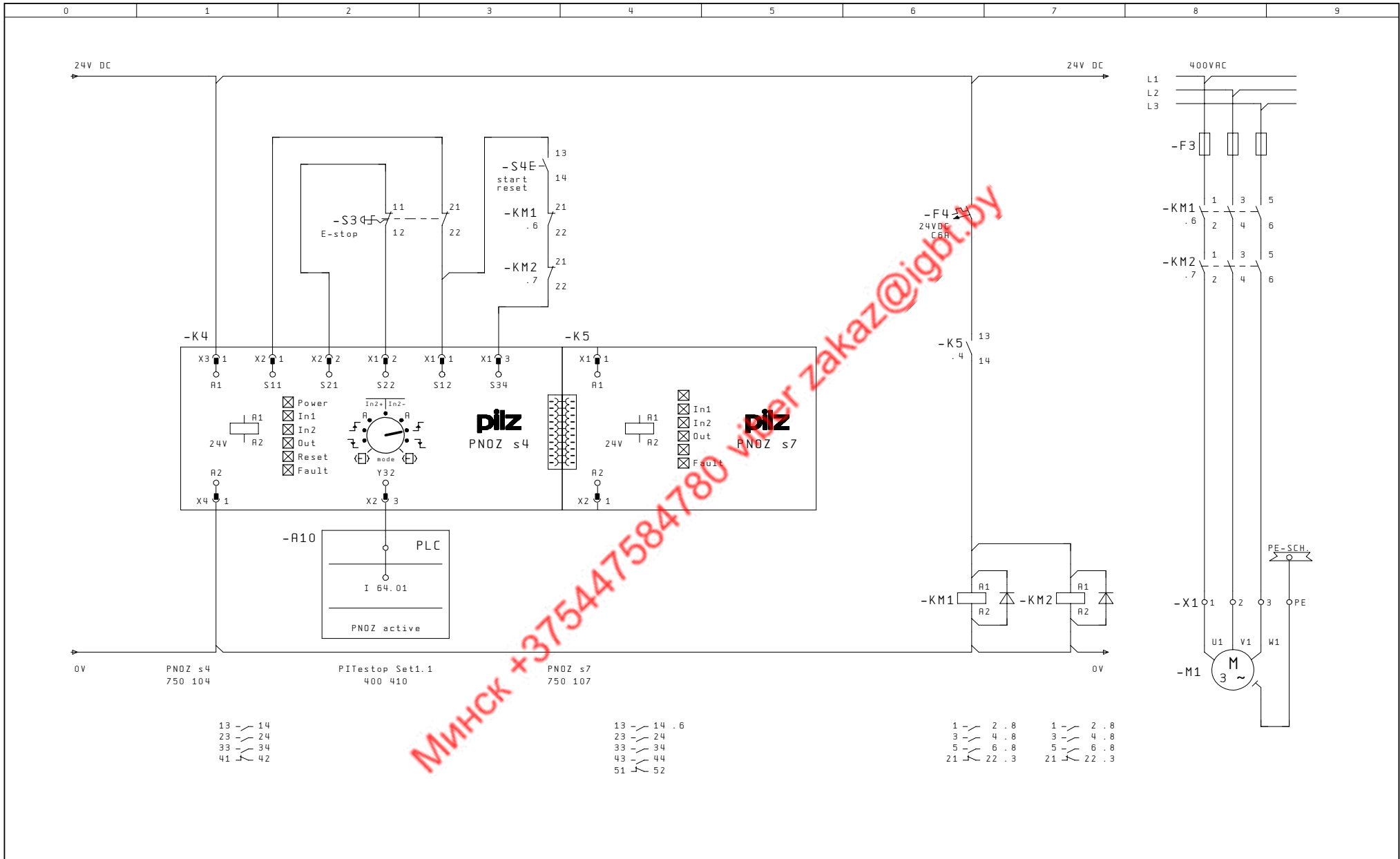

Revision	08.03.06	Date	07.12.05	Emergency stop application		Pilz GmbH & Co. KG Felix-Wankel-Str. 2 73760 Ostfildern	Emergency stop, extension contact by PNOZ s7 and contactor, monitored start	Directory:
Name	WED	Name	WED					.. PNOZ\05PIL013
		Dep.	CS	Category 4 EN 954-1				PNOZs7
								Page: 2

МИНСК +375447584780 viber zakaz@igbt.by

## Category 2, EN 954-1

### PNOZ s8 - Combined with PNOZ s1

#### Features

- ▶ Single-channel operation
- ▶ Monitored reset
- ▶ Contact expansion through PNOZ s8 (contact expander module) and positive-guided contactor
- ▶ Feedback loop to monitor contact expansion
- ▶ Up to Category 2 of EN 954-1

#### Description

##### E-STOP function

When the E-STOP pushbutton S1 is operated, the supply voltage on the safety relay PNOZ s1 (K1) is interrupted, the safety contacts on K1 open. As a result the input circuit on the contact expander module PNOZ s8 (K2) is interrupted, the safety contacts on K2 open. Contactor K3 de-energises.

##### Settings on the unit

- ▶ The connector between the safety relays PNOZ s1 (K1) and PNOZ s8 (K2) must be connected.

##### Start/reset

The safety relay PNOZ s1 (K1) can be started by pressing reset button S2 if:

- ▶ E-STOP pushbutton S1 has not been operated and

- ▶ Contactor K3 has de-energised and
- ▶ The feedback loop on the contact expander module PNOZ s8 (K2) is closed.

##### Feedback loop

The positive-guided N/C contact on contactor K3 is monitored in feedback loop A1-S34 of safety relay PNOZ s1 (K1). The feedback loop on the safety relay PNOZ s1 (K1) is connected to the feedback loop on the contact expander module PNOZ s8 (K2).

##### Safety assessment

- ▶ Earth fault in the input circuit is detected.
- ▶ A fault on the device does not lead to the loss of the safety function.
- ▶ The safety relays PNOZ s1 (K1) and PNOZ s8 (K2) can be started when the input circuit (supply voltage) at K1 is closed first, followed by the reset button S2. This avoids an unwanted reset before the input circuit is closed or as a result of the reset button being overridden.
- ▶ The safety relays PNOZ s1 (K1) and PNOZ s8 (K2) are tested in each on/off cycle. The E-STOP pushbutton S1 must be operated at appropriate intervals to perform a function test. This must be recorded in the machine's operating manual (organisational measure). An E-STOP is not a primary safety measure, just a precautionary measure for

emergencies

(EN ISO 12100-2). A start-up test is therefore not required.

As the safety relays PNOZ s1 and PNOZ s8 cannot be tested automatically, a second shutdown route is required (e.g. via a main switch or a master contactor).

#### Pilz products

Number	Designation	Order number
1	PNOZ s1	750 101
1	PNOZ s8	750 108
1	PIT es1.11	400 100
1	PIT esb1.1	400 305

## Category 2, EN 954-1

### PNOZ s8 - Combined with PNOZ s1

#### Safety-related characteristics in accordance with EN ISO 13849-1: 2006

- |  |  |
|--|--|
| ▶ Safety function:   | Shut down machine via E-STOP   |
| ▶ Safety-related parts of the control system (SRP/CS):         | Input device (E-STOP button), logic (PNOZ s1 + PNOZ s8), actuator (contactor K3) |
| ▶ Performance level:   | <b>PL c</b>  |
| ▶ PL information only applies under the following conditions*: |  |
| - Common cause failure (CCF):                                  | Requirements are considered to be met (must be tested on implementation)         |
| - Proof test interval:   | 20 years   |
| - Operating interval (electromechanical components):           | One operation per week for input device and actuator                             |
| - Contactor K3 - characteristic data:                          | B10 <sub>d</sub> : 2,000,000; dangerous failure rate: 65 %                       |

\* Further requirements of EN 62061 and EN ISO 13849-1 have also to be met (e.g. requirements for systematic safety integrity and avoiding systematic faults, among others).

Минск +375447584780 viber zakaz@igt.by

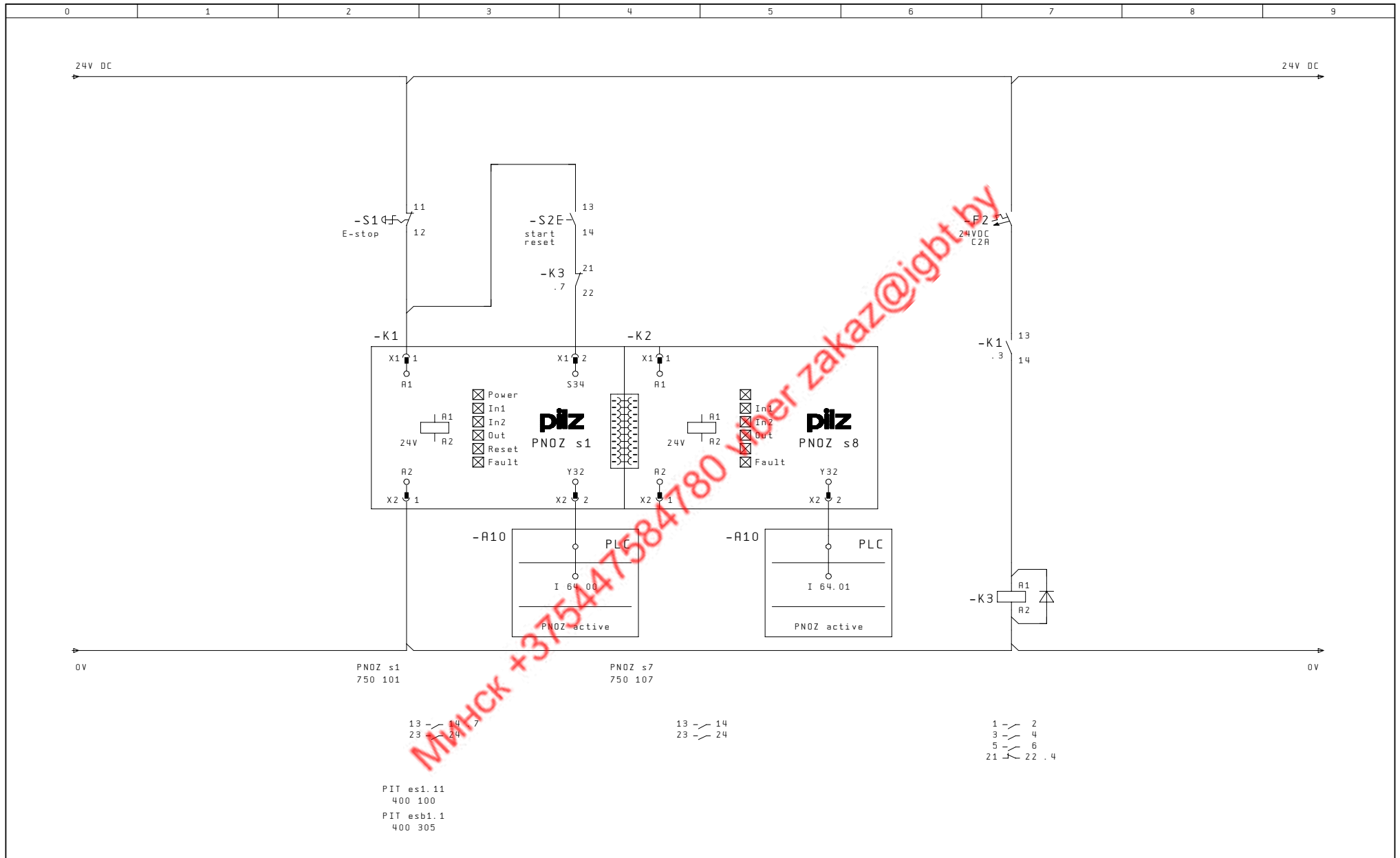

Revision	20.03.06	Date	07.12.05	Emergency stop application	<b>pilz</b> Pilz GmbH & Co. KG Felix-Wankel-Str. 2 73760 Ostfildern	Emergency stop, extension contact by contactor and manual start	Directory:
Name	WED	Name	WED				.. PNOZ\05PIL013
		Dep.	CS	Category 2 EN 954-1			PNOZ s8
							Page: 1

МИНСК +375447584780 viber zakaz@igbt.by

## Category 4, EN 954-1

### PNOZ s9 - Combined with PNOZ s4 - safe standstill of one drive

#### Features

- ▶ Dual-channel operation with detection of shorts across contacts
- ▶ Monitored reset with rising edge
- ▶ Safe standstill of one drive after E-STOP
- ▶ Contact expansion through positive-guided contactors
- ▶ Feedback loop to monitor contact expansion
- ▶ Up to Category 4 of EN 954-1
- ▶ Stop category 1 in accordance with EN 60204-1

#### Description

##### E-STOP function

When the E-STOP pushbutton S9 is operated, both the drive and the supply to the drive are shut down after a delay time. When the E-STOP pushbutton S9 is operated, the input circuit on the safety relay PNOZ s4 (K11) is interrupted, safety contact 14 on K11 opens immediately and triggers a “fast stop” at the drive controller A1.

As a result the input circuit on safety relay PNOZ s9 (K12) is interrupted and the delay-on de-energisation safety contacts on K12 switch off contactors KM1 and KM2 after a delay. In this way, the drive controller A1 is isolated from the energy supply (mains) after

a delay. The delay-on de-energisation time is set on the safety relay PNOZ s9 (K12).

##### Settings on the unit

- ▶ The connector between the safety relays PNOZ s4 (K11) and PNOZ s9 (K12) must be connected.
- ▶ The operating mode selector switch (mode) on the safety relay PNOZ s4 (K11) must be set to “Monitored reset, rising edge” with detection of shorts across contacts (In2-).
- ▶ The operating mode selector switch (mode) on the safety relay PNOZ s9 (K12) must be set to “Delay-on energisation”.
- ▶ The delay time on the safety relay PNOZ s9 (K12) is set using the time selector switch t[s] and the factor selector switch n.

##### Start/reset

The safety relay PNOZ s4 (K11) can be started by pressing reset button S10 if:

- ▶ E-STOP pushbutton S9 has not been operated and
- ▶ Contactors KM1 and KM2 have de-energised and
- ▶ The feedback loop on safety relay PNOZ s9 (K12) is closed.

##### Feedback loop

The positive-guided N/C contacts on contactors KM1 and KM2 are monitored in feedback loop S12-S34 of safety relay K11. The feedback loop on the safety relay PNOZ s4 (K11) is connected to the feedback loop on the contact expander module PNOZ s9 (K12).

##### Safety assessment

- ▶ The safety relays PNOZ s4 (K11) and PNOZ s9 (K12) and contactors KM1 and KM2 must be installed in a single mounting area (control cabinet) in order to exclude a short across the output.
- ▶ Earth faults and shorts between contacts in the input circuit are detected.
- ▶ A fault on the device does not lead to the loss of the safety function.

- ▶ The safety relays PNOZ s4 (K11) and PNOZ s9 (K12) can be started when the input circuit at K11 is closed first, followed by reset button S10. This avoids an unwanted reset before the input circuit is closed or as a result of the reset button being overridden.
- ▶ The delay time set for the safety relay PNOZ s9 (K12) must be longer than the maximum braking time on the drive regulator A1.
- ▶ The time delay must not be able to cause an additional hazard.
- ▶ If the position of the operating mode selector switch (mode) or the rotary switch for the time setting is changed during operation, an error message will be triggered; the safety contacts on K11 / K12 open. This fault condition can only be rectified by switching the supply voltage on the safety relay PNOZ s4 (K11) / PNOZ s9 (K12) off and then on again.

#### Pilz products

Number	Designation	Order number
1	PNOZ s4	750 104
1	PNOZ s9	750 109
1	PITestop Set1.1	400 410

## Category 4, EN 954-1

### PNOZ s9 - Combined with PNOZ s4 - safe standstill of one drive

#### Safety-related characteristics in accordance with EN 62061: 2005

- ▶ Safety-related control function (SRCF): Shut down machine via E-STOP
- ▶ Subsystems: Input device (E-STOP button), logic (PNOZ s4 and PNOZ s9), actuator (contactors KM1 and KM2)
- ▶ Safety integrity level: **SIL 3**
- ▶ SIL information only applies under the following conditions\*:
  - Common cause failure (CCF):  $\beta = 10 \%$
  - Proof test interval: 20 years
  - Operating interval (electromechanical components): One operation per week for input device and actuator
  - Contactors KM1/KM2 - characteristic data:  $B10_d: 2,000,000$ ; dangerous failure rate: 65 %

#### Safety-related characteristics in accordance with EN ISO 13849-1: 2006

- ▶ Safety function: Shut down machine via E-STOP
- ▶ Safety-related parts of the control system (SRP/CS): Input device (E-STOP button), logic (PNOZ s4 and PNOZ s9), actuator (contactors KM1 and KM2)
- ▶ Performance level: **PL e**
- ▶ PL information only applies under the following conditions\*:
  - Common cause failure (CCF): Requirements are considered to be met (must be tested on implementation)
  - Proof test interval: 20 years
  - Operating interval (electromechanical components): One operation per week for input device and actuator
  - Contactors KM1/KM2 - characteristic data:  $B10_d: 2,000,000$ ; dangerous failure rate: 65 %

\* Further requirements of EN 62061 and EN ISO 13849-1 have also to be met (e.g. requirements for systematic safety integrity and avoiding systematic faults, among others).

Минск +375 29 7584780 viber zakaz@igbt.by



МИНСК +375447584780 viber zakaz@igbt.by

## Category 4, EN 954-1

### PNOZ s10 - Combined with PNOZ s4

#### Features

- ▶ Dual-channel operation with detection of shorts across contacts
- ▶ Monitored reset with rising edge
- ▶ Contact expansion through PNOZ s10 (contact expander module)
- ▶ Feedback loop to monitor contact expansion
- ▶ Up to Category 4 of EN 954-1

#### Description

##### E-STOP function

When the E-STOP pushbutton S1 is operated, the input circuit on the safety relay PNOZ s4 (K1) is interrupted, the safety contacts on K1 open. As a result the input circuit on the contact expander module PNOZ s10 (K2) is interrupted, the safety contacts on K2 open.

##### Settings on the unit

- ▶ The connector between the safety relays PNOZ s4 (K1) and PNOZ s10 (K2) must be connected.
- ▶ The operating mode selector switch (mode) on the safety relay PNOZ s4 must be set to “Monitored reset, rising edge” with detection of shorts across contacts (In2-).

##### Start/reset

The safety relay PNOZ s4 (K1) can be started by pressing reset button S2 if:

- ▶ E-STOP pushbutton S1 has not been operated and
- ▶ The feedback loop on the contact expander module PNOZ s10 (K2) is closed.

##### Feedback loop

The feedback loop on the safety relay PNOZ s4 (K1) is connected to the feedback loop on the contact expander module PNOZ s10 (K2).

##### Safety assessment

- ▶ Earth faults and shorts between contacts in the input circuit are detected.
- ▶ A fault on the device does not lead to the loss of the safety function.
- ▶ The safety relays PNOZ s4 (K1) and PNOZ s10 (K2) can be started when the input circuit at K1 is closed first, followed by the reset button S2. This avoids an unwanted reset before the input circuit is closed or as a result of the reset button being overridden.

- ▶ If the position of the operating mode selector switch (mode) is changed during operation, an error message will be triggered; the safety contacts on K1 open. This fault condition can only be rectified by switching the supply voltage on the safety relay PNOZ s4 (K1) off and then on again.

##### Pilz products

Number	Designation	Order number
1	PNOZ s4	750 104
1	PNOZ s10	750 110
1	PITestop Set1.1	400 410

MW 0313 4758780 fiber zakat @ 0313

## Category 4, EN 954-1

### PNOZ s10 - Combined with PNOZ s4

#### Safety-related characteristics in accordance with EN 62061: 2005

- ▶ Safety-related control function (SRCF): Shut down machine via E-STOP
- ▶ Subsystems: Input device (E-STOP button), logic (PNOZ s4), actuator (PNOZ s10)
- ▶ Safety integrity level: **SIL 3**
- ▶ SIL information only applies under the following conditions\*:
  - Common cause failure (CCF):  $\beta = 10 \%$
  - Proof test interval: 20 years
  - Operating interval (electromechanical components): One operation per week for input device

#### Safety-related characteristics in accordance with EN ISO 13849-1: 2006

- ▶ Safety function: Shut down machine via E-STOP
- ▶ Safety-related parts of the control system (SRP/CS): Input device (E-STOP button), logic (PNOZ s4), actuator (PNOZ s10)
- ▶ Performance level: **PL e**
- ▶ PL information only applies under the following conditions\*:
  - Common cause failure (CCF): Requirements are considered to be met (must be tested on implementation)
  - Proof test interval: 20 years
  - Operating interval (electromechanical components): One operation per week for input device

\* Further requirements of EN 62061 and EN ISO 13849-1 have also to be met (e.g. requirements for systematic safety integrity and avoiding systematic faults, among others).

Минск +375447584780 viber zakaz@igbt.by



Contents		Page	
<b>Safety gate applications</b>			
PNOZ s3	- Safety switch PSEN cs2.1p	Category 4*	1.2-2
PNOZ s4	- Connecting four PSEN 1.1p in series	Category 3*	1.2-6
PNOZ s4	- PSEN me2/2AS	Category 4*	1.2-10
PNOZ s4	- PSEN me1S/1AS with guard locking and standstill monitoring	Category 4*	1.2-14
PNOZ s9	- PSEN me1S/1AS with guard locking and PSEN me2/2AS	Category 4*	1.2-18

\* in accordance with EN 954-1

Минск +375447584780 viber zakaz@pilot.by

## Category 4, EN 954-1

### PNOZ s3 – Safety switch PSEN cs2.1p

#### Features

- ▶ Dual-channel operation with detection of shorts across contacts via safety switch
- ▶ Monitored reset with rising edge
- ▶ Contact expansion through positive-guided contactors
- ▶ Feedback loop to monitor contact expansion
- ▶ Up to Category 4 of EN 954-1

#### Description

##### Safety gate function

The opening and closing of a safety gate is signalled to the safety relay PNOZ s3 (K2) via the semiconductor outputs on the safety switch PSEN cs2.1p (S3). The semiconductor outputs on safety switch S3 are opened as soon as the safety gate is opened. As a result the the input circuit on the safety relay PNOZ s3 (K2) is interrupted and the safety contacts on the PNOZ s3 (K2) open. Contactors K3 and K4 de-energise.

#### Settings on the unit

- ▶ The terminator on the PNOZ s3 must be connected.
- ▶ The operating mode selector switch (mode) on the safety relay PNOZ s3 must be set to “Monitored reset, rising edge” without detection of shorts across contacts (In2+).
- ▶ Increased protection against manipulation is required for hazardous machinery such as presses. In this case we recommend using two safety switches per safety gate.

#### Start/reset

The safety relay PNOZ s3 (K2) can be started by pressing reset button S4 if:

- ▶ The safety gate is closed and
- ▶ The semiconductor outputs on the safety switch S3 are closed and
- ▶ Contactors K3 and K4 have de-energised.

#### Feedback loop

The positive-guided N/C contacts on contactors K3 and K4 are monitored in the feedback loop S12-S34 of the safety relay K2.

#### Safety assessment

- ▶ Earth faults and shorts between contacts in the input circuit are detected through the safety switch S3.
- ▶ A fault on the device does not lead to the loss of the safety function.
- ▶ The safety relay PNOZ s3 (K2) can be started when the input circuit at K2 is closed first, followed by reset button S4. This avoids an unwanted reset before the input circuit is closed or as a result of the reset button being overridden.

- ▶ If the position of the operating mode selector switch (mode) is changed during operation, an error message will be triggered; the safety contacts on K2 open. This fault condition can only be rectified by switching the supply voltage on the safety relay K2 off and then on again.

#### Pilz products

Number	Designation	Order number
1	PNOZ s3	750 103
1	PSEN cs2.1p	540 100

## Category 4, EN 954-1

### PNOZ s3 – Safety switch PSEN cs2.1p

#### Safety-related characteristics in accordance with EN 62061: 2005

- ▶ Safety-related control function (SRCF): Shut down machine when a safety gate is opened
- ▶ Subsystems: Input device (E-STOP button), logic (PNOZ s3), actuator (contactors K3 and K4)
- ▶ Safety integrity level: **SIL 3**
- ▶ SIL information only applies under the following conditions\*:
  - Common cause failure (CCF):  $\beta = 10 \%$
  - Proof test interval: 20 years
  - Operating interval (electromechanical components): Two operations per hour for input device and actuator
  - Contactor K3/K4 - characteristic data:  $B10_d: 2,000,000$ ; dangerous failure rate: 65 %

#### Safety-related characteristics in accordance with EN ISO 13849-1: 2006

- ▶ Safety function: Shut down machine via E-STOP
- ▶ Safety-related parts of the control system (SRP/CS): Input device (E-STOP button), logic (PNOZ s3), actuator (contactors K3 and K4)
- ▶ Performance level: **PL e**
- ▶ PL information only applies under the following conditions\*:
  - Common cause failure (CCF): Requirements are considered to be met (must be tested on implementation)
  - Proof test interval: 20 years
  - Operating interval (electromechanical components): Two operations per hour for input device and actuator
  - Contactor K3/K4 - characteristic data:  $B10_d: 2,000,000$ ; dangerous failure rate: 65 %

\* Further requirements of EN 62061 and EN ISO 13849-1 have also to be met (e.g. requirements for systematic safety integrity and avoiding systematic faults, among others).

Мінск +375447584780 viber zakaz@igt.by

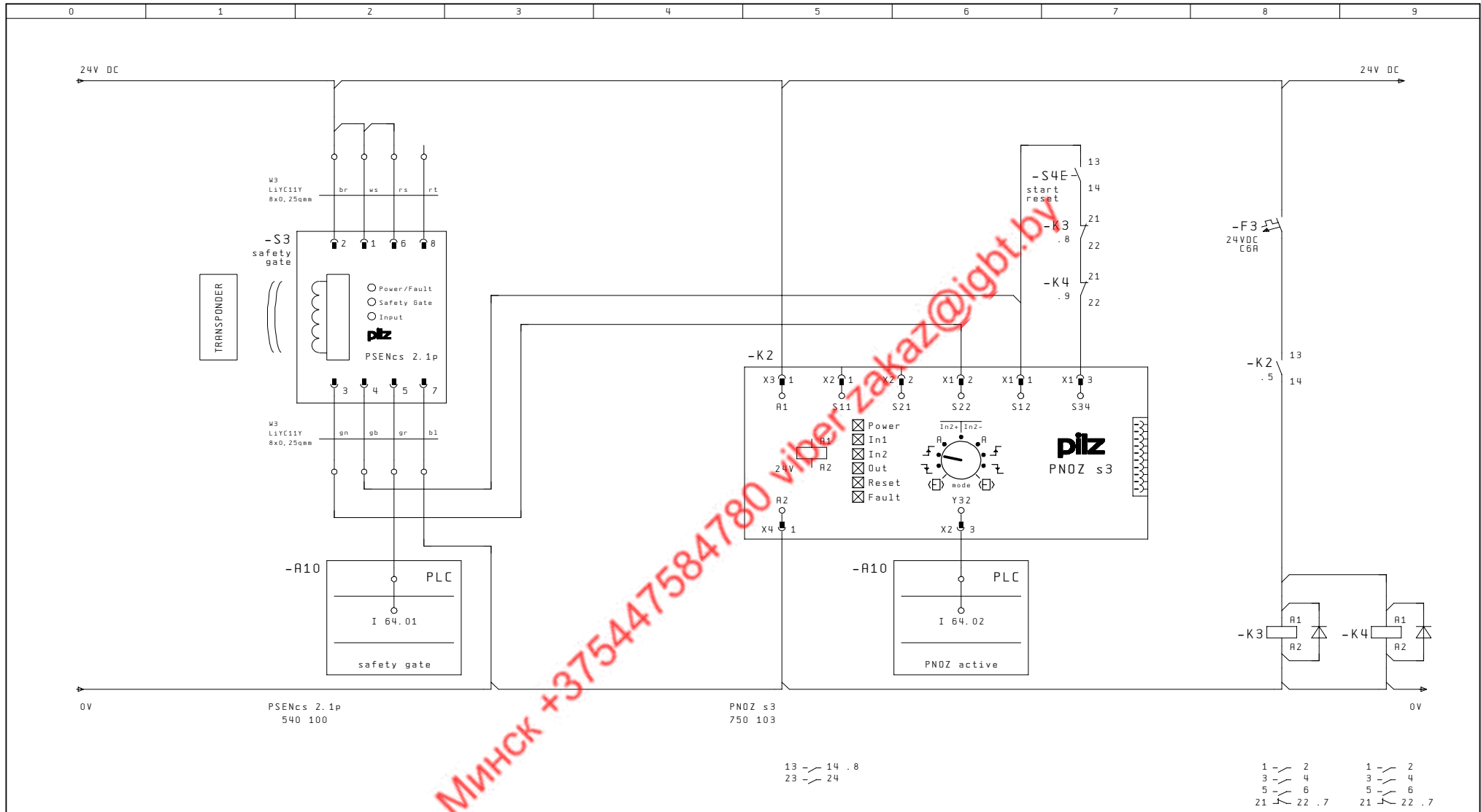

МИНСК +375447584780 viberzakaz@igbt.by

Revision	08.03.06	Date	07.12.05	Safety gate application	Pilz GmbH & Co. KG Felix-Wankel-Str. 2 73760 Ostfildern	Safety gate with PSEN cs2.1p and monitored start of PNOZ s3	Directory:
Name	WED	Name	WED				.. PNOZ\05PIL013
		Dep.	CS	Category 4 EN 954-1			PNOZs3
							Page: 2

МИНСК +375447584780 viber zakaz@igbt.by

## Category 3, EN 954-1 PNOZ s4 - Connecting four PSEN 1.1p in series

### Features

- ▶ Dual-channel operation with detection of shorts across contacts
- ▶ Series connection of 4 PSEN 1.1p safety switches using the PSEN ix1 interface
- ▶ Monitored reset with rising edge
- ▶ Contact expansion through positive-guided contactors
- ▶ Feedback loop to monitor contact expansion
- ▶ Up to Category 3 of EN 954-1

### Description

#### Safety gate function

The opening and closing of several safety gates is signalled to the safety relay PNOZ s4 (K8) via the contacts on the safety switches PSEN 1.1p (S6 ... S9). The PSEN ix1 interface (A2) switches the 4 safety switches in series.

The contacts on one of the safety switches S6 ... S9 are opened as soon as the respective safety gate is opened. The interface PSEN ix1 (A2) interrupts the input circuit on the safety relay PNOZ s4 (K8) and the safety contacts on K8 open. Contactors K14 and K15 de-energise.

### Settings on the unit

- ▶ The terminator on the PNOZ s4 must be connected.
- ▶ The operating mode selector switch (mode) on the safety relay PNOZ s4 must be set to "Monitored reset, rising edge" with detection of shorts across contacts (In2-).

### Start/reset

The safety relay PNOZ s4 (K8) can be started by pressing reset button S5 if:

- ▶ The safety gates are closed and
- ▶ The contacts on safety switches S6 ... S9 are closed and
- ▶ Contactors K14 and K15 have de-energised.

### Feedback loop

The positive-guided N/C contacts on contactors K14 and K15 are monitored in feedback loop S12-S34 of safety relay K8.

### Safety assessment

- ▶ The safety relay PNOZ s4 (K8) and contactors K14 and K15 must be installed in a single mounting area (control cabinet) in order to exclude a short across the output.
- ▶ Earth faults and shorts between contacts in the input circuit are detected.
- ▶ A fault on the device does not lead to the loss of the safety function.

- ▶ The safety relay PNOZ s4 (K8) can be started when the input circuit at K8 is closed first, followed by reset button S5. This avoids an unwanted reset before the input circuit is closed or as a result of the reset button being overridden.
- ▶ Not all faults are detected. An accumulation of undetected faults can lead to the loss of the safety function. With this application, therefore, it is necessary to ensure that only one safety gate is open at a time or that the status of each safety gate is checked. Use of the PSEN ix1 interface reduces the

- classification in accordance with EN 60947-5-3 from PDF-M to PDF-S.
- ▶ If the position of the operating mode selector switch (mode) is changed during operation, an error message will be triggered; the safety contacts on K8 open. This fault condition can only be rectified by switching the supply voltage on the safety relay K8 off and then on again.

### Pilz products

Number	Designation	Order number
1	PNOZ s4	750 104
4	PSEN 1.1p	504 212
1	PSEN ix1	535 120

## Category 3, EN 954-1

### PNOZ s4 - Connecting four PSEN 1.1p in series

#### Safety-related characteristics in accordance with EN 62061: 2005

- ▶ Safety-related control function (SRCF): Shut down machine when a safety gate is opened
- ▶ Subsystems: Input device (PSENmag), logic (PSEN ix1 + PNOZ s4), actuator (contactors K14 and K15)
- ▶ Safety integrity level: **SIL 2**
- ▶ SIL information only applies under the following conditions\*:
  - Common cause failure (CCF):  $\beta = 10 \%$
  - Proof test interval: 20 years
  - Operating interval (electromechanical components): Two operations per hour for input device and actuator
  - Contactors K14/K15 - characteristic data:  $B10_d: 2,000,000$ ; dangerous failure rate: 65 %

#### Safety-related characteristics in accordance with EN ISO 13849-1: 2006

- ▶ Safety function: Shut down machine when a safety gate is opened
- ▶ Safety-related parts of the control system (SRP/CS): Input device (PSENmag), logic (PSEN ix1 + PNOZ s4), actuator (contactors K14 and K15)
- ▶ Performance level: **PL d**
- ▶ PL information only applies under the following conditions\*:
  - Common cause failure (CCF): Requirements are considered to be met (must be tested on implementation)
  - Proof test interval: 20 years
  - Operating interval (electromechanical components): Two operations per hour for input device and actuator
  - Contactors K14/K15 - characteristic data:  $B10_d: 2,000,000$ ; dangerous failure rate: 65 %

\* Further requirements of EN 62061 and EN ISO 13849-1 have also to be met (e.g. requirements for systematic safety integrity and avoiding systematic faults, among others).

Минск +375 29 7584780 fiber@kaz@igt.by

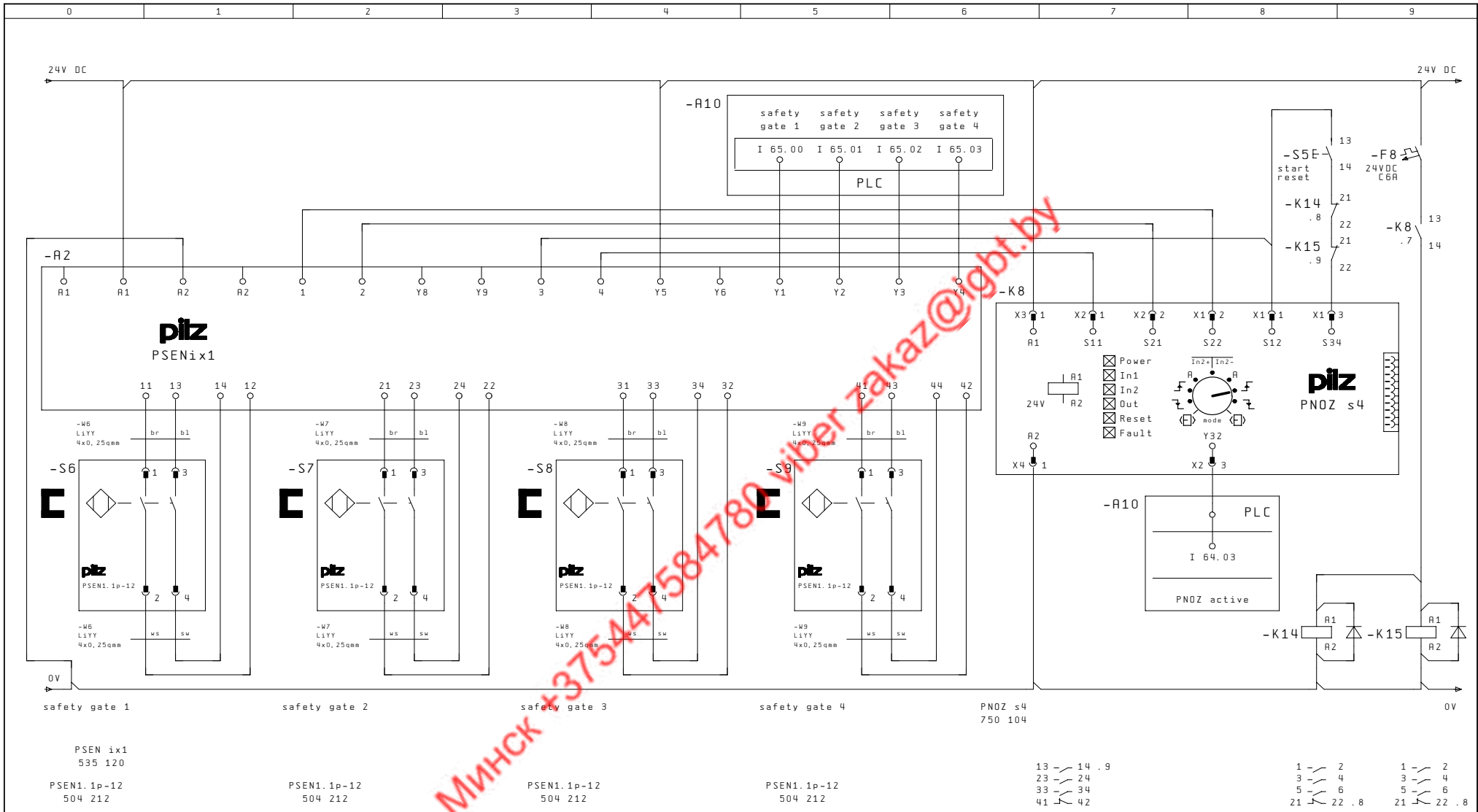

Revision	14.03.06	Date	07.12.05	Safety gate application	Pilz GmbH & Co. KG Felix-Wankel-Str. 2 73760 Ostfildern	Series connection by 4 safety gates with PSEN 1.1p and PSEN ix1	Directory:
Name	WED	Name	WED				... PNOZ\05PIL013
		Dep.	CS	Category 3 EN 954-1			PNOZ s4
							Page: 4

МИНСК +375447584780 viber zakaz@igbt.by

## Category 4, EN 954-1 PNOZ s4 - PSEN me2/2AS

### Features

- ▶ Dual-channel operation with detection of shorts across contacts
- ▶ Safety gate switch with separate actuator
- ▶ Automatic reset
- ▶ Contact expansion through positive-guided contactors
- ▶ Feedback loop to monitor contact expansion
- ▶ Up to Category 4 of EN 954-1

### Description

#### Safety gate function

The opening and closing of a safety gate is signalled to the safety relay PNOZ s4 (K9) via the contacts on the two safety switches PSEN me2/2AS (S11, S12).

The contacts on safety switches S11, S12 are opened as soon as the safety gate is opened. As a result the input circuit on the safety relay PNOZ s4 (K9) is interrupted and the safety contacts on K9 open. Contactors K10 and K11 de-energise.

#### Settings on the unit

- ▶ The terminator on the PNOZ s4 must be connected.
- ▶ The operating mode selector switch (mode) on the safety relay PNOZ s4 must be set to "Automatic reset" with detection of shorts across contacts (In2-).

### Start/reset

The safety relay PNOZ s4 (K9) starts automatically if

- ▶ The safety gate is closed and
- ▶ The contacts on safety switches S11 and S12 are closed and
- ▶ Contactors K10 and K11 have de-energised.

### Feedback loop

The positive-guided N/C contacts on contactors K10 and K11 are monitored in feedback loop S12-S34 of safety relay K9.

### Safety assessment

- ▶ The safety relay PNOZ s4 (K9) and contactors K10 and K11 must be installed in a single mounting area (control cabinet) in order to exclude a short across the output.
- ▶ Earth faults and shorts between contacts in the input circuit are detected.
- ▶ A fault on the device does not lead to the loss of the safety function.
- ▶ If the position of the operating mode selector switch (mode) is changed during operation, an error message will be triggered; the safety contacts on K9 open. This fault condition can only be rectified by switching the supply voltage on the safety relay K9 off and then on again.

### Pilz products

Number	Designation	Order number
1	PNOZ s4	750 104
2	PSEN me2/2AS	570 200

## Category 4, EN 954-1 PNOZ s4 - PSEN me2/2AS

### Safety-related characteristics in accordance with EN 62061: 2005

- ▶ Safety-related control function (SRCF): Shut down machine when a safety gate is opened
- ▶ Subsystems: Input device (PSENmech), logic (PNOZ s4), actuator (contactors K10 and K11)
- ▶ Safety integrity level: **SIL 3**
- ▶ SIL information only applies under the following conditions\*:
  - Common cause failure (CCF):  $\beta = 10 \%$
  - Proof test interval: 20 years
  - Operating interval (electromechanical components): Two operations per hour for input device and actuator
  - Contactors K10/K11 - characteristic data:  $B10_d: 2,000,000$ ; dangerous failure rate: 65 %

### Safety-related characteristics in accordance with EN ISO 13849-1: 2006

- ▶ Safety function: Shut down machine when a safety gate is opened
- ▶ Safety-related parts of the control system (SRP/CS): Input device (PSENmech), logic (PNOZ s4), actuator (contactors K10 and K11)
- ▶ Performance level: **PL e**
- ▶ PL information only applies under the following conditions\*:
  - Common cause failure (CCF): Requirements are considered to be met (must be tested on implementation)
  - Proof test interval: 20 years
  - Operating interval (electromechanical components): Two operations per hour for input device and actuator
  - Contactors K14/K15 - characteristic data:  $B10_d: 2,000,000$ ; dangerous failure rate: 65 %

\* Further requirements of EN 62061 and EN ISO 13849-1 have also to be met (e.g. requirements for systematic safety integrity and avoiding systematic faults, among others).

Минск +375447584780 viber zakaz@igt.by

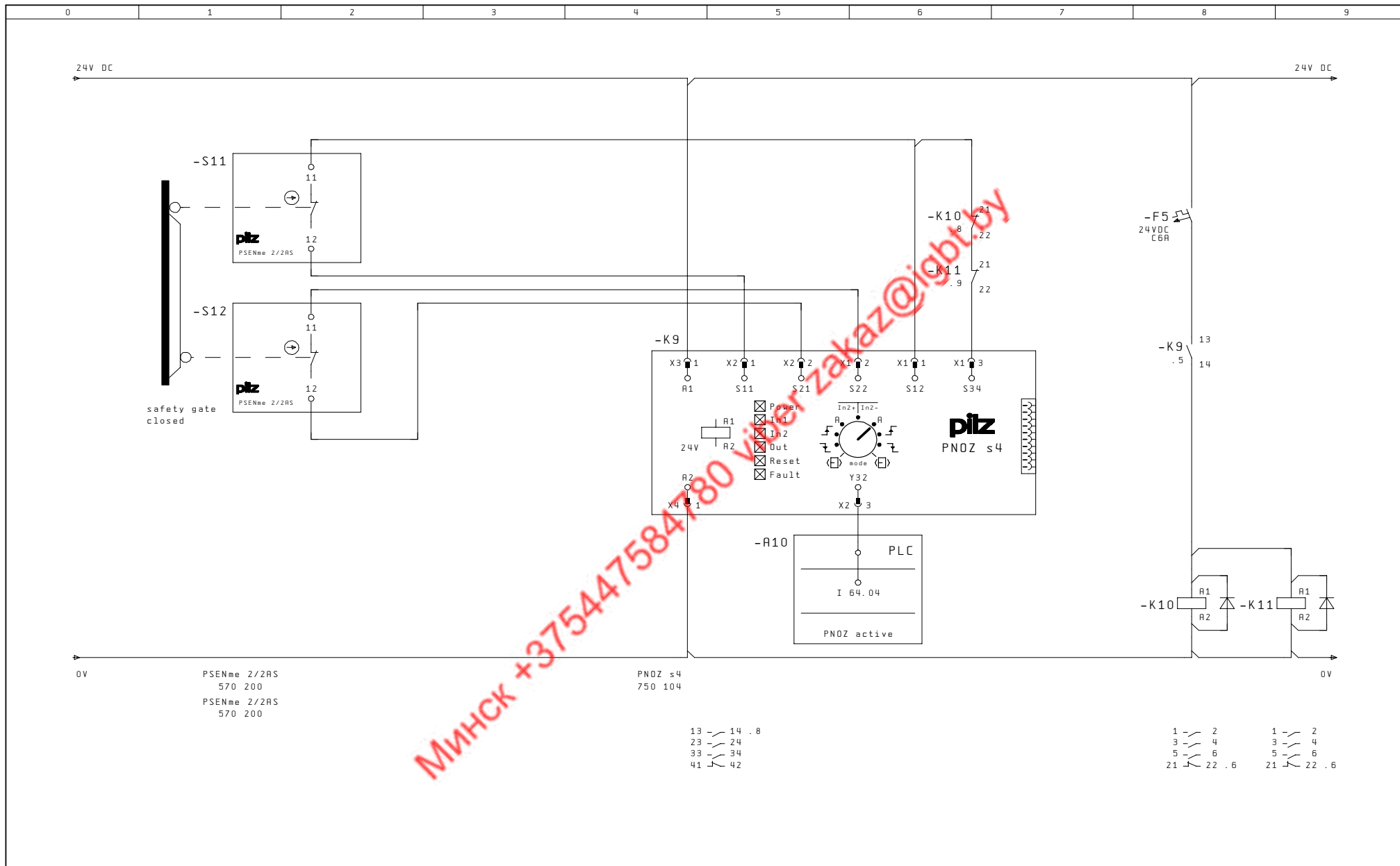

Revision	08.03.06	Date	07.12.05	Safety gate application	Pilz GmbH & Co. KG Felix-Wankel-Str. 2 73760 Ostfildern	Safety gate with two PSEN me2/2RS and automatic start of PNOZ s4	Directory:
Name	WED	Name	WED				.. PNOZ\05PIL013
		Dep.	CS	Category 4 EN 954-1			PNOZs4
							Page: 5

МИНСК +375447584780 viber zakaz@igbt.by

## Category 4, EN 954-1

### PNOZ s4 – PSEN me1S/1AS with guard locking and standstill monitoring

#### Features

- ▶ Dual-channel operation with detection of shorts across contacts
- ▶ Safety gate switch with separate actuator and guard locking device
- ▶ Second safety gate switch with separate actuator
- ▶ Monitored reset with rising edge
- ▶ Contact expansion through positive-guided contactors
- ▶ Standstill monitoring via PSWZ X1P
- ▶ Feedback loop to monitor contact expansion
- ▶ Up to Category 4 of EN 954-1

#### Description

##### Safety gate function

The opening and closing of a safety gate is signalled to the safety relay PNOZ s4 (K12) via the contacts on the safety switches PSENme 1S/1AS (S13) and PSENme 2/2AS (S14). Guard locking on safety switch S13 can be released via pushbutton S15. Guard locking will not be released until standstill monitor PSWZ X1P (K13) has detected that motor M1 is at standstill and the contacts at K13 are closed.

The contacts on safety switches S13 and S14 are opened as soon as the safety gate is opened. As a result the input circuit on the safety relay PNOZ s4 (K12) is interrupted and the safety contacts open. Contactors KM3 and KM4 de-energise.

When the simultaneity requirement of the

two input channels on the standstill monitor PSWZ X1P (K13) is exceeded, the unit switches to a fault condition. K13 is reactivated by pressing reset button S17.

##### Settings on the unit

- ▶ The terminator on the PNOZ s4 must be connected.
- ▶ The operating mode selector switch (mode) on the safety relay PNOZ s4 must be set to “Monitored reset, rising edge” with detection of shorts across contacts (In2-).

##### Start/reset

The safety relay PNOZ s4 (K12) can be started by pressing reset button S16 if:

- ▶ The safety gate is closed and
- ▶ The contacts on safety switches S13 and S14 are closed and
- ▶ Contactors KM3 and KM4 have de-energised.

##### Feedback loop

The positive-guided N/C contacts on contactors KM3 and KM4 are monitored in feedback loop S12-S34 of safety relay K12.

##### Safety assessment

- ▶ The safety relay PNOZ s4 (K12) and contactors KM3 and KM4 must be installed in a single mounting area (control cabinet) in order to exclude a short across the output.
- ▶ Earth faults and shorts between contacts in the input circuit are detected.
- ▶ A fault on the device does not lead to the loss of the safety function.
- ▶ The safety relay PNOZ s4 (K12) can be started when the input circuit at K12 is closed first, followed by reset button S16. This avoids an unwanted reset before the input circuit is closed or as a result of the reset button being overridden.

##### Pilz products

Number	Designation	Order number
1	PNOZ s4	750 104
1	PSWZ X1P	777 949
1	PSEN me1S/1AS	570 000
1	PSEN me2/2AS	570 200

- ▶ If the position of the operating mode selector switch (mode) is changed during operation, an error message will be triggered; the safety contacts on K12 open. This fault condition can only be rectified by switching the supply voltage on the safety relay K12 off and then on again.
- ▶ A break in the actuator on the safety switch PSEN me1S/1AS (S13) must be excluded.
- ▶ Fault avoidance measures must be taken to compensate for the lack of redundancy on the locking magnet on safety switch S13; these could include oversizing, protected cable layout, for example.

## Category 4, EN 954-1

### PNOZ s4 – PSEN me1S/1AS with guard locking and standstill monitoring

#### Safety-related characteristics in accordance with EN 62061: 2005

- ▶ Safety-related control function (SRCF): Shut down machine when a safety gate is opened
- ▶ Subsystems: Input device (PSENmech), logic (PNOZ s4), actuator (contactors KM3 and KM4)
- ▶ Safety integrity level: **SIL 3**
- ▶ SIL information only applies under the following conditions\*:
  - Common cause failure (CCF):  $\beta = 10 \%$
  - Proof test interval: 20 years
  - Operating interval (electromechanical components): Two operations per hour for input device and actuator
  - Contactor KM3/KM4 - characteristic data:  $B10_d: 2,000,000$ ; dangerous failure rate: 65 %

#### Safety-related characteristics in accordance with EN ISO 13849-1: 2006

- ▶ Safety function: Shut down machine when a safety gate is opened
- ▶ Safety-related parts of the control system (SRP/CS): Input device (PSENmech), logic (PNOZ s4), actuator (contactors KM3 and KM4)
- ▶ Performance level: **PL e**
- ▶ PL information only applies under the following conditions\*:
  - Common cause failure (CCF): Requirements are considered to be met (must be tested on implementation)
  - Proof test interval: 20 years
  - Operating interval (electromechanical components): Two operations per hour for input device and actuator
  - Contactor KM3/KM4 - characteristic data:  $B10_d: 2,000,000$ ; dangerous failure rate: 65 %

\* Further requirements of EN 62061 and EN ISO 13849-1 have also to be met (e.g. requirements for systematic safety integrity and avoiding systematic faults, among others).

Минск +375447584780 viber zakaz@igt.by

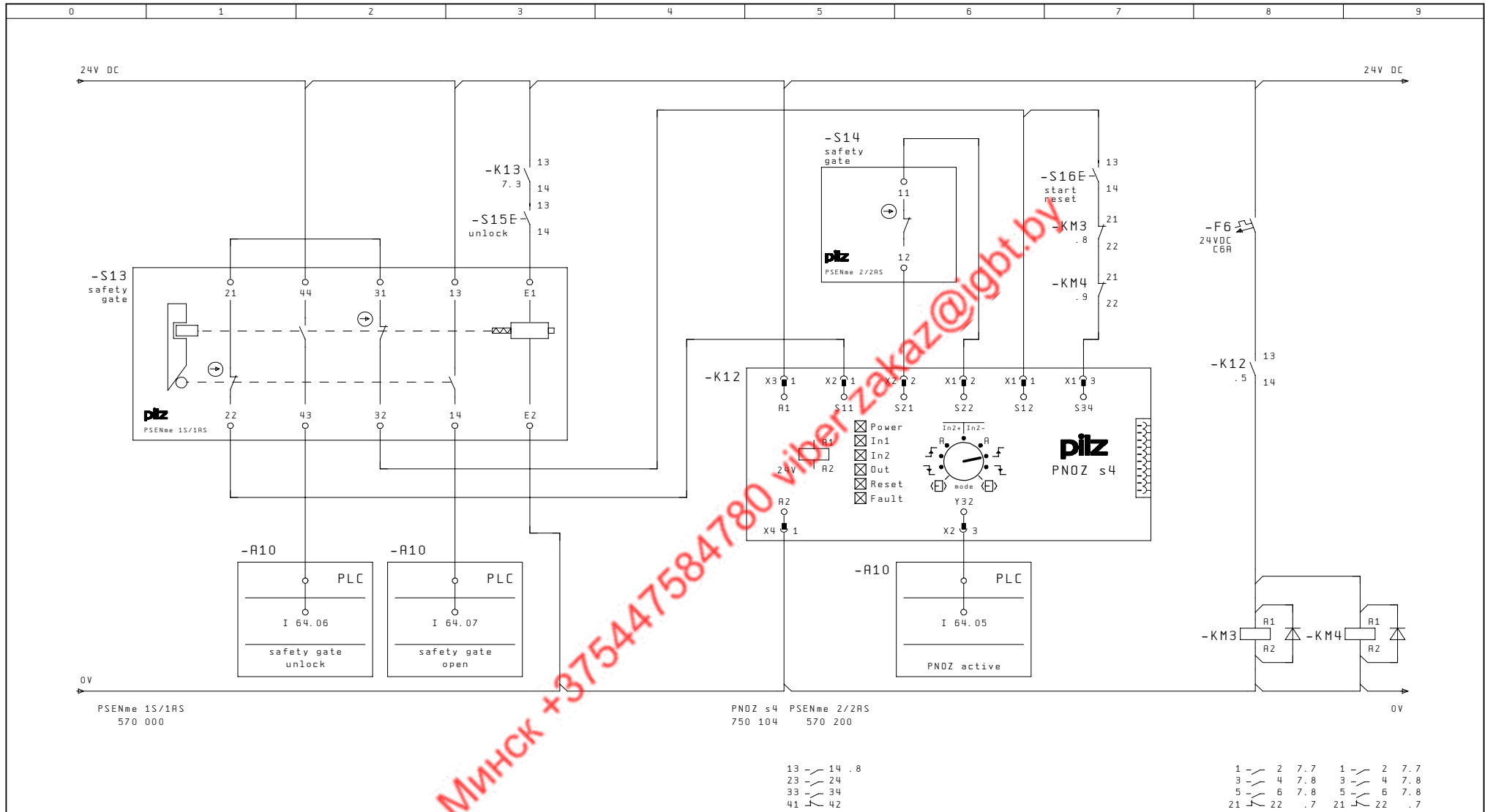

Revision	08.03.06	Date	07.12.05	Safety gate application	Pilz GmbH & Co. KG Felix-Wankel-Str. 2 73760 Ostfildern	Safety gate with PSEN me1S/1RS+PSEN me2/2RS standstill monitoring and monitored start of PNOZ s4	Directory:
Name	WED	Name	WED				.. PNOZ\05PIL013
		Dep.	CS	Category 4 EN 954-1			PNOZs4
							Page: 6

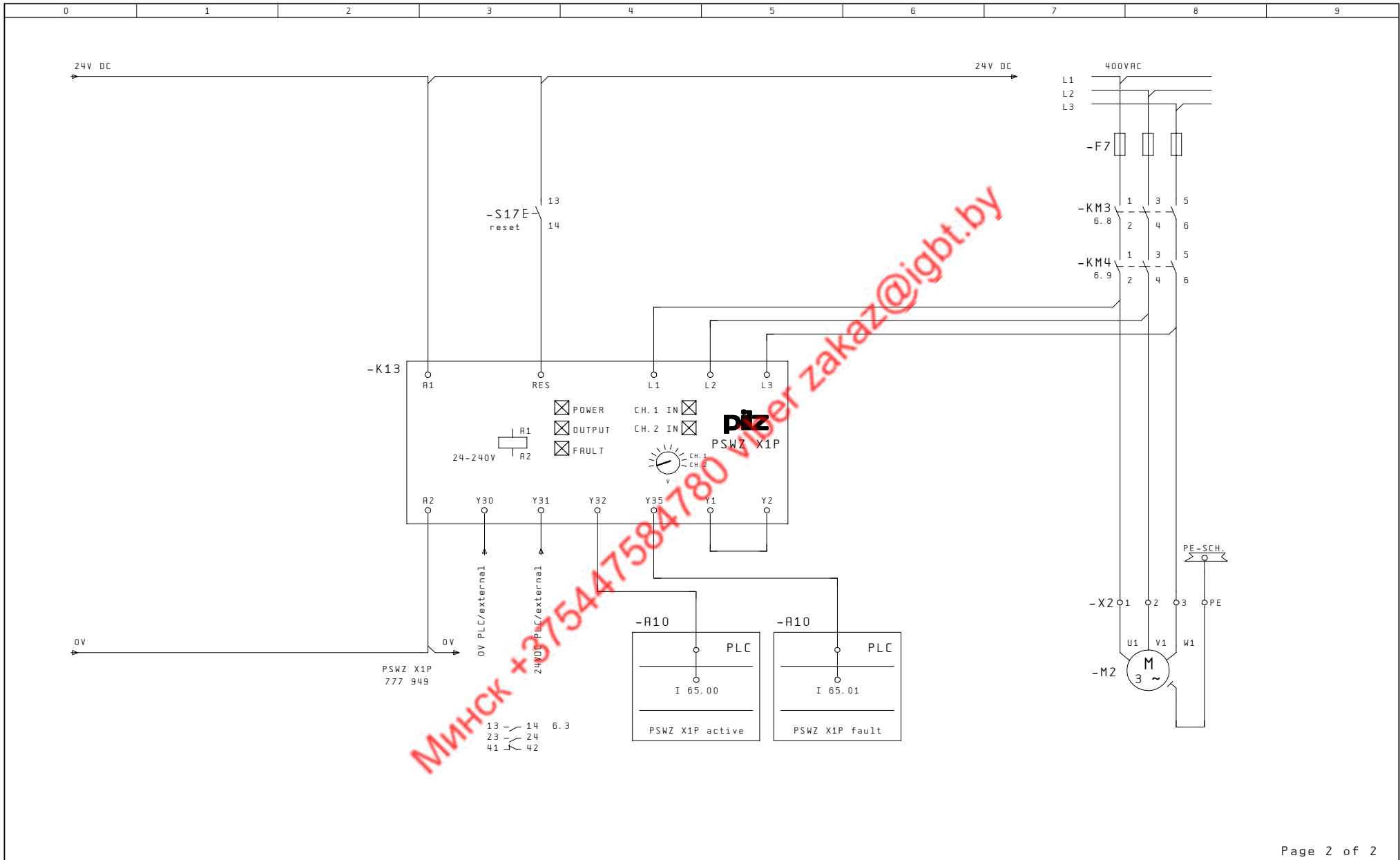

Revision	08.03.06	Date	07.12.05	Safety gate application	 Pilz GmbH & Co. KG Felix-Wankel-Str. 2 73760 Ostfildern	Safety gate with PSEN me1S/1AS standstill monitoring and monitored start of PNOZ s4	Directory:
Name	WED	Name	WED				Category 4 EN 954-1
		Dep.	CS				PNOZs4
							Page: 7

## Category 4, EN 954-1

### PNOZ s9 – PSEN me1S/1AS with guard locking and PSEN me2/2AS

#### Features

- ▶ Dual-channel operation with detection of shorts across contacts
- ▶ Safety gate switch with separate actuator and guard locking device
- ▶ Second safety gate switch with separate actuator
- ▶ Monitored reset
- ▶ Contact expansion through positive-guided contactors
- ▶ Feedback loop to monitor contact expansion
- ▶ Up to Category 4 of EN 954-1

#### Description

##### Safety gate function

The opening and closing of a safety gate is signalled to the safety relay PNOZ X3P (K1) via the contacts on the safety switches PSEN me2/2AS (S1) and PSEN me1S/1AS (S10). Guard locking on safety switch S10 can be released via pushbutton S2. Guard locking will not be released until the safety contacts on the contact expander module PNOZ s9 (K2) are closed (delay-on energisation).

The contacts on the safety switch S10 are opened as soon as the guard locking is released via pushbutton S2. The contacts on the two safety switches S1 and S10 are opened as soon as the safety gate is opened. As a result the input circuit on the safety relay PNOZ X3P (K1) is interrupted and the safety contacts on K1 open.

Contactors K3 and K4 de-energise.

The input circuit S32 on safety relay PNOZ s9 (K2) is closed as soon as “Stop button” S21 is operated, contactor K20 has de-energised and the N/C contact (21-22) on K20 is closed again. Once the set delay time has elapsed, safety contact (17-18) on the contact expander module PNOZ s9 (K2) will close. Guard locking on safety switch S10 can then be released via pushbutton S2.

##### Settings on the unit

- ▶ The terminator on the PNOZ s9 must be connected.
- ▶ The operating mode selector switch (mode) on the contact expander module PNOZ s9 must be set to “Delay-on energisation”.
- ▶ The delay time on the safety relay PNOZ s9 is set using the time selector switch t[s] and the factor selector switch n.

##### Start/reset

The safety relay PNOZ X3P (K1) can be started by pressing reset button S3 if:

- ▶ The safety gate is closed and
- ▶ The contacts on safety switches S1 and S10 are closed and
- ▶ Contactors K3 and K4 have de-energised.

The contact expander module PNOZ s9 (K2) starts automatically if

- ▶ Contactor K20 has de-energised.

##### Feedback loop

The positive-guided N/C contacts on contactors K3 and K4 are monitored in the safety relay’s feedback circuit S33-S34.

##### Safety assessment

- ▶ The safety relay PNOZ X3P (K1) and contactors K3 and K4 must be installed in a single mounting area (control cabinet) in order to exclude a short across the output.
- ▶ Earth faults and shorts between contacts in the input circuit are detected.
- ▶ A fault on the device does not lead to the loss of the safety function.
- ▶ The safety relay PNOZ X3P can be started when the input circuit at K1 is closed first, followed by the reset button S3. This avoids an unwanted reset before the input circuit is closed or as a result of the reset button being overridden.
- ▶ If the position of the operating mode selector switch (mode) or the rotary switch for the time setting is changed during operation, an error message will be triggered; the safety contacts on K2 open. This fault condition can only be rectified by switching the supply voltage on the safety relay K2 off and then on again.
- ▶ A break in the actuator on the safety switch PSEN me1S/1AS (S10) must be excluded.
- ▶ Fault avoidance measures must be taken to compensate for the lack of redundancy on the locking magnet on safety switch S10; these could include oversizing, protected cable layout, for example.

##### Pilz products

Number	Designation	Order number
1	PNOZ s9	750 109
1	PSEN me1S/1AS	570 000
1	PSEN me2/2AS	570 200
1	PNOZ X3P	777 310

## Category 4, EN 954-1

### PNOZ s9 – PSEN me1S/1AS with guard locking and PSEN me2/2AS

#### Safety-related characteristics in accordance with EN 62061: 2005

- ▶ Safety-related control function (SRCF): Shut down machine when a safety gate is opened
- ▶ Subsystems: Input device (PSENmech), logic (PNOZ X3P), actuator (contactors K3 and K4)
- ▶ Safety integrity level: **SIL 3**
- ▶ SIL information only applies under the following conditions\*:
  - Common cause failure (CCF):  $\beta = 10 \%$
  - Proof test interval: 20 years
  - Operating interval (electromechanical components): Two operations per hour for input device and actuator
  - Contactor K3/K4 - characteristic data:  $B10_d: 2,000,000$ ; dangerous failure rate: 65 %

#### Safety-related characteristics in accordance with EN ISO 13849-1: 2006

- ▶ Safety function: Shut down machine when a safety gate is opened
- ▶ Safety-related parts of the control system (SRP/CS): Input device (PSENmech), logic (PNOZ X3P), actuator (contactors K3 and K4)
- ▶ Performance level: **PL e**
- ▶ PL information only applies under the following conditions\*:
  - Common cause failure (CCF): Requirements are considered to be met (must be tested on implementation)
  - Proof test interval: 20 years
  - Operating interval (electromechanical components): Two operations per hour for input device and actuator
  - Contactor K3/K4 - characteristic data:  $B10_d: 2,000,000$ ; dangerous failure rate: 65 %

\* Further requirements of EN 62061 and EN ISO 13849-1 have also to be met (e.g. requirements for systematic safety integrity and avoiding systematic faults, among others).

МИНСК +375447684780 viber zakaz@igt.by

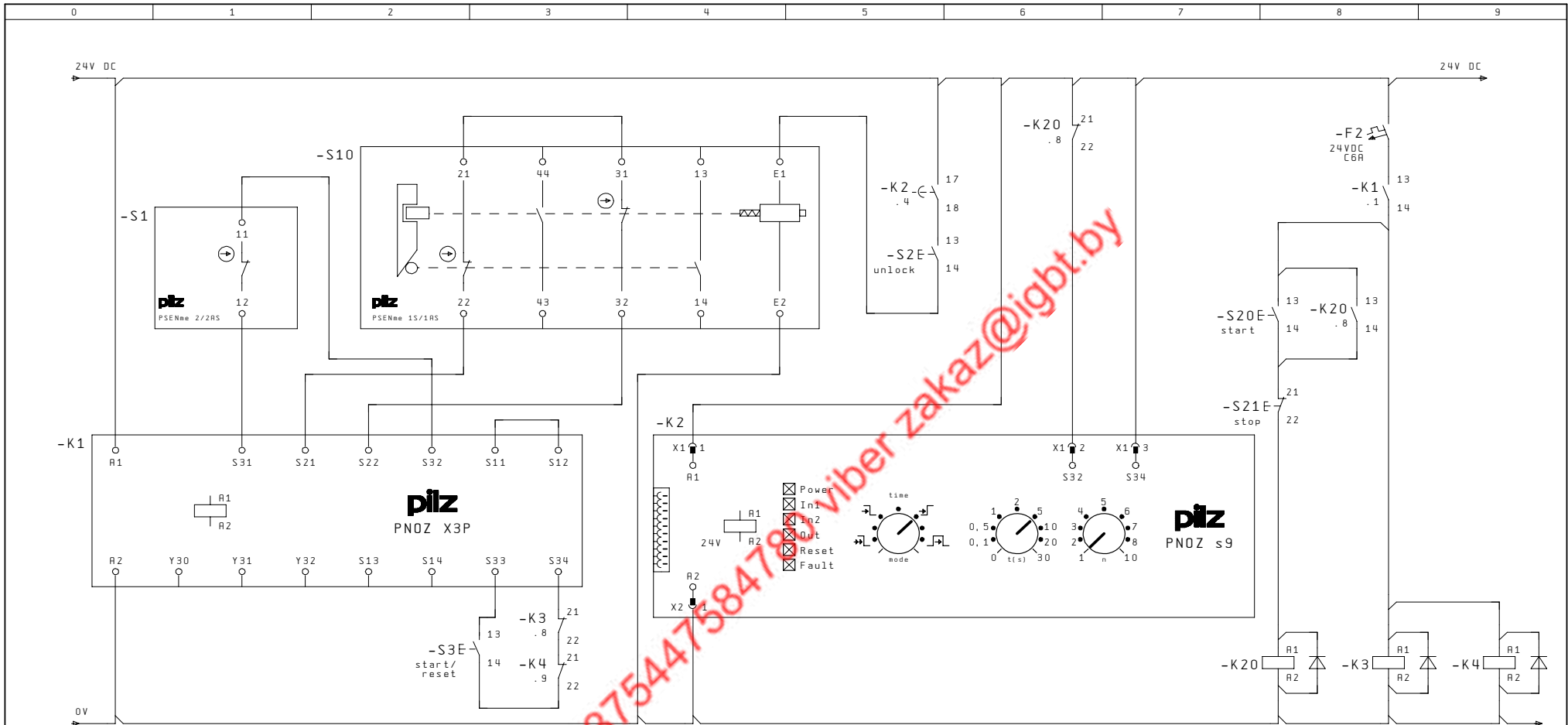

PNOZ X3P  
777 310  
PSENme 2/2RS  
570 200

PSENme 1S/1RS  
570 000

PNOZ s9  
750 109

13 - 14 .8  
23 - 24  
33 - 34  
41 - 42

17 - 18 .5  
27 - 28  
37 - 38  
45 - 46

11 - 12  
13 - 14 .8  
21 - 22 .6  
23 - 24  
1 - 2  
3 - 4  
5 - 6  
21 - 22 .3  
1 - 2  
3 - 4  
5 - 6  
21 - 22 .3

Revision	Z1.03.06	Date	07.12.05	Safety gate application	Pilz GmbH & Co. KG Felix-Wankel-Str. 2 73760 Ostfildern	Safety gate with PSENme 1S/1RS unlocking time-delayed	Directory:
Name	WED	Name	WED				Category 4 EN 954-1
		Dep.	CS				PNOZs9
							Page: 1

МИНСК +375447584780 viber zakaz@igbt.by

<b>Contents</b>		<b>Page</b>
<b>ESPE applications</b>		
PNOZ s4	- PSEN op4H light curtain	Category 4* 1.3-2

\* in accordance with EN 954-1

МИНСК +375447584780 viber zakaz@igbt.by

## Category 4, EN 954-1 PNOZ s4 - PSEN op4H light curtain

### Features

- ▶ Dual-channel operation with detection of shorts across contacts via light curtain
- ▶ Monitored reset with rising edge
- ▶ Light curtain with semiconductor output
- ▶ Contact expansion through positive-guided contactors
- ▶ Feedback loop to monitor contact expansion
- ▶ Up to Category 4 of EN 954-1

### Description

#### Light curtain function

The interruption of light curtain PSEN op4H (B1/B2) is signalled to the safety relay PNOZ s4 (K2) via the two semiconductor outputs on receiver B2.

The semiconductor outputs on the safety light curtain's receiver B2 are opened as soon as the light curtain is interrupted. As a result the input circuit on the safety relay PNOZ s4 (K2) is interrupted and the safety contacts open. Contactors K3 and K4 de-energise.

The top and bottom DIP switches on the receiver B2 must be set at the same position. For the light curtain to reset automatically, number 4 on both DIP switches must be switched to ON.

#### Settings on the unit

- ▶ The terminator on the PNOZ s4 must be connected.
- ▶ The operating mode selector switch (mode) on the safety relay PNOZ s4 must be set to "Monitored reset, rising edge" without detection of shorts across contacts (In2+).

#### Start/reset

The safety relay PNOZ s4 (K2) can be started by pressing reset button S3 if:

- ▶ The light curtain is not interrupted and
- ▶ The semiconductor outputs on safety light curtain B1/B2 are closed and
- ▶ Contactors K3 and K4 have de-energised.

#### Feedback loop

The positive-guided N/C contacts on contactors K3 and K4 are monitored in feedback loop S12-S34 of the safety relay.

#### Safety assessment

- ▶ The safety relay PNOZ s4 (K2) and contactors K3, K4 must be installed in a single mounting area (control cabinet) in order to exclude a short across the output.
- ▶ Earth faults and shorts between contacts in the input circuit are detected via the light curtain.
- ▶ A fault on the device does not lead to the loss of the safety function.
- ▶ A single fault in the light curtain is detected.

- ▶ The safety relay PNOZ s4 (K2) can be started when the input circuit at K2 is closed first, followed by reset button S3. This avoids an unwanted reset before the input circuit is closed or as a result of the reset button being overridden.

- ▶ If the position of the operating mode selector switch (mode) is changed during operation, an error message will be triggered; the safety contacts on K2 open. This fault condition can only be rectified by switching the supply voltage on the safety relay K2 off and then on again.

#### Pilz products

Number	Designation	Order number
1	PNOZ s4	750 104
1	PSEN op4H-30-150	630 159

## Category 4, EN 954-1

### PNOZ s4 - PSEN op4H light curtain

#### Safety-related characteristics in accordance with EN 62061: 2005

- ▶ Safety-related control function (SRCF): Shut down the machine when the safety light curtain is interrupted
- ▶ Subsystems: Input device (PSEN op4H), logic (PNOZ s4), actuator (contactors K3 and K4)
- ▶ Safety integrity level: **SIL 3**
- ▶ SIL information only applies under the following conditions\*:
  - Common cause failure (CCF):  $\beta = 10 \%$
  - Proof test interval: 20 years
  - Operating interval (electromechanical components): Two operations per hour for actuator
  - Contactor K3/K4 - characteristic data:  $B10_d: 2,000,000$ ; dangerous failure rate: 65 %

#### Safety-related characteristics in accordance with EN ISO 13849-1: 2006

- ▶ Safety function: Shut down the machine when the safety light curtain is interrupted
- ▶ Safety-related parts of the control system (SRP/CS): Input device (PSEN op4H), logic (PNOZ s4), actuator (contactors K3 and K4)
- ▶ Performance level: **PL e**
- ▶ PL information only applies under the following conditions\*:
  - Common cause failure (CCF): Requirements are considered to be met (must be tested on implementation)
  - Proof test interval: 20 years
  - Operating interval (electromechanical components): Two operations per hour for actuator
  - Contactor K3/K4 - characteristic data:  $B10_d: 2,000,000$ ; dangerous failure rate: 65 %

\* Further requirements of EN 62061 and EN ISO 13849-1 have also to be met (e.g. requirements for systematic safety integrity and avoiding systematic faults, among others).

Минск +375447584780 viber zakaz@igb.by

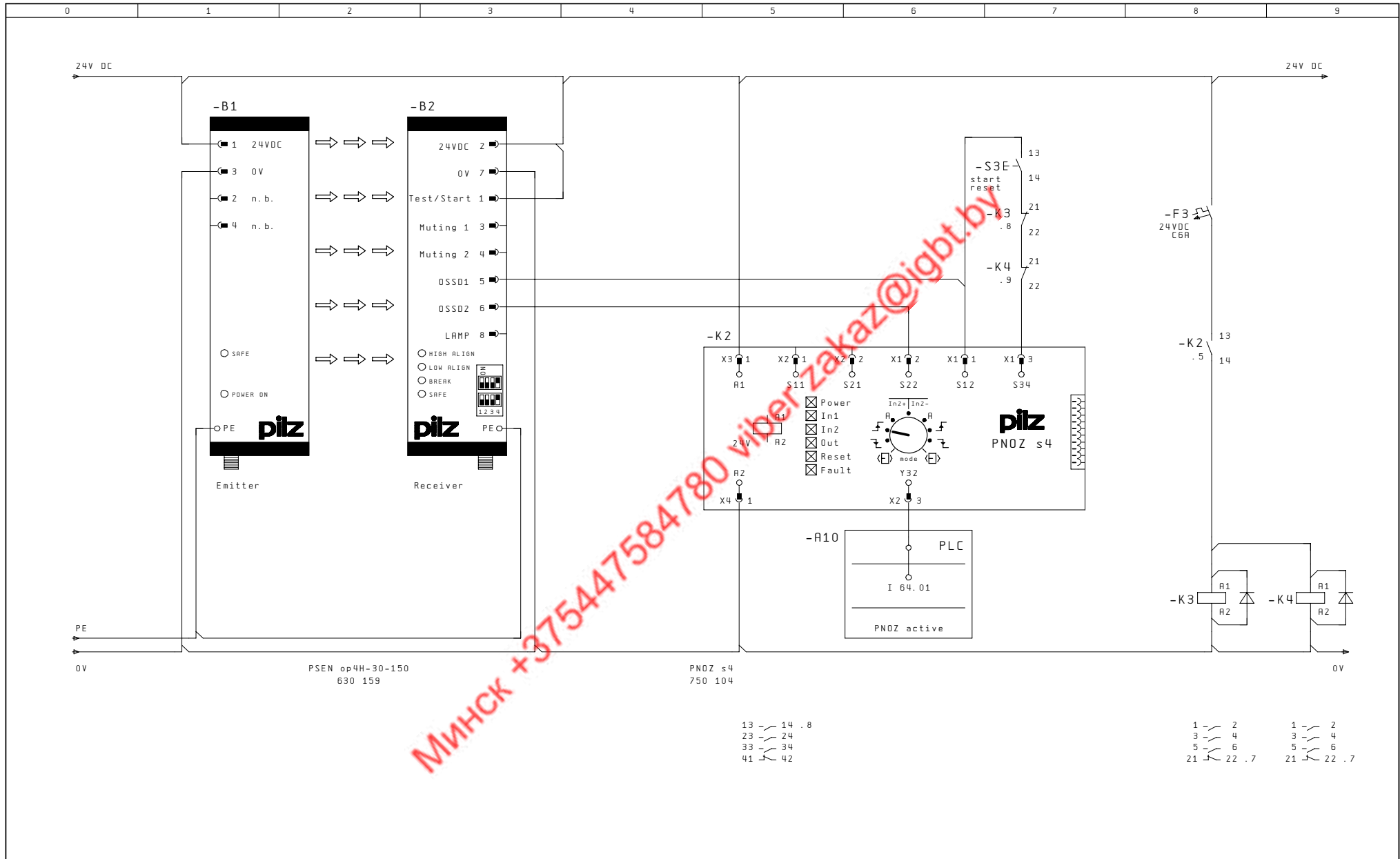

МИНСК +375447584780 viberzakaz@igbt.by

Revision	08.03.06	Date	07.12.05	ESPE application	 Pilz GmbH & Co. KG Felix-Wankel-Str. 2 73760 Ostfildern	ESPE PSEN op4H with monitored start of PNOZ s4	Directory:
Name	WED	Name	WED				.. PNOZ\05PIL013
		Dep.	CS	Category 4 EN 954-1			PNOZs4
							Page: 2

<b>Contents</b>		<b>Page</b>
<b>Further applications</b>		
PNOZ s6	- Requirements in accordance with EN 574 Type IIIC, Contact expansion through contactors	Category 4 1.4-2
PNOZ s6	- Requirements in accordance with EN 574 Type IIIC, Contact expansion through PNOZ s10	Category 4 1.4-6
PNOZ s6.1	- Requirements in accordance with EN 574 Type IIIA	Category 1 1.4-10

Минск +375447584780 viber zalo@pilot.by

## Category 4, EN 954-1

### PNOZ s6 - Requirements in accordance with EN 574 Type IIIC, contact expansion through contactors

#### Features

- ▶ Dual-channel operation with detection of shorts across contacts
- ▶ Simultaneity monitoring
- ▶ Contact expansion through positive-guided contactors
- ▶ Feedback loop to monitor contact expansion
- ▶ Requirements in accordance with EN 574 Type IIIC
- ▶ Up to Category 4 of EN 954-1

#### Description

#### Function

The two-hand control device PNOZ s6 (K1) is activated by operating both pushbuttons S1 and S2 simultaneously (simultaneity max. 500 ms), the safety contacts on K1 close. Contactors KM1 and KM2 energise. Releasing one or both pushbuttons S1 / S2 will interrupt the input circuit on the two-hand control device K1, the safety contacts at K1 open. Contactors KM1 and KM2 de-energise. The safety contacts on the two-hand control device PNOZ s6 (K1) will not reclose until both pushbuttons S1 and S2 have been released and then re-operated simultaneously.

#### Settings on the unit

The terminator on the PNOZ s6 must be connected.

#### Start/reset

The two-hand control device PNOZ s6 can be started by operating pushbuttons S1 and S2 simultaneously when contactors KM1 and KM2 have de-energised.

#### Feedback loop

The positive-guided N/C contacts on contactors KM1 and KM2 are monitored in feedback loop S12-S34 of the two-hand control device.

#### Safety assessment

- ▶ The two-hand control device PNOZ s6 (K1) and contactors KM1 and KM2 must be installed in a single mounting area (control cabinet) in order to exclude a short across the output.
- ▶ Earth faults and shorts between contacts in the input circuit are detected.
- ▶ A fault on the device does not lead to the loss of the safety function.

- ▶ The distance of both pushbuttons S1 and S2 from the nearest danger zone must be large enough that if one of the pushbuttons is released, the dangerous movement is interrupted before the operator can reach the danger zone or before the operator can reach into the danger zone (see EN 999 „The positioning of protective equipment in respect of approach speeds of parts of the human body“).

#### Pilz products

Number	Designation	Order number
1	PNOZ s6	750 106

## Category 4, EN 954-1

### PNOZ s6 - Requirements in accordance with EN 574 Type IIIC, contact expansion through contactors

#### Safety-related characteristics in accordance with EN 62061: 2005

- ▶ Safety-related control function (SRCF):  
If the output signal from a two-hand circuit shuts down in accordance with EN 574 Type IIIC, the actuator technology for shutting down a hazardous movement must shut down.
- ▶ Subsystems:  
Input devices (pushbutton S1, pushbutton S2), logic (PNOZ s6), actuator (contactors KM1 and KM2)
- ▶ Safety integrity level:  
**SIL 3**
- ▶ SIL information only applies under the following conditions\*:
  - Common cause failure (CCF):  $\beta = 5 \%$  (note increased requirements)
  - Proof test interval: 20 years
  - Operating interval (electromechanical components): 60 operations per hour for input device and actuator
  - Pushbutton S1, S2 - characteristic data:  $B10_{gr}$ : 20,000,000; dangerous failure rate: 50 %
  - Contactors KM1/KM2 - characteristic data:  $B10_{gr}$ : 20,000,000; dangerous failure rate: 65 % (note oversizing)

#### Safety-related characteristics in accordance with EN ISO 13849-1: 2006

- ▶ Safety function:  
If the output signal from a two-hand circuit shuts down in accordance with EN 574 Type IIIC, the actuator technology for shutting down a hazardous movement must shut down.
- ▶ Safety-related parts of the control system (SRP/CS):  
Input devices (pushbutton S1, pushbutton S2), logic (PNOZ s6), actuator (contactors KM1 and KM2)
- ▶ Performance level:  
**PL e**
- ▶ PL information only applies under the following conditions\*:
  - Common cause failure (CCF): Requirements are considered to be met (must be tested on implementation)
  - Proof test interval: 20 years
  - Operating interval (electromechanical components): 60 operations per hour for input device and actuator
  - Pushbutton S1, S2 - characteristic data:  $B10_{gr}$ : 20,000,000; dangerous failure rate: 50 %
  - Contactors KM1/KM2 - characteristic data:  $B10_{gr}$ : 20,000,000; dangerous failure rate: 65 % (note oversizing)

\* Further requirements of EN 62061 and EN ISO 13849-1 have also to be met (e.g. requirements for systematic safety integrity and avoiding systematic faults, among others).

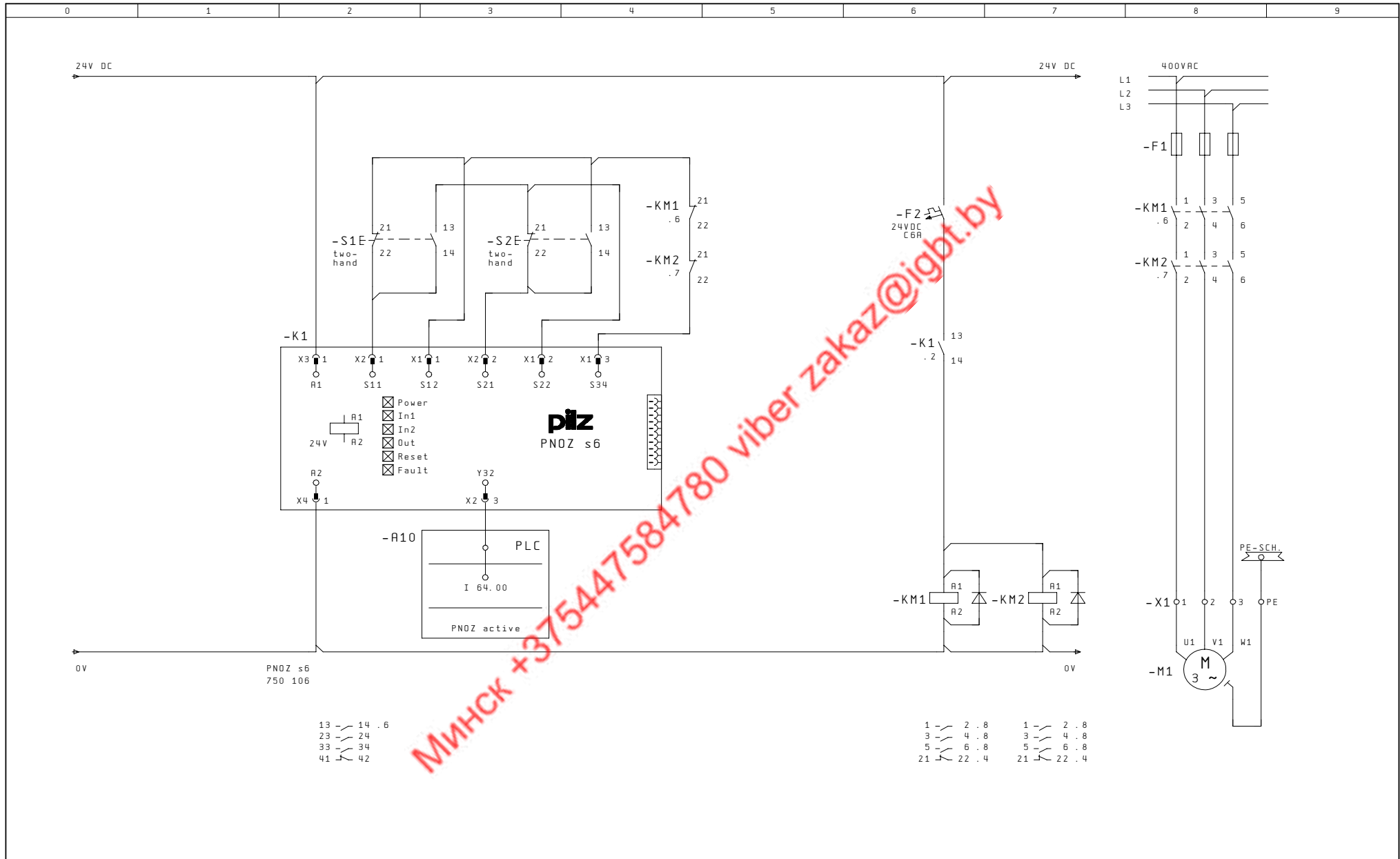

Revision	17.07.06	Date	07.12.05	Two-hand application	Pilz GmbH & Co. KG Felix-Wankel-Str. 2 73760 Ostfildern	Two-hand operation (request class 3C, EN 574) extension contact by contactors	Directory:
Name	WED	Name	WED				.. PNOZ\05PIL013
		Dep.	CS	Category 4 EN 954-1			PNOZs6
							Page: 1

МИНСК +375447584780 viber zakaz@igbt.by

## Category 4, EN 954-1

### PNOZ s6 - Requirements in accordance with EN 574 Type IIIC, contact expansion through PNOZ s10

#### Features

- ▶ Dual-channel operation with detection of shorts across contacts
- ▶ Simultaneity monitoring
- ▶ Contact expansion through PNOZ s10 (contact expander module)
- ▶ Feedback loop to monitor contact expansion
- ▶ Meets requirements in accordance with EN 574 Type IIIC
- ▶ Up to Category 4 of EN 954-1

#### Description

##### Function

The two-hand control device PNOZ s6 (K2) is activated by operating both pushbuttons S3 and S4 simultaneously (simultaneity max. 500 ms), the safety contacts on K2 close. The contact expander module PNOZ s10 (K3) is started.

Releasing one or both pushbuttons S3 / S4 will interrupt the input circuit on the two-hand control device K2, the safety contacts at K2 open. The contact expander module K3 shuts down. The safety contacts on the two-hand control device PNOZ s6 (K2) will not reclose until both pushbuttons S3 and S4 have been released and then re-operated simultaneously.

#### Settings on the unit

The connector between the safety relays PNOZ s6 (K2) and PNOZ s10 (K3) must be connected.

#### Start/reset

The two-hand control device PNOZ s6 can be started by operating pushbuttons S3 and S4 simultaneously when the feedback loop in the contact expander module PNOZ s10 (K3) is closed.

#### Feedback loop

The feedback loop on the safety relay PNOZ s6 (K2) is connected to the feedback loop on the contact expander module PNOZ s10 (K3).

#### Safety assessment

- ▶ Earth faults and shorts between contacts in the input circuit are detected.
- ▶ A fault on the device does not lead to the loss of the safety function.
- ▶ The distance of both pushbuttons S3 and S4 from the nearest danger zone must be large enough that if one of the pushbuttons is released, the dangerous movement is interrupted before the operator can reach the danger zone or before the operator can reach into the danger zone (see EN 999 „The positioning of protective equipment in respect of approach speeds of parts of the human body“).

#### Pilz products

Number	Designation	Order number
1	PNOZ s6	750 106
1	PNOZ s10	750 110

## Category 4, EN 954-1

### PNOZ s6 - Requirements in accordance with EN 574 Type IIIC, contact expansion through PNOZ s10

#### Safety-related characteristics in accordance with EN 62061: 2005

- ▶ Safety-related control function (SRCF):  
If the output signal from a two-hand circuit shuts down in accordance with EN 574 Type IIIC, the actuator technology for shutting down a hazardous movement must shut down.  
Input devices (pushbutton S3, pushbutton S4), logic (PNOZ s6), actuator (PNOZ s10)
- ▶ Subsystems:
- ▶ Safety integrity level:  
**SIL 3**
- ▶ SIL information only applies under the following conditions\*:
  - Common cause failure (CCF):  $\beta = 10 \%$
  - Proof test interval: 20 years
  - Operating interval (electromechanical components): 60 operations per hour for input device
  - Pushbutton S3, S4 - characteristic data:  $B10_g: 20,000,000$ ; dangerous failure rate: 50 %

#### Safety-related characteristics in accordance with EN ISO 13849-1: 2006

- ▶ Safety function:  
If the output signal from a two-hand circuit shuts down in accordance with EN 574 Type IIIC, the actuator technology for shutting down a hazardous movement must shut down.
- ▶ Safety-related parts of the control system (SRP/CS):  
Input devices (pushbutton S3, pushbutton S4), logic (PNOZ s6), actuator (PNOZ s10)
- ▶ Performance level:  
**PL e**
- ▶ PL information only applies under the following conditions\*:
  - Common cause failure (CCF): Requirements are considered to be met (must be tested on implementation)
  - Proof test interval: 20 years
  - Operating interval (electromechanical components): 60 operations per hour for input device
  - Pushbutton S3, S4 - characteristic data:  $B10_g: 20,000,000$ ; dangerous failure rate: 50 %

\* Further requirements of EN 62061 and EN ISO 13849-1 have also to be met (e.g. requirements for systematic safety integrity and avoiding systematic faults, among others).

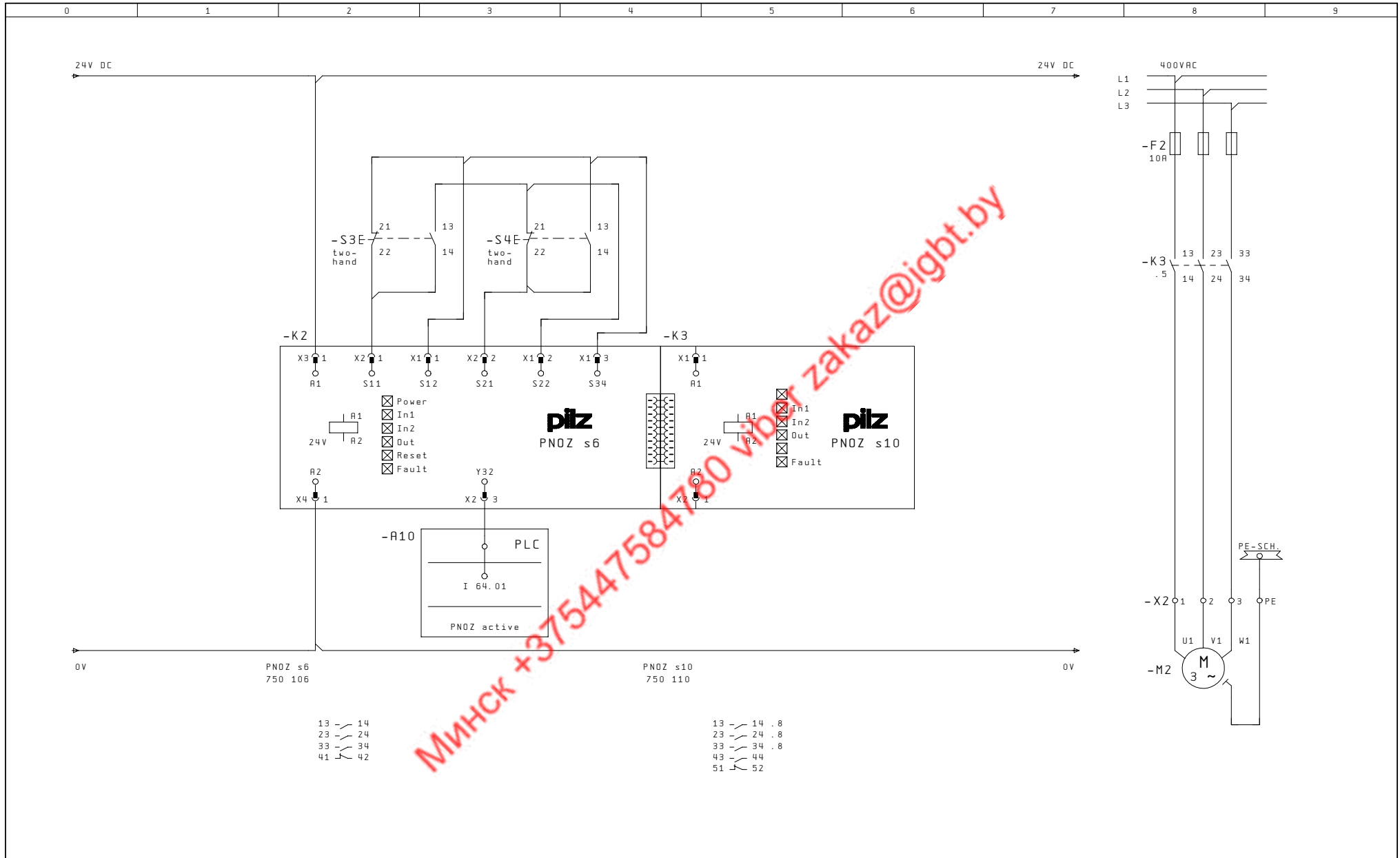

Revision	17.07.06	Date	07.12.05	Two-hand application	Pilz GmbH & Co. KG Felix-Wankel-Str. 2 73760 Ostfildern	Two-hand operation (request class 3C, EN 574) extension contact by PNOZ s10	Directory:
Name	WED	Name	WED				...PNOZ\05PIL013
		Dep.	CS	Category 4 EN 954-1			PNOZ s6
							Page: 2

МИНСК +375447584780 viber zakaz@igbt.by

## Category 1, EN 954-1

### PNOZ s6.1 - Requirements in accordance with EN 574 Type IIIA

#### Features

- ▶ Dual-channel operation
- ▶ Simultaneity monitoring
- ▶ Contact expansion through positive-guided contactor
- ▶ Feedback loop to monitor contact expansion
- ▶ Requirements in accordance with EN 574 Type IIIA
- ▶ Up to Category 1 of EN 954-1

#### Description

##### Function

The two-hand control device PNOZ s6.1 (K1) is activated by operating both pushbuttons S1 and S2 simultaneously (simultaneity max. 500 ms), the safety contacts on K1 close. Contactor KM1 energises.

Releasing one or both pushbuttons S1 / S2 will interrupt the input circuit on the two-hand control device K1, the safety contacts at K1 open. Contactor KM1 de-energises. The safety contacts on the two-hand control device PNOZ s6.1 (K1) will not reclose until both pushbuttons S1 and S2 have been released and then re-operated simultaneously.

##### Settings on the unit

The terminator on the PNOZ s6.1 must be connected.

#### Start/reset

The two-hand control device PNOZ s6.1 can be started by operating pushbuttons S1 and S2 simultaneously when contactor KM1 has de-energised.

#### Feedback loop

The positive-guided N/C contact on contactor KM1 is monitored in feedback loop S24-S34 of the two-hand control device K1.

#### Safety assessment

- ▶ Earth faults in the input circuit are detected.
- ▶ A fault on the device does not lead to the loss of the safety function.
- ▶ The distance of both pushbuttons S1 and S2 from the nearest danger zone must be large enough that if one of the pushbuttons is released, the dangerous movement is interrupted before the operator can reach the danger zone or before the operator can reach into the danger zone (see EN 999 „The positioning of protective equipment in respect of approach speeds of parts of the human body“).
- ▶ The two-hand control device PNOZ s6.1 may **not be used on press controllers**. It is only suitable for use where the risk analysis has established a low level of risk.

#### Pilz products

Number	Designation	Order number
1	PNOZ s6.1	750 126

## Category 1, EN 954-1

### PNOZ s6.1 - Requirements in accordance with EN 574 Type IIIA

#### Safety-related characteristics in accordance with EN ISO 13849-1: 2006

- ▶ Safety function: If the output signal from a two-hand circuit shuts down in accordance with EN 574 Type IIIA, the actuator technology for shutting down a hazardous movement must shut down.
- ▶ Safety-related parts of the control system (SRP/CS): Input devices (pushbutton S1, pushbutton S2), logic (PNOZ s6), actuator (contactor KM1)
- ▶ Performance level: **PL b**
- ▶ PL information only applies under the following conditions\*:
  - Common cause failure (CCF): Requirements are considered to be met (must be tested on implementation)
  - Proof test interval: 20 years
  - Operating interval (electromechanical components): 60 operations per hour for input device and actuator
  - Pushbutton S1, S2 - characteristic data:  $B10_d$ : 20,000,000; dangerous failure rate: 20 %
  - Contactor KM1 - characteristic data:  $B10_d$ : 2,000,000; dangerous failure rate: 65 %
  - Mission time max.: Contactor KM1 must be changed after 3.8 years

\* Further requirements of EN ISO 13849-1 have also to be met (e.g. requirements for avoiding systematic faults, among others).

Минск +375447584780 [ipilz@ipilz.by](mailto:ipilz@ipilz.by) [zakaz@ipilz.by](mailto:zakaz@ipilz.by)

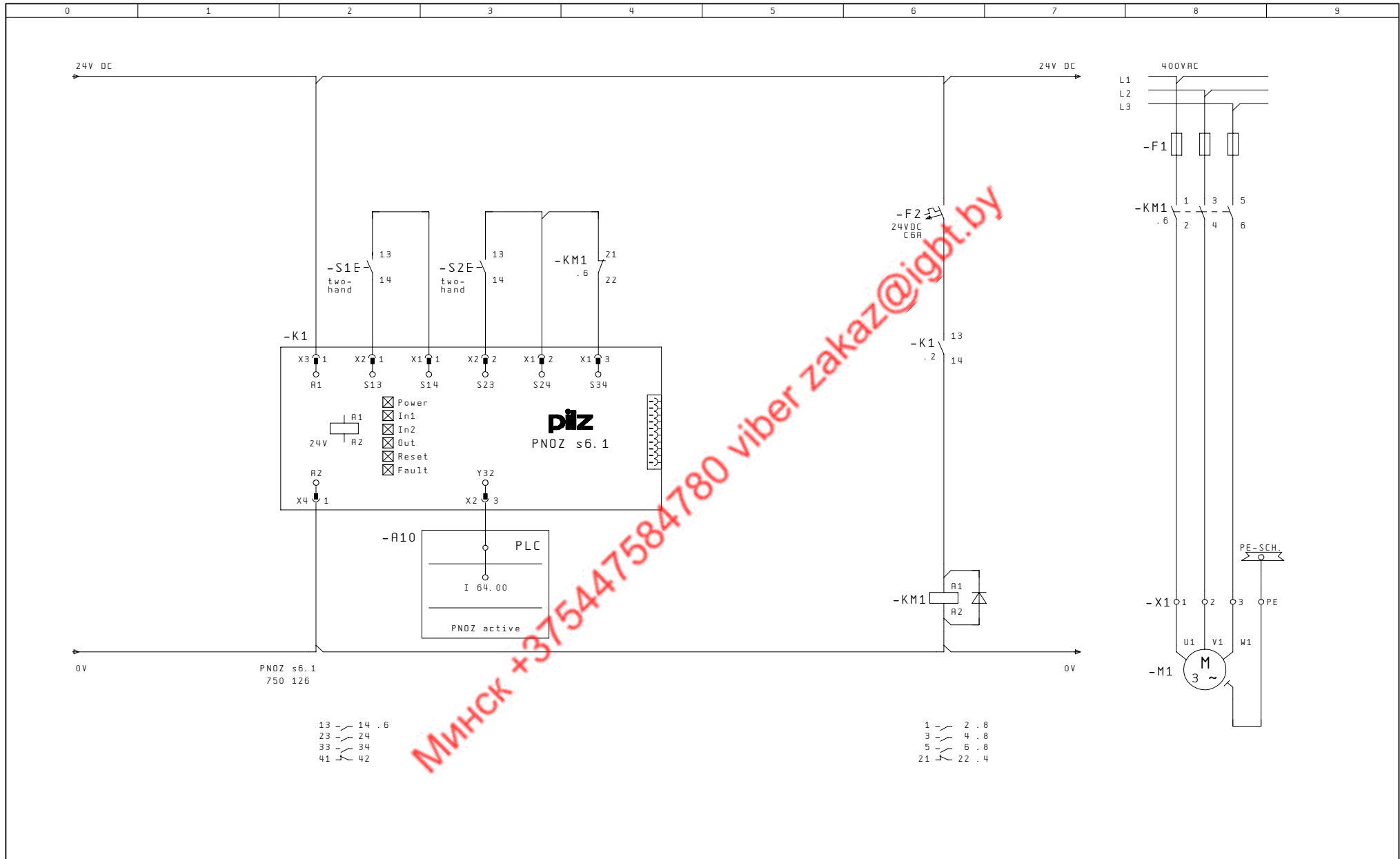

Revision	17.03.06	Date	07.12.05	Two-hand application	Pilz GmbH & Co. KG Felix-Wankel-Str. 2 73760 Ostfildern	Two-hand operation (request class 3A, EN 574)	Directory:
Name	WED	Name	WED				.. PNOZ\05PIL013
		Dep.	CS	Category 1 EN 954-1			PN0Zs6.1
							Page: 1

<b>Contents</b>	<b>Page</b>
<b>Standards And Directives</b>	
European directives and status of the standards in Europe	2.1-2
Legal regulations outside Europe and Standards for functional safety	2.1-4
Risk parameters and categories	2.1-5
Functional safety and legal status of EN/IEC 61508	2.1-6
Risk analysis	2.1-7

МИНСК +375447584780 viber zakaz@pilot.by

## European directives and status of the standards in Europe

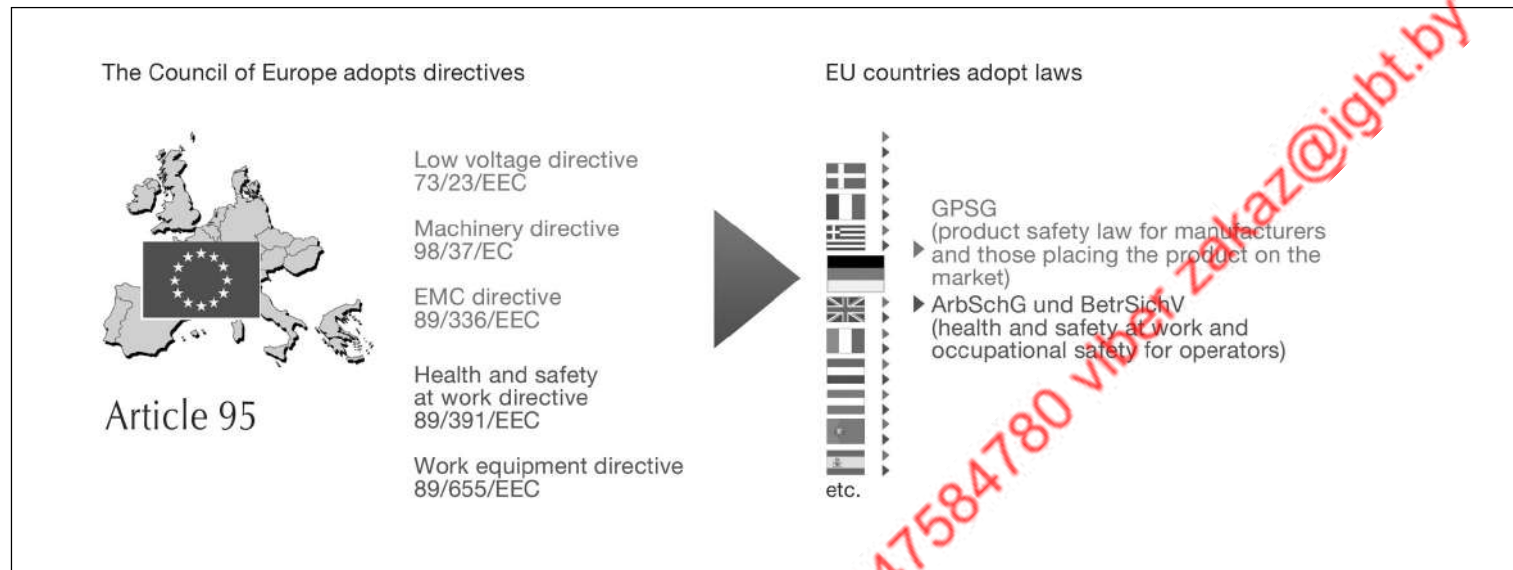

Fig. 1: Incorporation of the directives into domestic law (using Germany as an example)

### European directives

The concept of a single European internal market in terms of the “New Approach” can be traced right back to the start of the 70s: The low voltage directive was the first piece of European legislation to take into account the approach towards harmonisation of a common internal market.

Products that are covered by one or more of the following directives have to apply a CE-mark, i.e. the product must be accompanied by a declaration of conformity. With a declaration of conformity, the manufacturer confirms that his product meets all the requirements of the European directives applicable to his product. This means he can launch and sell his product within the scope of the EU without consideration of any national regulations.

- ▶ Lifts 95/16/EC
- ▶ Construction products 89/106/EEC
- ▶ Pressure equipment directive 97/23/EC
- ▶ EMC directive 89/336/EEC
- ▶ ATEX 94/9/EC
- ▶ Appliances
- ▶ burning gaseous fuels 90/396/EEC
- ▶ Machinery directive 98/37/EC
- ▶ Medical device directive 93/42/EEC
- ▶ Low voltage directive 73/23/EEC
- ▶ Personal protective equipment 89/686/EEC
- ▶ Safety of toys directive 88/378/EEC

The directives are addressed to member states, who are obliged to incorporate the European directives into domestic law. In Germany, this is normally achieved through the device safety law.

## European directives and status of the standards in Europe

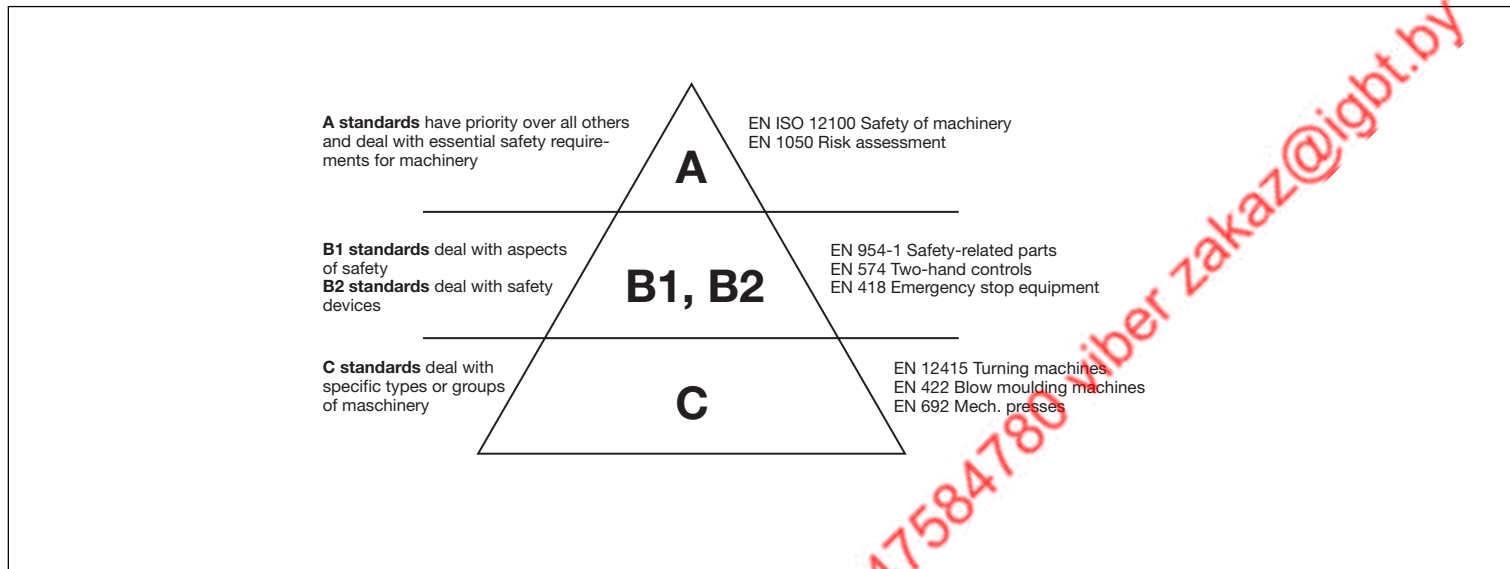

Fig. 2: Standards pyramid

### Status of the standards in Europe

The legal status of standards is continuously discussed. Inside Europe, i.e. within the scope of the European directives that are subject to the CE-marking obligation, a manufacturer is not bound by standards or other specifications. He simply needs to comply with the health and safety requirements of the directive(s). The associated benefits of a division between standards and legislation are obvious: it is easier for legislators to agree on the essential

requirements than on technical details. Also, the directives do not regularly have to be adapted to the state of technology; member states can use their own legal system for incorporation and the manufacturer is free to select how he implements the requirements of the directive.

So what are the benefits of applying the standards? With so-called harmonised standards with presumption of conformity, there is a shifting of the burden of proof, i.e. if a manufacturer applies these standards, he

can assume that he will also comply with the specific requirements of the European directives. It would therefore be up to the regulatory authorities to prove that a manufacturer did not meet the legal requirements.

However, should a manufacturer deviate from the harmonised standards, he himself must prove how he has met the essential safety requirements. This is generally done via a hazard analysis. In practice people endeavour to apply the harmonised

standards, unless the products concerned are highly innovative and no harmonised standards yet exist. The standards for which this "presumption effect" applies can be researched in the Official Journal of the EU (e.g. on the Internet). Standards in Europe are subdivided into A, B and C standards.

## Legal regulations outside Europe and Standards for functional safety

### Legal regulations outside Europe

The situation is somewhat different in the USA: primarily there are two types of standards: ANSI (American National Standards Institute) and OSHA (Occupational Safety and Health Administration). OSHA standards are published by the state and compliance is mandatory. ANSI standards, on the other hand, are developed by private organisations and generally their application is not strictly essential. However, ANSI standards are still quoted as part of a contract. And yet ANSI standards are being taken over by OSHA. You can still come across the NFPA (National Fire Protection Association), which developed NFPA 79 as a counterpart to EN 60204-1, for example. The OSHA standards can be compared with the European directives. Unlike the European directives, OSHA standards are more involved with formulating requirements for technical specifications than with abstract requirements.

The legal foundations in the USA can be seen as a mix of product standards, fire codes (NFPA), electrical codes (NEC) and national laws. Local government bodies have the authority to monitor that these codes are being enforced and implemented.

Russia and the CIS states implemented GOST-R certification some years ago. This means that technical devices falling within a specific product catalogue must undergo a

certain certification process. Machinery and any corresponding technical accessories undergo a type approval test through a European notified body, for example. This test is generally recognised by a Russian-based approvals body. From the point of view of safety, the same requirements apply as in Europe.

China, on the other hand, has introduced CCC certification. Similar to the position in Russia, technical products are subject to mandatory certification through a national approvals body in China. In addition, production sites are inspected. If a technical device falls with the scope of the product catalogue, which is subdivided into 19 categories, certification is mandatory, otherwise it will be necessary to supply a type of “declaration of no objection” from a national notified body.

Japan is currently in a transition period: the plan is for Japan to adopt the European “new approach” – in other words, to keep standards and legislation separate. At the moment the international ISO and IEC standards are being directly incorporated into national legislation, which is why people are currently confronted with frequent amendments to laws and lengthy implementation periods.

### Standards for functional safety

Different standards may be called upon to observe functional safety on control systems,

depending on the application. In the area of machine safety, EN 954-1 is the main standard for safety-related control systems. This applies to the whole chain from the sensor to the actuator, irrespective of the technology. The risk graphs and corresponding risk parameters can be used to estimate the potential risk for danger zones on machinery. The category is initially established without the use of risk-reducing measures.

## Risk parameters and categories with EN 954-1

### Risk parameters

S = Severity of injury:

- 1 = Slight (normally reversible) injury
- 2 = Serious (normally irreversible) injury, including death

F = Frequency and/or exposure to the hazard

- 1 = Seldom to quite often and/or exposure time is short
- 2 = Frequent to continuous and/or exposure time is long

P = Possibility of avoiding the hazard

- 1 = Possible under specific conditions
- 2 = Scarcely possible

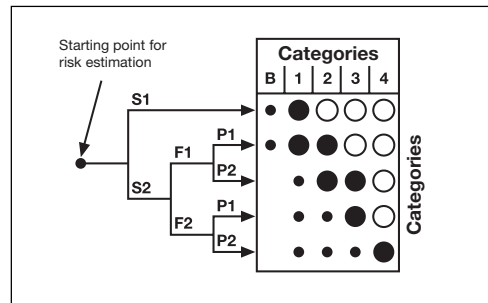

Fig. 3: Risk graph from EN 954

### Categories in accordance with EN 954-1

The control system requirements derived from the risk graph are specified as follows:

### Category B

Basic category with no special requirements = "good industrial standard"

### Category 1

Safety-related parts must be designed and constructed using well-tryed components and well-tryed safety principles.

Well-tryed means: the components have been widely used in the past with successful results in similar applications, or they have been manufactured using principles that demonstrate their suitability and reliability for safety-related applications.

Example: safety switch with forced-opening contacts.

Well-tryed safety principles are circuits constructed in such a way that certain faults can be avoided by the appropriate arrangement or layout of components.

Example: avoiding a short circuit through appropriate separation, avoiding component failures that result from over-dimensioning, using the failsafe principle (on switching off).

Note: When a fault occurs it can lead to the loss of the safety function.

### Category 2

Safety-related parts of control systems must

be designed so that their safety function(s) are checked at suitable intervals by the machine control system. The safety function(s) must be checked: at the machine start-up and prior to the initiation of any hazardous situation; periodically during operation, if the risk assessment and the kind of operation show that it is necessary.

This check may be initiated automatically or manually. Automatically, for example, the check may be initiated by a signal generated from a control system at suitable intervals. The automatic test should be provided by preference. The decision about the type of test depends on the risk assessment and the judgement of the end user or machine builder. If no fault is detected, operation may be approved as a result of the test. If a fault is detected, an output must be generated to initiate an appropriate control action. A second, independent shutdown route is required for this.

Notes: In some cases Category 2 is not applicable because the checking of the safety function cannot be applied to all components and devices. Moreover, the cost involved in implementing Category 2 correctly may be considerable, so that it may make better economic sense to implement a different category. In general Category 2 can be realised with electronic techniques. The system behaviour allows the occurrence of a fault to lead to the loss of the safety function between checks; the loss of the safety function is detected by the check.

### Category 3

Safety-related parts of control systems must be designed so that a single fault in any of these parts does not lead to the loss of the safety function.

Whenever reasonably practicable, the single fault shall be detected at or before the next demand upon the safety function. This does not mean that all faults will be detected. The accumulation of undetected faults can lead to an unintended output signal and a hazardous situation at the machine.

### Category 4

Safety-related parts of control systems must be designed so that a single fault in any of these parts does not lead to a loss of the safety function; the single fault must be detected at or before the next demand upon the safety functions (e.g. immediately at switch on, at the end of a machine operating cycle).

If this detection is not possible, then an accumulation of faults shall not lead to a loss of the safety function.

## Functional safety and legal status of EN/IEC 61508

### Functional safety with EN/IEC 61508?

EN/IEC 61508 is regarded as a generic safety standard, which deals with the functional safety of electrical, electronic and programmable electronic systems, irrespective of the application.

One of the main tasks of EN/IEC 61508 is to serve as a basis for the development of application-oriented standards. Standards' committees are currently busy in the areas of machine safety with EN/IEC 62061, and process safety with EN/IEC 61511. Also under revision is EN 954, the standard harmonised under the scope of the machinery directive, which in future will be listed as EN/ISO 13849.

These sector-specific standards are intended to continue the principle approaches of EN/IEC 61508 and to implement the requirements for the relevant application area in a suitably practical manner.

### What is the legal status of EN/IEC 61508?

As EN/IEC 61508 is not listed in the Official Journal of the European Communities for implementation as a European directive, it lacks the so-called "presumption effect". If the standard is used on its own, a control system designer cannot assume that the relevant requirements of the specific European directive have been met.

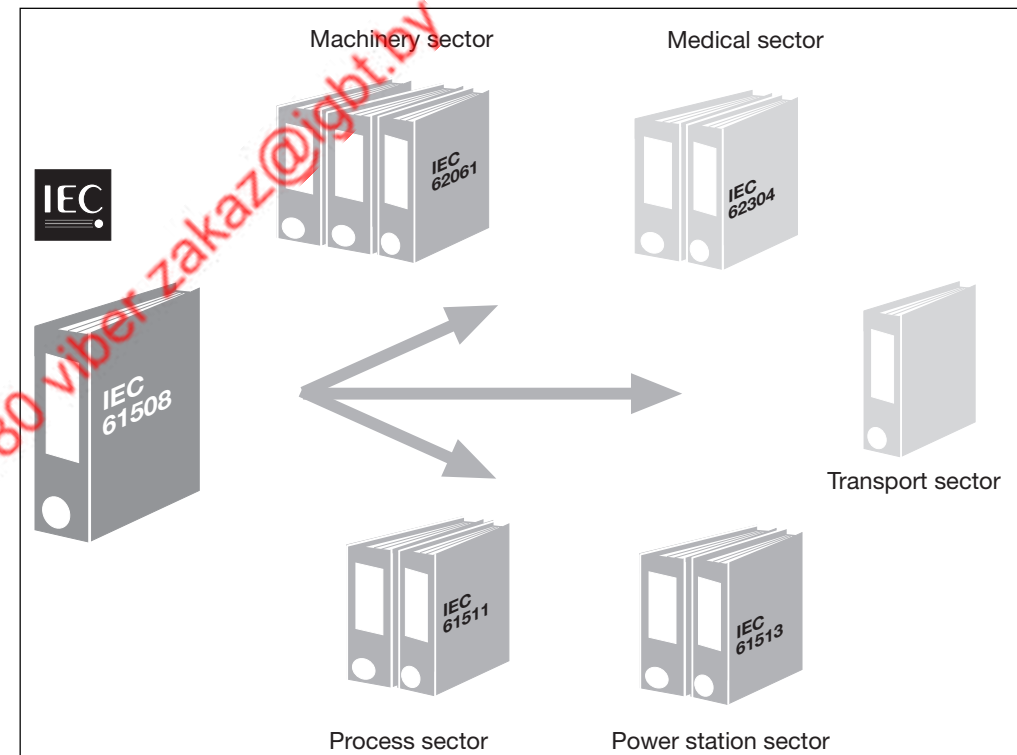

Fig. 4: Sector standards from IEC 61508

## Risk analysis

### Risk analysis

Under the terms of the machinery directive, a machine manufacturer must carry out a risk analysis in order to identify all the hazards that apply to his machine. This analysis must then be taken into account in the design and construction of the machine. This requirement also applies to operators who act as manufacturers under the terms of the machinery directive. For example, this may occur with machines that are interlinked or for machinery that has been upgraded and substantially modified.

EN 1050 contains “Principles for risk assessment” on machinery. These approaches can be called upon as part of a comprehensive analysis. EN 954-1 expands on EN 1050 with regard to the assessment of safety-related parts of control systems.

The hazards emanating from a machine may be many and varied. For example, it is necessary to consider not just mechanical hazards through crushing and shearing, but also thermal and electrical hazards and hazards from radiation. Risk reduction is therefore an iterative process, i.e. it is carried out before and during the planning phase and after completion of the plant or machine.

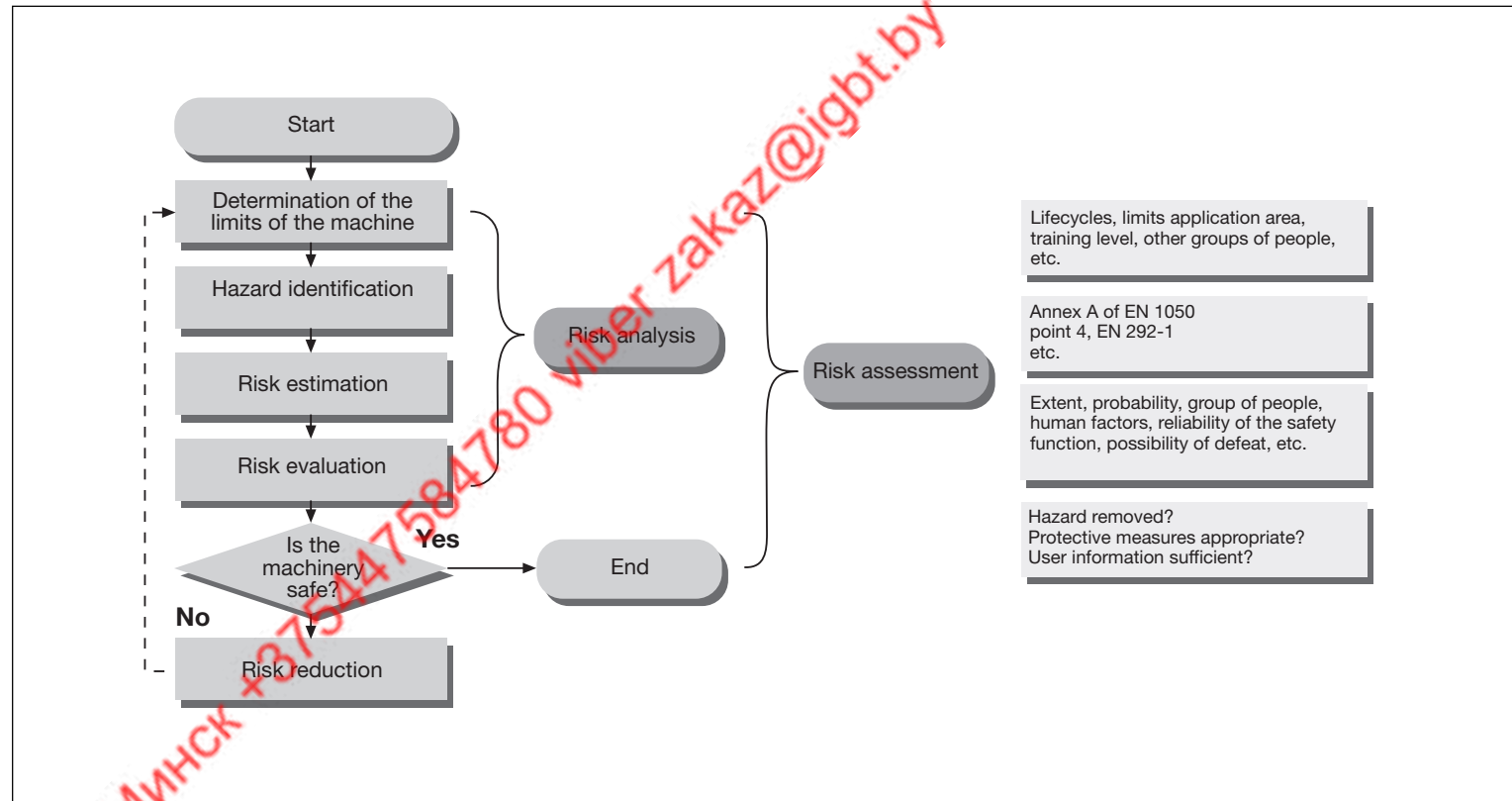

Fig. 5: Iterative process in accordance with EN 1050

МИНСК +375447584780 viber zakaz@igbt.by

<b>Contents</b>	<b>Page</b>
<b>Service</b>	
Pre-sales/after sales	
Services, concepts and solutions	3.1-2
Business terms and conditions	
Terms of delivery and payment	3.1-3

МИНСК +375447584780 viber zakaz@igbt.by

## Pre-sales/after sales Services, concepts and solutions



We are happy to advise you, in the configuration phase or during commissioning.



### Plant assessment

Analysis and assessment of the safety-related condition of your plant and machinery. Presentation of basic proposals for improvement.

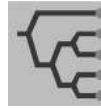

### Risk assessment

Assessment of the hazards and risks on plant and machinery, based on standards and norms.



### Safety concept

Based on the risk assessment, appropriate protective measures can be selected and a safety concept drawn up.



### Safety design

Pilz can undertake all the tasks required to implement a project: component selection, preparation of circuit diagrams, programming, control cabinet, installation, commissioning.



### CE services

Co-ordination and implementation of all the activities necessary for the "CE conformity" of plant and machinery.



### Safety sign-off

Check of all the relevant safety-related documents, creation of check lists and examination of plant and machinery.



### Technical support

Our engineers can support you in the selection, use and application of our products. They are in constant contact with customers from the widest range of industries and industrial sectors and are happy to answer your queries at any time.



**E-Mail:**  
[techsupport@pilz.de](mailto:techsupport@pilz.de)



**24-hour hotline:**  
**+49 711 3409-444**



### Training and education

A wide range of seminars and courses help to pass on the basics to minimise risks and safeguard your success.



### Worldwide representatives

Our worldwide network of subsidiaries and sales partners ensures comprehensive support and assistance with your questions and problems.



### Internet

Our homepage at [www.pilz.com](http://www.pilz.com) provides the latest information, electronic shopping, direct dialogue and enquiry functions, as well as extensive download options.



### E-Business

The focus of Pilz's E-Business activities is to strengthen customer orientation through the use of new media and to increase added value via a supplementary business model for Business-to-Business.



### Supply and repair service

From a fast, economical repair through to a long supply guarantee to safeguard your investment – always expect more from Pilz.



### Certificates and approvals

Pilz is certified to DIN ISO 9001. International approvals and certification from recognised test bodies confirm our products' suitability for worldwide use.

## Business terms and conditions

### Terms of delivery and payment



The terms of delivery and of payment of the respective Pilz company with whom a sales contract is closed are applied. As a rule this is the Pilz company that places the order. Please select the legal contract partner from the order confirmation.

МИНСК +375447584780 viber zakaz@igbt.by

МИНСК +375447584780 viber zakaz@igbt.by

**▶ AT**

Pilz Ges.m.b.H.  
Sichere Automation  
Modecenterstraße 14  
1030 Wien  
Austria  
Telephone: +43 1 7986263-0  
Telefax: +43 1 7986264  
E-Mail: pilz@pilz.at

**▶ AU**

Pilz Australia  
Safe Automation  
Suite C1, 756 Blackburn Road  
Clayton, Melbourne VIC 3168  
Australia  
Telephone: +61 3 95446300  
Telefax: +61 3 95446311  
E-Mail: safety@pilz.com.au

**▶ BE ▶ LU**

Pilz Belgium  
Safe Automation  
Bijenstraat 4  
9051 Gent (Sint-Denijs-Westrem)  
Belgium  
Telephone: +32 9 3217570  
Telefax: +32 9 3217571  
E-Mail: info@pilz.be

**▶ BR**

Pilz do Brasil  
Automação Segura  
Rua Ártico, 123 - Jd. do Mar  
09726-300  
São Bernardo do Campo - SP  
Brazil  
Telephone: +55 11 4337-1241  
Telefax: +55 11 4337-1242  
E-Mail: pilz@pilzbr.com.br

**▶ CH**

Pilz Industrieelektronik GmbH  
Gewerbepark Hintermättli  
Postfach 6  
5506 Mägenwil  
Switzerland  
Telephone: +41 62 88979-30  
Telefax: +41 62 88979-40  
E-Mail: pilz@pilz.ch

**▶ CN**

Pilz Industrial Automation  
Trading (Shanghai) Co., Ltd.  
Safe Automation  
Rm. 704-706  
No. 457 Wu Lu Mu Qi (N) Road  
Shanghai 200040  
China  
Telephone: +86 21 62494658  
Telefax: +86 21 62491300  
E-Mail: sales@pilz.com.cn

**▶ DE**

Pilz GmbH & Co. KG  
Sichere Automation  
Felix-Wankel-Straße 2  
73760 Ostfildern  
Germany  
Telephone: +49 711 3409-0  
Telefax: +49 711 3409-133  
E-Mail: pilz.gmbh@pilz.de

**▶ DK**

Pilz Skandinavien K/S  
Safe Automation  
Ellegaardvej 25 L  
6400 Sønderborg  
Denmark  
Telephone: +45 74436332  
Telefax: +45 74436342  
E-Mail: pilz@pilz.dk

**▶ ES**

Pilz Industrieelektronik S.L.  
Safe Automation  
Camí Ral, 130  
Poligono Industrial Palou Nord  
08400 Granollers  
Spain  
Telephone: +34 938497433  
Telefax: +34 938497544  
E-Mail: pilz@pilz.es

**▶ FI**

Pilz Skandinavien K/S  
Safe Automation  
Nuujamiestentie 5 A  
00400 Helsinki  
Finland  
Telephone: +358 9 27093700  
Telefax: +358 9 27093709  
E-Mail: pilz.fi@pilz.dk

**▶ FR**

Pilz France Electronic  
1, rue Jacob Mayer  
BP 12  
67037 Strasbourg Cedex 2  
France  
Telephone: +33 3 88104000  
Telefax: +33 3 88108000  
E-Mail: siege@pilz-france.fr

**▶ GB**

Pilz Automation Technology  
Safe Automation  
Willow House, Medlicott Close  
Oakley Hay Business Park  
Corby  
Northants NN18 9NF  
United Kingdom  
Telephone: +44 1536 460766  
Telefax: +44 1536 460866  
E-Mail: sales@pilz.co.uk

**▶ IE**

Pilz Ireland Industrial Automation  
Cork Business and Technology Park  
Model Farm Road  
Cork  
Ireland  
Telephone: +353 21 4346535  
Telefax: +353 21 4804994  
E-Mail: sales@pilz.ie

**▶ IT**

Pilz Italia Srl  
Automazione sicura  
Via Meda 2/A  
22060 Novedrate (CO)  
Italy  
Telephone: +39 031 789511  
Telefax: +39 031 789555  
E-Mail: info@pilz.it

**▶ JP**

Pilz Japan Co., Ltd.  
Safe Automation  
Shin-Yokohama Fujika Building 5F  
2-5-9 Shin-Yokohama  
Kohoku-ku  
Yokohama 222-0033  
Japan  
Telephone: +81 45 471-2281  
Telefax: +81 45 471-2283  
E-Mail: pilz@pilz.co.jp

**▶ KR**

Pilz Korea Ltd.  
Safe Automation  
9F Jo-Yang Bld. 50-10  
Chungmuro2-Ga Jung-Gu  
100-861 Seoul  
Republic of Korea  
Telephone: +82 2 2263 9541  
Telefax: +82 2 2263 9542  
E-Mail: info@pilzkorea.co.kr

**▶ www**

www.pilz.com

**▶ Technical support**

+49 711 3409-444

**▶ MX**

Pilz de Mexico, S. de R.L. de C.V.  
Automatización Segura  
Circuito Pintores # 170  
Cd. Satelite  
C.P. 53100  
Naucalpan de Juarez, Edo. de Mexico  
Mexico  
Telephone: +52 55 5572 1300  
Telefax: +52 55 5572 4194  
E-Mail: info@mx.pilz.com

**▶ NL**

Pilz Nederland  
Veilige automatisering  
Postbus 186  
4130 ED Vianen  
Netherlands  
Telephone: +31 347 320477  
Telefax: +31 347 320485  
E-Mail: info@pilz.nl

**▶ NZ**

Pilz New Zealand  
Safe Automation  
5 Nixon Road  
Mangere  
Auckland  
New Zealand  
Telephone: +64 9 6345350  
Telefax: +64 9 6345352  
E-Mail: t.catterson@pilz.co.nz

**▶ PT**

Pilz Industrieelektronik S.L.  
R. Eng Duarte Pacheco, 120  
4 Andar Sala 21  
4470-174 Maia  
Portugal  
Telephone: +351 229407594  
Telefax: +351 229407595  
E-Mail: pilz@pilz.es

**▶ SE**

Pilz Skandinavien K/S  
Safe Automation  
Energigatan 10 B  
43437 Kungsbacka  
Sweden  
Telephone: +46 300 13990  
Telefax: +46 300 30740  
E-Mail: pilz.se@pilz.dk

**▶ TR**

Pilz Emniyet Otomasyon  
Ürünleri ve Hizmetleri Tic. Ltd. Şti.  
İsmail Paşa Sokak No: 8  
Koşuyolu/Kadıköy  
34718 İstanbul  
Turkey  
Telephone: +90 216 5452910  
Telefax: +90 216 5452913  
E-Mail: pilz.tr@pilz.de

**▶ US ▶ CA**

Pilz Automation Safety L.P.  
7150 Commerce Boulevard  
Canton  
Michigan 48187  
USA  
Telephone: +1 734 354-0272  
Telefax: +1 734 354-3355  
E-Mail: info@pilzusa.com

**▶ ...**

In many countries we are represented by sales partners.

Please refer to our Homepage for further details or contact our headquarters.2

**pilz**  
more than automation  
safe automation

Pilz GmbH & Co. KG  
Sichere Automation  
Felix-Wankel-Straße 2  
73760 Ostfildern, Germany  
Telephone: +49 711 3409-0  
Telefax: +49 711 3409-133  
E-Mail: pilz.gmbh@pilz.de



МИНСК +375447584780 viber zakaz@igbt.by

**PNOZ s4.1**

Safety relays

**pilz**

Минск +375447584780 viber zakaz@igbt.by

This document is the original document.

All rights to this documentation are reserved by Pilz GmbH & Co. KG. Copies may be made for internal purposes. Suggestions and comments for improving this documentation will be gratefully received.

Pilz®, PIT®, PMI®, PNOZ®, Primo®, PSEN®, PSS®, PVIS®, SafetyBUS p®, SafetyEYE®, SafetyNET p®, the spirit of safety® are registered and protected trademarks of Pilz GmbH & Co. KG in some countries.



SD means Secure Digital

## Safety relay PNOZ s4.1

The safety relay provides a safety-related interruption of a safety circuit.

The safety relay meets the requirements of EN 60947-5-1, EN 60204-1 and VDE 0113-1 and may be used in applications with

- ▶ E-STOP pushbuttons
- ▶ Safety gates
- ▶ Light beam devices

It is suitable for use in furnaces in accordance with EN 50156-1.

## For your safety

- ▶ Only install and commission the unit if you have read and understood these operating instructions and are familiar with the applicable regulations for health and safety at work and accident prevention.  
Ensure VDE and local regulations are met, especially those relating to safety.
- ▶ Any guarantee is rendered invalid if the housing is opened or unauthorised modifications are carried out.

## Unit features

- ▶ Positive-guided relay outputs:
  - 3 safety contacts (N/O), instantaneous
  - 1 auxiliary contact (N/C), instantaneous
- ▶ 1 semiconductor output
- ▶ Connection options for:
  - E-STOP pushbuttons
  - Safety gate limit switches
  - Reset buttons
  - Light beam devices
  - PSEN
  - Safety valves for furnaces
- ▶ A connector can be used to connect 1 PNOZsigma contact expansion module
- ▶ Operating modes can be set via rotary switch
- ▶ LED indicator for:
  - Supply voltage
  - Input status, channel 1
  - Input status, channel 2
  - Switch status of the safety contacts
  - Start circuit
  - Errors
- ▶ Plug-in connection terminals (either spring-loaded terminal or screw terminal)

## Safety features

The relay meets the following safety requirements:

- ▶ The circuit is redundant with built-in self-monitoring.
- ▶ The safety function remains effective in the case of a component failure.
- ▶ The correct opening and closing of the safety function relays is tested automatically in each on-off cycle.
- ▶ The unit has an electronic fuse.

## Block diagram/terminal configuration

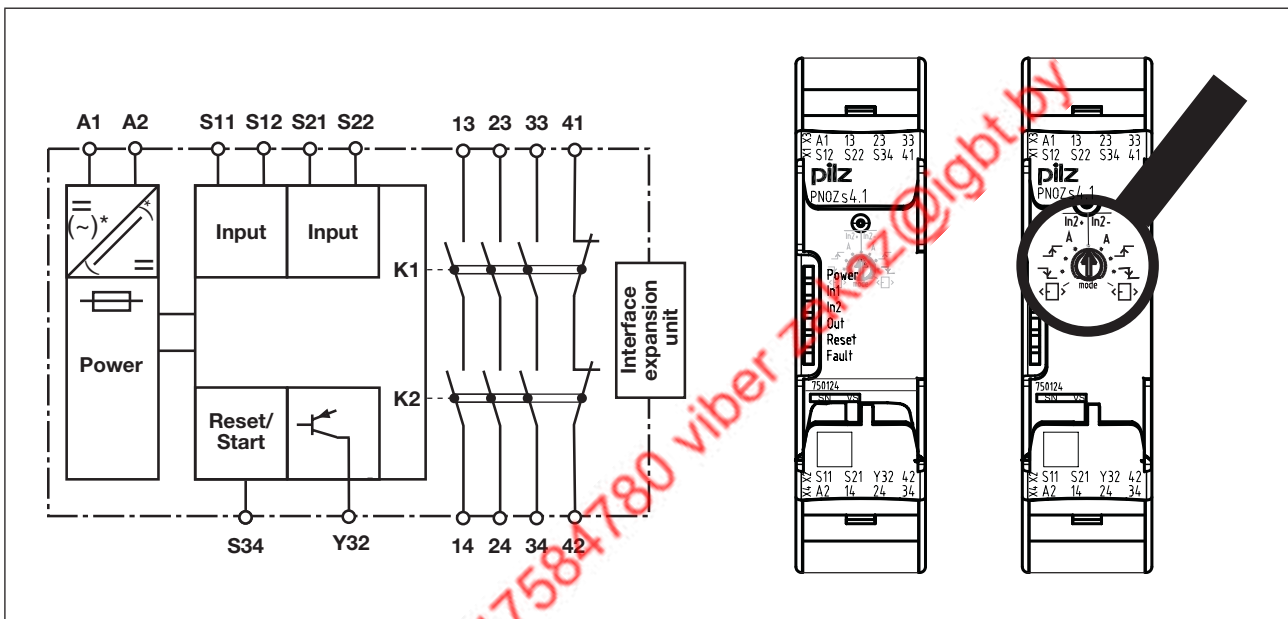



Centre: Front view with cover, right: Front view without cover

\*only when  $U_B = 48 - 240$  V AC/DC

## Function description

- ▶  $\overline{\text{In}2\text{+}}$  Single-channel operation: no redundancy in the input circuit, earth faults in the start circuit and input circuit are detected.
- ▶ Dual-channel operation without detection of shorts across contacts: redundant input circuit, detects
  - earth faults in the start and input circuit,
  - short circuits in the input circuit and, with a monitored start, in the start circuit too.
- ▶  $\overline{\text{In}2\text{-}}$  Dual-channel operation with detection of shorts across contacts: redundant input circuit, detects
  - earth faults in the start and input circuit,
  - short circuits in the input circuit and, with a monitored start, in the start circuit too,
  - shorts between contacts in the input circuit.
- ▶ **A** Automatic start: Unit is active once the input circuit has been closed.

- ▶ Manual start: Unit is active once the input circuit is closed and then the start circuit is closed.
- ▶  Monitored start with falling edge: Unit is active once
  - the input circuit is closed and then the start circuit is closed and opened again.
  - the start circuit is closed and then opened again once the input circuit is closed.
- ▶  Monitored start with rising edge: Unit is active once the input circuit is closed and once the start circuit is closed after the waiting period has elapsed (see technical details).
- ▶  Start with start-up test: The unit checks whether safety gates that are closed are opened and then closed again when supply voltage is applied.
- ▶ Increase in the number of available instantaneous safety contacts by connecting contact expander modules or external contactors/relays; A connector can be used to connect 1 PNOZsigma contact expander module.

## Installation

### Install base unit without contact expansion module:

- ▶ Ensure that the plug terminator is inserted at the side of the unit.

### Connect base unit and PNOZsigma contact expansion module:

- ▶ Remove the plug terminator at the side of the base unit and at the contact expansion module.
- ▶ Connect the base unit and the contact expansion module to the supplied connector before mounting the units to the DIN rail.

### Installation in control cabinet

- ▶ The safety relay should be installed in a control cabinet with a protection type of at least IP54.
- ▶ Use the notch on the rear of the unit to attach it to a DIN rail (35 mm).
- ▶ When installed vertically: Secure the unit by using a fixing element (e.g. retaining bracket or end angle).
- ▶ Push the device upwards or downwards before lifting it from the DIN rail.

## Wiring

Please note:

- ▶ Information given in the "Technical details" must be followed.
- ▶ Outputs 13-14, 23-24, 33-34 are safety contacts; output 41-42 is an auxiliary contact (e.g. for display).
- ▶ Auxiliary contact 41-42 and semiconductor output Y32 should **not** be used for safety circuits!
- ▶ To prevent contact welding, a fuse should be connected before the output contacts (see technical details).

- ▶ Calculation of the max. cable length  $l_{max}$  in the input circuit:

$$l_{max} = \frac{R_{lmax}}{R_l / km}$$

$R_{lmax}$  = max. overall cable resistance (see technical details)

$R_l / km$  = cable resistance/km

- ▶ Use copper wire that can withstand 60/75 °C.
- ▶ Sufficient fuse protection must be provided on all output contacts with capacitive and inductive loads.
- ▶ With  $U_B$  48 – 240 VAC/DC: Connect S21 to the protective earth system

## Preparing for operation

### Operating modes

The operating mode is set via the rotary switch on the unit. You can do this by opening the cover on the front of the unit.



#### CAUTION!

Do not adjust the rotary switch during operation, otherwise an error message will appear, the safety contacts will open and the unit will not be ready for operation until the supply voltage has been switched off and then on again.

### Set operating modes

- ▶ Switch off supply voltage.
- ▶ Select operating mode via the operating mode selector switch "mode".
- ▶ If the operating mode selector switch "mode" is in its start position (vertical position), an error message will appear.

Operating mode selector switch "mode"	Automatic/manual start	Monitored start rising edge	Monitored start falling edge	Automatic start with start-up test
Without detection of shorts across contacts				
With detection of shorts across contacts				

**Connection**

▶ Supply voltage

Supply voltage	AC	DC

▶ Input circuit

Input circuit	Single-channel	Dual-channel
E-STOP <b>without</b> detection of shorts across contacts		
E-STOP <b>with</b> detection of shorts across contacts		
Safety gate <b>without</b> detection of shorts across contacts		
Safety gate with detection of shorts across contacts		
Light beam device or safety switch with detection of shorts across contacts via ESPE (only when UB = 24 VDC)		

Минск +375 44 758 4780 viber zakaz@igbt.by

▶ Reset circuit/feedback loop

Reset circuit/feedback loop	Reset circuit	Feedback loop
Automatic reset		
Manual/monitored reset		

▶ Semiconductor output

U <sub>B</sub> 24 VDC	U <sub>B</sub> 48 - 240 VAC/DC
*Connect together the 0V connections on all the external power supplies	



**Information**

If a base unit and a contact expansion module from the PNOZsigma range are connected via the connector, no additional wiring is necessary.



**Legend**

- ▶ S1/S2: E-STOP/safety gate switch
- ▶ S3: Reset button
- ▶ ↑: Switch operated
- ▶ : Gate open
- ▶ : Gate closed

## Operation

The unit is ready for operation when the Power LED is permanently lit.

LEDs indicate the status and errors during operation:





-  LED on
-  LED flashes





### Information











Status indicators and error indicators may occur independently. In the case of an error display, the "Fault" LED will light or flash (exception: "Supply voltage too low"). An LED that is also flashing indicates the potential cause of the error. An LED that is lit and is static indicates a normal operating status. Several status indicators and error indicators may occur simultaneously.

### Status indicators

-  **Power**  
Supply voltage is present.
-  **In1**  
Input circuit at S12 is closed.
-  **In2**  
Input circuit at S22 is closed.
-  **Out**  
Safety contacts are closed and semiconductor output Y32 carries a high signal.
-  **Reset**  
24 V DC is present at S34.

### Error indicators

-  **All LEDs off**  
Diagnostics: Short across contacts/earth fault; unit switched off
  - ▶ Remedy: Rectify short across contacts/earth fault, switch off supply voltage for 1 min.
-  **Fault**  
Diagnostics: Plug terminator not connected
  - ▶ Remedy: Insert plug terminator, switch supply voltage off and then on again.

-  **Fault**  
Diagnostics: Internal error, unit defective
- ▶ Remedy: Switch supply voltage off and then on again, change unit if necessary.
-  **Power**  
Diagnostics: Supply voltage too low
- ▶ Remedy: Check the supply voltage.
-  **In1, In2 alternately**
-  **Fault**  
Diagnostics: Short detected between S12 and S22
- ▶ Remedy: Rectify short across contacts, switch supply voltage off and then on again.
-  **In1**
-  **Fault**  
Diagnostics: Power-up blocked due to short-term interruption at S12; input circuits not operated simultaneously
- ▶ Remedy: Open both input circuits, S12 and S22, simultaneously and then close again.
-  **In2**
-  **Fault**  
Diagnostics: Power-up blocked due to short-term interruption at S22; input circuits not operated simultaneously
- ▶ Remedy: Open both input circuits, S12 and S22, simultaneously and then close again.
-  **Reset**
-  **Fault**  
Diagnostics: Position of rotary switch is not permitted or rotary switch was adjusted during operation.
- ▶ Remedy: Switch supply voltage off and then on again.



### Power, In1, In2, Out, Reset, Fault

Diagnostics: The operating mode selector switch "mode" is in its start position (vertical position)

- ▶ Remedy: Switch off the supply voltage and set the required operating mode on operating mode selector switch "mode".

## Faults - malfunctions

- ▶ Contact malfunctions: If the contacts have welded, reactivation will not be possible after the input circuit has opened.

## Service life graph

The service life graphs indicate the number of cycles from which failures due to wear must be expected. The wear is mainly caused by the electrical load; the mechanical load is negligible.

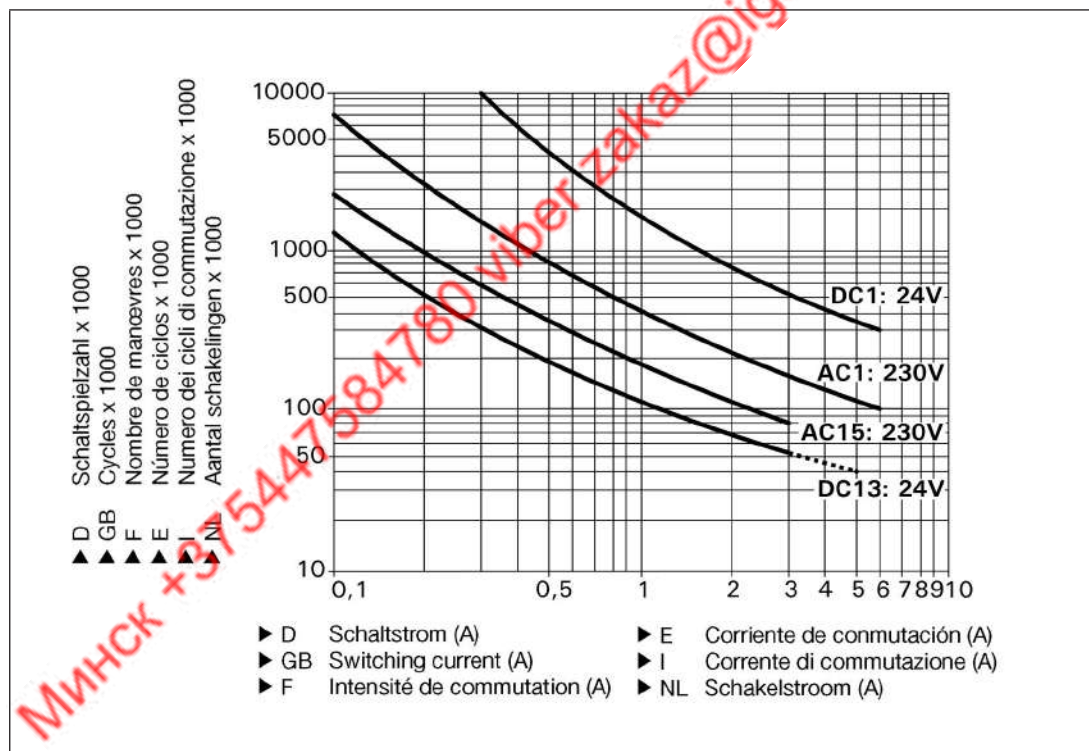

### Example

- ▶ Inductive load: 0,2 A
- ▶ Utilisation category: AC15
- ▶ Contact service life: 1,000,000 cycles

Provided the application requires fewer than 1,000,000 cycles, the PFH value (see technical details) can be used in the calculation.

To increase the service life, sufficient spark suppression must be provided on all output contacts. With capacitive loads, any power surges that occur must be noted. With contactors, use freewheel diodes for spark suppression.

## Technical details

General	750124	750154	751124	751154
Approvals	CCC, CE, GOST, TÜV, cULus Listed	CCC, CE, GOST, TÜV, cULus Listed	CCC, CE, GOST, TÜV, cULus Listed	CCC, CE, GOST, TÜV, cULus Listed
Electrical data	750124	750154	751124	751154
Supply voltage				
Voltage	24 V	48 - 240 V	24 V	48 - 240 V
Type	DC	AC/DC	DC	AC/DC
Voltage tolerance	-15 %/+10 %	-15 %/+10 %	-15 %/+10 %	-15 %/+10 %
Output of external power supply (AC)	–	5,0 VA	–	5,0 VA
Output of external power supply (DC)	2,5 W	2,5 W	2,5 W	2,5 W
Frequency range AC	–	50 - 60 Hz	–	50 - 60 Hz
Residual ripple DC	20 %	160 %	20 %	160 %
Continuous duty	100 %	100 %	100 %	100 %
Max. inrush current impulse				
Reset circuit	0,20 A	0,20 A	0,20 A	0,20 A
Feedback loop	0,20 A	0,20 A	0,20 A	0,20 A
Max. overall cable resistance R <sub>lmax</sub>				
Single-channel at UB DC	30 Ohm	30 Ohm	30 Ohm	30 Ohm
Single-channel at UB AC	–	30 Ohm	–	30 Ohm
Dual-channel without detection of shorts across contacts at UB DC	60 Ohm	60 Ohm	60 Ohm	60 Ohm
Dual-channel without detection of shorts across contacts at UB AC	–	60 Ohm	–	60 Ohm
Dual-channel with detection of shorts across contacts at UB DC	30 Ohm	30 Ohm	30 Ohm	30 Ohm
Dual-channel with detection of shorts across contacts at UB AC	–	30 Ohm	–	30 Ohm

<b>Electrical data</b>	<b>750124</b>	<b>750154</b>	<b>751124</b>	<b>751154</b>
Voltage at				
Input circuit DC	24,0 V	24,0 V	24,0 V	24,0 V
Reset circuit DC	24,0 V	24,0 V	24,0 V	24,0 V
Feedback loop DC	24,0 V	24,0 V	24,0 V	24,0 V
Current at				
Input circuit DC	50,0 mA	50,0 mA	50,0 mA	50,0 mA
Reset circuit DC	50,0 mA	50,0 mA	50,0 mA	50,0 mA
Feedback loop	50,0 mA	50,0 mA	50,0 mA	50,0 mA
Number of output contacts				
Instantaneous safety contacts (N/O)	3	3	3	3
Auxiliary contacts (N/C)	1	1	1	1
<b>Inputs</b>				
Number	2	2	2	2
<b>Semiconductor outputs</b>				
Number	1	1	1	1
Voltage	24,0 V	24,0 V	24,0 V	24,0 V
Current	20 mA	20 mA	20 mA	20 mA
<b>Relay outputs</b>				
Max. short circuit current I <sub>K</sub>	1 kA	1 kA	1 kA	1 kA
Utilisation category				
In accordance with the standard	EN 60947-4-1	EN 60947-4-1	EN 60947-4-1	EN 60947-4-1
Auxiliary contacts, AC1 at	240 V	240 V	240 V	240 V
Min. current	0,01 A	0,01 A	0,01 A	0,01 A
Max. current	1,5 A	1,5 A	1,5 A	1,5 A
Max. power	375 VA	375 VA	375 VA	375 VA
Auxiliary contacts, DC1 at	24 V	24 V	24 V	24 V
Min. current	0,01 A	0,01 A	0,01 A	0,01 A
Max. current	6,0 A	6,0 A	6,0 A	6,0 A
Max. power	150 W	150 W	150 W	150 W
Safety contacts, AC1 at	240 V	240 V	240 V	240 V
Max. current	1,5 A	1,5 A	1,5 A	1,5 A
Min. current	0,01 A	0,01 A	0,01 A	0,01 A
Max. power	375 VA	375 VA	375 VA	375 VA
Safety contacts, DC1 at	24 V	24 V	24 V	24 V
Max. current	6,0 A	6,0 A	6,0 A	6,0 A
Min. current	0,01 A	0,01 A	0,01 A	0,01 A
Max. power	150 W	150 W	150 W	150 W

Relay outputs	750124	750154	751124	751154
Utilisation category				
In accordance with the standard	EN 60947-5-1	EN 60947-5-1	EN 60947-5-1	EN 60947-5-1
Auxiliary contacts, AC15 at	230 V	230 V	230 V	230 V
Max. current	0,6 A	0,6 A	0,6 A	0,6 A
Auxiliary contacts, DC13 (6 cycles/min) at	24 V	24 V	24 V	24 V
Max. current	0,4 A	0,4 A	0,4 A	0,4 A
Safety contacts, AC15 at	230 V	230 V	230 V	230 V
Max. current	0,6 A	0,6 A	0,6 A	0,6 A
Safety contacts, DC13 (6 cycles/min) at	24 V	24 V	24 V	24 V
Max. current	0,4 A	0,4 A	0,4 A	0,4 A
Contact fuse protection, external safety contacts				
In accordance with the standard	EN 60947-5-1	EN 60947-5-1	EN 60947-5-1	EN 60947-5-1
Blow-out fuse, quick	6 A	6 A	6 A	6 A
Blow-out fuse, slow	4 A	4 A	4 A	4 A
Circuit breaker, 24V AC/DC, characteristic B/C	4 A	4 A	4 A	4 A
Contact fuse protection, external auxiliary contacts				
Blow-out fuse, quick	6 A	6 A	6 A	6 A
Blow-out fuse, slow	4 A	4 A	4 A	4 A
Circuit breaker, 24 V AC/DC, characteristic B/C	4 A	4 A	4 A	4 A
Contact material	AgCuNi + 0,2 µm Au	AgCuNi + 0,2 µm Au	AgCuNi + 0,2 µm Au	AgCuNi + 0,2 µm Au

<b>Conventional thermal current while loading several contacts</b>	<b>750124</b>	<b>750154</b>	<b>751124</b>	<b>751154</b>
Ith per contact at UB				
AC				
Conv. therm. current with 1 contact	–	<b>6,00 A</b>	–	<b>6,00 A</b>
Conv. therm. current with 2 contacts	–	<b>6,00 A</b>	–	<b>6,00 A</b>
Conv. therm. current with 3 contacts	–	<b>4,50 A</b>	–	<b>4,50 A</b>
Ith per contact at UB				
DC				
Conv. therm. current with 1 contact	<b>6,00 A</b>	<b>6,00 A</b>	<b>6,00 A</b>	<b>6,00 A</b>
Conv. therm. current with 2 contacts	<b>6,00 A</b>	<b>6,00 A</b>	<b>6,00 A</b>	<b>6,00 A</b>
Conv. therm. current with 3 contacts	<b>4,50 A</b>	<b>4,50 A</b>	<b>4,50 A</b>	<b>4,50 A</b>
<b>Times</b>	<b>750124</b>	<b>750154</b>	<b>751124</b>	<b>751154</b>
Switch-on delay				
With automatic reset typ.	<b>170 ms</b>	<b>170 ms</b>	<b>170 ms</b>	<b>170 ms</b>
With automatic reset max.	<b>300 ms</b>	<b>300 ms</b>	<b>300 ms</b>	<b>300 ms</b>
With automatic reset after power on typ.	<b>350 ms</b>	<b>350 ms</b>	<b>350 ms</b>	<b>350 ms</b>
With automatic reset after power on max.	<b>600 ms</b>	<b>600 ms</b>	<b>600 ms</b>	<b>600 ms</b>
With manual reset typ.	<b>40 ms</b>	<b>40 ms</b>	<b>40 ms</b>	<b>40 ms</b>
With manual reset max.	<b>300 ms</b>	<b>300 ms</b>	<b>300 ms</b>	<b>300 ms</b>
With monitored reset with rising edge typ.	<b>35 ms</b>	<b>35 ms</b>	<b>35 ms</b>	<b>35 ms</b>
With monitored reset with rising edge max.	<b>50 ms</b>	<b>50 ms</b>	<b>50 ms</b>	<b>50 ms</b>
With monitored reset with falling edge typ.	<b>55 ms</b>	<b>55 ms</b>	<b>55 ms</b>	<b>55 ms</b>
With monitored reset with falling edge max.	<b>70 ms</b>	<b>70 ms</b>	<b>70 ms</b>	<b>70 ms</b>

Times	750124	750154	751124	751154
Delay-on de-energisation				
With E-STOP typ.	10 ms	10 ms	10 ms	10 ms
With E-STOP max.	20 ms	20 ms	20 ms	20 ms
With power failure typ.	40 ms	40 ms	40 ms	40 ms
With power failure max.	80 ms	80 ms	80 ms	80 ms
Recovery time at max. switching frequency 1/s				
After E-STOP	50 ms	50 ms	50 ms	50 ms
After power failure	100 ms	100 ms	100 ms	100 ms
Waiting period with a monitored reset				
With rising edge	120 ms	120 ms	120 ms	120 ms
With falling edge	250 ms	150 ms	250 ms	150 ms
Min. start pulse duration with a monitored reset				
With rising edge	30 ms	30 ms	30 ms	30 ms
With falling edge	100 ms	100 ms	100 ms	100 ms
Supply interruption before de-energisation	20 ms	20 ms	20 ms	20 ms
Simultaneity, channel 1 and 2	∞	∞	∞	∞
<b>Environmental data</b>	<b>750124</b>	<b>750154</b>	<b>751124</b>	<b>751154</b>
Climatic suitability	EN 60068-2-78	EN 60068-2-78	EN 60068-2-78	EN 60068-2-78
Ambient temperature				
Temperature range	-10 - 60 °C	-10 - 60 °C	-10 - 60 °C	-10 - 60 °C
Storage temperature				
Temperature range	-40 - 85 °C	-40 - 85 °C	-40 - 85 °C	-40 - 85 °C
EMC	EN 60947-5-1, EN 61000-6-2, EN 61000-6-4	EN 60947-5-1, EN 61000-6-2, EN 61000-6-4	EN 60947-5-1, EN 61000-6-2, EN 61000-6-4	EN 60947-5-1, EN 61000-6-2, EN 61000-6-4
Vibration				
In accordance with the standard	EN 60068-2-6	EN 60068-2-6	EN 60068-2-6	EN 60068-2-6
Frequency	10,0 - 150,0 Hz	10,0 - 150,0 Hz	10,0 - 150,0 Hz	10,0 - 150,0 Hz
Max. amplitude	0,35 mm	0,35 mm	0,35 mm	0,35 mm

<b>Environmental data</b>	<b>750124</b>	<b>750154</b>	<b>751124</b>	<b>751154</b>
Airgap creepage				
In accordance with the standard	<b>EN 60947-1</b>	<b>EN 60947-1</b>	<b>EN 60947-1</b>	<b>EN 60947-1</b>
Overvoltage category	<b>III</b>	<b>III</b>	<b>III</b>	<b>III</b>
Pollution degree	<b>2</b>	<b>2</b>	<b>2</b>	<b>2</b>
Rated insulation voltage	<b>250 V</b>	<b>250 V</b>	<b>250 V</b>	<b>250 V</b>
Rated impulse withstand voltage	<b>4,00 kV</b>	<b>4,00 kV</b>	<b>4,00 kV</b>	<b>4,00 kV</b>
Protection type				
Mounting (e.g. cabinet)	<b>IP54</b>	<b>IP54</b>	<b>IP54</b>	<b>IP54</b>
Housing	<b>IP40</b>	<b>IP40</b>	<b>IP40</b>	<b>IP40</b>
Terminals	<b>IP20</b>	<b>IP20</b>	<b>IP20</b>	<b>IP20</b>
<b>Mechanical data</b>	<b>750124</b>	<b>750154</b>	<b>751124</b>	<b>751154</b>
Mounting position	<b>Any</b>	<b>Any</b>	<b>Any</b>	<b>Any</b>
Mechanical life	<b>10,000,000 cycles</b>	<b>10,000,000 cycles</b>	<b>10,000,000 cycles</b>	<b>10,000,000 cycles</b>
Material				
Bottom	<b>PC</b>	<b>PC</b>	<b>PC</b>	<b>PC</b>
Front	<b>PC</b>	<b>PC</b>	<b>PC</b>	<b>PC</b>
Top	<b>PC</b>	<b>PC</b>	<b>PC</b>	<b>PC</b>
Cross section of external conductors with screw terminals				
1 core flexible	<b>0,25 - 2,50 mm<sup>2</sup>, 24 - 12 AWG</b>	<b>0,25 - 2,50 mm<sup>2</sup>, 24 - 12 AWG</b>	–	–
2 core with the same cross section, flexible with crimp connectors, no plastic sleeve	<b>0,25 - 1,00 mm<sup>2</sup>, 24 - 16 AWG</b>	<b>0,25 - 1,00 mm<sup>2</sup>, 24 - 16 AWG</b>	–	–
2 core with the same cross section, flexible without crimp connectors or with TWIN crimp connectors	<b>0,20 - 1,50 mm<sup>2</sup>, 24 - 16 AWG</b>	<b>0,20 - 1,50 mm<sup>2</sup>, 24 - 16 AWG</b>	–	–
Torque setting with screw terminals	<b>0,50 Nm</b>	<b>0,50 Nm</b>	–	–
Connection type	<b>Screw terminal</b>	<b>Screw terminal</b>	<b>Spring-loaded terminal</b>	<b>Spring-loaded terminal</b>
Mounting type	<b>plug in</b>	<b>plug in</b>	<b>plug in</b>	<b>plug in</b>
Cross section of external conductors with spring-loaded terminals: flexible with/without crimp connector	–	–	<b>0,20 - 2,50 mm<sup>2</sup>, 24 - 12 AWG</b>	<b>0,20 - 2,50 mm<sup>2</sup>, 24 - 12 AWG</b>

Mechanical data	750124	750154	751124	751154
Spring-loaded terminals: Terminal points per connection	–	–	2	2
Stripping length	–	–	9 mm	9 mm
Dimensions				
Height	98,0 mm	98,0 mm	100,0 mm	100,0 mm
Width	22,5 mm	22,5 mm	22,5 mm	22,5 mm
Depth	120,0 mm	120,0 mm	120,0 mm	120,0 mm
Weight	190 g	210 g	190 g	210 g

The standards current on 2009-12 apply.

#### Safety characteristic data

Operating mode	EN ISO 13849-1: 2006 PL	EN ISO 13849-1: 2006 Category	EN IEC 62061 SIL CL	EN IEC 62061 PFH <sub>D</sub> [1/h]	IEC 61511 SIL	IEC 61511 PFD	EN ISO 13849-1: 2006 T <sub>M</sub> [year]
Safety contacts, instantaneous	PL e	Cat. 4	SIL CL 3	2,31E-09	SIL 3	2,03E-06	20

All the units used within a safety function must be considered when calculating the safety characteristic data.



#### Information

A safety function's SIL/PL values are **not** identical to the SIL/PL values of the units that are used and may be different. We recommend that you use the PASCAL software tool to calculate the safety function's SIL/PL values.



#### ATTENTION!

It is essential to consider the relay's service life graphs. The relay outputs' safety-related characteristic data is only valid if the values in the service life graphs are met.

The PFH value depends on the switching frequency and the load on the relay output. If the service life graphs are not accessible, the stated PFH value can be used irrespective of the switching frequency and the load, as the PFH value already considers the relay's B10d value as well as the failure rates of the other components.

## Order reference

Order reference					
Product type	Features			Terminals	Order no.
PNOZ s4.1		24 VDC		Screw terminals	750 124
PNOZ s4.1 C		24 VDC		Spring-loaded terminals	751 124
PNOZ s4.1	48 - 240 VAC/DC			Screw terminals	750 154
PNOZ s4.1 C	48 - 240 VAC/DC			Spring-loaded terminals	751 154

## EC declaration of conformity

This product/these products meet the requirements of the directive 2006/42/EC for machinery of the European Parliament and of the Council. The complete EC Declaration of Conformity is available on the Internet at [www.pilz.com/downloads](http://www.pilz.com/downloads).

Representative: Norbert Fröhlich, Pilz GmbH & Co. KG, Felix-Wankel-Str. 2, 73760 Ostfildern, Germany

Мінск +375447584780 viber zakaz@pilz.by

МІНСК +375447584780 viber zakaz@igbt.by



...  
In many countries we are represented by our subsidiaries and sales partners.

Please refer to our homepage for further details or contact our headquarters.

### ► Technical support

+49 711 3409-444  
support@pilz.com



Pilz GmbH & Co. KG  
Felix-Wankel-Straße 2  
73760 Ostfildern, Germany  
Telephone: +49 711 3409-0  
Telefax: +49 711 3409-133  
E-Mail: pilz.gmbh@pilz.de  
Internet: www.pilz.com

# pilz