



E63

DC CAPACITORS



HERMETICAL CASE WITH AUTONOMOUS SAFETY MECHANISM

ELECTRONICON[®]
always in charge

Choose the best capacitor for any of your power electronics applications:

AC and DC capacitors with integrated safety mechanism
E62 AC/DC E62-3ph AC Filter E63 DC

Low-inductance capacitors
E50 PK16™ DC E53 AC/DC E61 DC

Low-inductance High-voltage capacitors
E51

AC and DC capacitors with large capacitance
E56 DC E59 AC/DC E70 AC E50.U SR17™ DC

CAPACITORS

ELECTRONICON®

always in charge

E63

DC CAPACITORS

WITH OVERPRESSURE PROTECTION

DC KONDENSATOREN MIT ÜBERDRUCKSICHERUNG





The special kind of films and coatings used in our E63-capacitors makes them interesting particularly for applications with high rms currents, e.g. as smoothing or supporting capacitors in buffer storage circuits. Filled with liquid resin, these capacitors have a high specific ratio of capacitance to volume. At the same time, they are extremely overvoltage proof. Very good self-healing characteristics and the integrated overpressure protection (break-action mechanism) ensure safe operation and controlled disconnection in the event of overload or failure at the end of operating life.

Die besondere Art der eingesetzten Folien und Beläge ermöglicht die hohe Stromtragfähigkeit unserer E63-Kondensatoren, was sie besonders für Anwendungen mit hohen Effektivströmen – z.B. als Glättungs- oder Stützkondensatoren in Zwischenkreisen - interessant macht. Die mit flüssigem Harz gefüllten Kondensatoren besitzen ein sehr günstiges Verhältnis von Kapazität zu Volumen, gleichzeitig sind sie außergewöhnlich überspannungsfest. Für einen sicheren Schutz bei Überlastung bzw. einen kontrollierten Ausfall am Ende der Lebensdauer sorgen ihre sehr gute Selbstheilfähigkeit sowie ein integrierter Überdruck-Unterbrecher.

DC-capacitors for General Use

Gleichspannungskondensatoren für allgemeine Anwendung

- Standards IEC 61071
optional IEC 61881
- can Gehäuse aluminium Aluminium
- mounting position Einbaulage... terminals pointing upwards stehend
- filling material Füllmittel..... liquid, based on vegetable oil, non-PCB
flüssig, auf Pflanzenölbasis, PCB-frei
- Internal protection break-action mechanism (BAM)
- Interne Sicherung Überdrucksicherung
- fire load Brandlast 40 MJ/kg



- C_N tolerance Toleranz ±10% (optional ±5%)
- insulation strength Isolationsgüte C × R_{is} 5000 s
- tanδ₀ 2 × 10⁻⁴
- operating temperatures Grenztemperaturen
 Θ_{min} ... Θ_{max} -25 ... +70°C
 Θ_{HOTSPOT} < 70°C
- storing temperature Lagertemperatur -40 ... +85°C
- Failure rate Ausfallrate 50 FIT
 reference service life_Referenzbetriebsdauer 100000 h, Θ_{HOTSPOT} <70°

C _N (μF)	R _s (mΩ)	L _e (nH)	R _{th} (K/W)	I _{max} (A)	I _h (kA)	I _s (kA)	E _N (Ws)	D ₁ × L ₁ (mm)	Design Maßbild	m (kg)	order no. Bestell-Nr.	pcs_Stk / Box
U _N 900V DC			U _s 1200V		U _r 200V		U _{TT} 1200V DC		U _{TC} 3000V AC			
100	7.1	100	10.5	19	0.92	2.76	40.5	50 × 85	G1	0.18	E63.G85-104G10	21 / FB2
175	5.7	100	7.2	25	1.60	4.80	70.9	65 × 95	G1	0.33	E63.L95-184G10	10 / FB2
250	2.1	130	5.0	43	2.29	6.87	101.3	85 × 105	L1	0.63	E63.N10-254L10	10 / FB10
680	1.9	130	2.7	43	6.23	18.69	275.4	95 × 176	L1	1.3	E63.P17-684L10	3 / FB8
800	1.8	130	2.5	43	7.33	20 *	324.0	100 × 176	L1	1.5	E63.Q17-804L10	3 / FB8
U _N 1200V DC			U _s 1800V		U _r 280V		U _{TT} 1800V DC		U _{TC} 3000V AC			
50	8.4	110	9.5	18	0.66	1.98	36.0	55 × 85	G1	0.21	E63.H85-503G10	18 / FB1
160	2.2	140	4.5	43	2.20	6.60	115.2	95 × 105	L1	0.78	E63.P10-164L10	6 / FB10
320	1.8	130	2.7	43	4.20	12.60	230.4	95 × 176	L1	1.3	E63.P17-324L10	3 / FB8
500	1.40	130	2.2	80	6.87	20 *	360.0	116 × 176	M1	2.0	E63.R17-504M10	3 / FB8
750	0.77	170	1.6	80	10.30	20 *	540.0	116 × 245	C6	2.7	E63.R24-754C60	3 / FB12
1000	0.73	170	1.7	100	13.74	20 *	720.0	136 × 245	C6	3.7	E63.S24-105C60	2 / FB12



E63.***

DC

1400...2000V



C _N (μF)	R _S (mΩ)	L _e (nH)	R _{th} (K/W)	I _{max} (A)	Î (kA)	I _S (kA)	E _N (Ws)	D ₁ × L ₁ (mm)	Design Maßbild	m (kg)	order no. Bestell-Nr.	pcs_Stk / Box
U_N 1400V DC		U_S 2100V			U_F 350V		U_{TT} 2100V DC		U_{TC} 3000V AC			
38	9.3	100	10.5	16	0.50	1.50	37.2	50 × 85	G1	0.2	E63.G85-383G10	21 / FB2
48	8.0	110	9.5	18	0.70	2.10	47.0	55 × 85	G1	0.2	E63.H85-483G10	18 / FB1
70	6.9	100	7.2	20	1.00	3.00	68.6	65 × 95	G1	0.3	E63.L95-703G10	10 / FB2
120	2.6	140	5.0	43	1.70	5.10	117.6	85 × 105	L1	0.6	E63.N10-124L10	10 / FB10
150	2.2	140	4.5	43	2.10	6.30	147.0	95 × 105	L1	0.8	E63.P10-154L10	6 / FB10
300	1.8	160	2.7	43	4.20	12.60	294.0	95 × 176	L1	1.3	E63.P17-304L10	3 / FB8
340	1.7	160	2.5	43	4.80	14.40	333.2	100 × 176	L1	1.5	E63.Q17-344L10	3 / FB8
480	1.30	160	2.2	80	6.80	20 *	470.4	116 × 176	M1	2.0	E63.R17-484M10	3 / FB8
500	1.10	170	1.6	80	8.01	20 *	490.0	116 × 245	M1	2.7	E63.R24-504M10	3 / FB12
990	0.94	170	1.7	100	14.10	20 *	970.2	136 × 245	C6	3.7	E63.S24-994C60	2 / FB12
1320	0.91	190	1.0	100	18.80	20 *	1293.6	136 × 320	C6	5.5	E63.S32-135C60	2 / FB13
U_N 1800V DC		U_S 2700V			U_F 400V		U_{TT} 2700V DC		U_{TC} 3600V AC			
20	11.9	100	10.5	15	0.41	1.23	32.4	50 × 85	G1	0.18	E63.G85-203G10	21 / FB2
54	3.5	140	5.7	35	1.00	3.00	87.5	75 × 105	C6	0.5	E63.M10-543C60	8 / FB0
66	3.2	140	5.0	40	1.20	3.60	106.9	85 × 105	C6	0.63	E63.N10-663C60	10 / FB10
190	1.5	160	2.5	80	3.60	10.80	307.8	100 × 176	C6	1.5	E63.Q17-194C60	3 / FB8
270	1.2	160	2.2	80	5.00	15.00	437.4	116 × 176	C6	2.0	E63.R17-274C60	3 / FB8
405	1.10	170	1.6	100	7.50	20 *	656.1	116 × 245	C6	2.7	E63.R24-414C60	3 / FB12
U_N 2000V DC		U_S 3000V			U_F 400V		U_{TT} 3000V DC		U_{TC} 4000V AC			
17	12.2	100	10.5	15	0.40	1.20	34.0	50 × 85	G1	0.18	E63.G85-173G10	21 / FB2
19	11.3	110	9.5	16	0.43	1.29	38.0	55 × 85	G1	0.21	E63.H85-193G10	18 / FB1
33	5.2	100	7.2	20	0.66	1.98	66.0	65 × 95	G1	0.33	E63.L95-333G10	10 / FB2
40	4.3	140	7.3	25	0.80	2.40	80.0	75 × 105	C6	0.5	E63.M10-403C60	8 / FB0
110	1.8	160	2.7	70	2.52	7.50	220.0	95 × 176	C6	1.3	E63.P17-114C60	3 / FB8
200	0.89	160	2.2	80	4.00	12.00	400.0	116 × 176	C6	2.0	E63.R17-204C60	3 / FB8
330	0.8	170	2.0	100	6.80	20 *	660.0	116 × 245	C6	2.7	E63.R24-334C60	3 / FB12
500	1.40	190	1.0	100	11.20	20 *	1000.0	136 × 320	C6	5.5	E63.S32-504C60	2 / FB13

E63.***
DC
2400...6300V

C_N (μ F)	R_s (m Ω)	L_e (nH)	R_{th} (K/W)	I_{max} (A)	\hat{I} (kA)	I_s (kA)	E_N (Ws)	$D_1 \times L_1$ (mm)	Design Maßbild	m (kg)	order no. Bestell-Nr.	pcs_Stk / Box
U_N 2400V DC		U_s 3600V		U_f 600V		U_{TT} 3600V DC		U_{TC} 4500V AC				
22	1.6	140	4.4	40	2.00	6.00	63.4	85 × 120	C6	0.9	E63.N12-223C60	10 / FB11
100	1.00	180	1.4	100	8.90	20 *	288.0	116 × 280	CR	3.1	E63.R28-104CR0	3 / FB11
180	0.81	180	1.2	100	15*	20 *	518.4	136 × 280	CR	4.3	E63.S28-184CR0	2 / FB11
330	1.2	240	1.0	80	9.00	20 *	950.4	136 × 320	C6	5.5	E63.S32-334C60	2 / FB13
U_N 3200V DC		U_s 4800V		U_f 600V		U_{TT} 4800V DC		U_{TC} 5600V AC				
16	3.2	140	3.9	40	1.93	5.79	81.9	95 × 120	CR	1	E63.P12-163CR0	3 / FB8
60	1.40	180	1.6	80	7.23	20 *	307.2	100 × 280	CR	2.6	E63.Q28-603CR0	3 / FB10
85	1.20	180	1.4	100	10.70	20 *	435.2	116 × 280	CR	3.1	E63.R28-853CR0	3 / FB11
120	1.10	180	1.2	100	14.80	20 *	614.4	136 × 280	CR	4.3	E63.S28-124CR0	2 / FB11
200	1.7	240	1.0	100	7.10	20 *	1024.0	136 × 320	CR	5.5	E63.S32-204CR0	2 / FB13
U_N 3600V DC		U_s 5400V		U_f 630V		U_{TT} 5400V DC		U_{TC} 6200V AC				
6.3	6.3	140	5.0	30	0.85	2.60	40.8	75 × 120	C6	0.8	E63.M12-632C60	10 / FB11
115	1.20	180	1.4	100	7.50	20 *	745.2	116 × 280	CR	3.1	E63.R28-1243C60	3 / FB11
90	1.2	180	1.2	100	12.64	20 *	583.2	136 × 280	CR	4.3	E63.S28-903CR0	2 / FB11
132	2.0	240	1.0	100	5.90	14.00	855.4	136 × 320	CR	5.5	E63.S32-134CR0	2 / FB13
U_N 4000V DC		U_s 6000V		U_f 630V		U_{TT} 6000V DC		U_{TC} 6800V AC				
14	4.6	140	4.4	30	1.00	3.00	112.0	85 × 120	C6	0.9	E63.N12-143C60	10 / FB11
50	1.40	180	1.4	100	7.20	20 *	400.0	116 × 280	CR	3.1	E63.R28-503CR0	3 / FB11
70	1.20	180	1.2	100	11.24	20 *	560.0	136 × 280	CR	4.3	E63.S28-703CR0	2 / FB11
U_N 6300V DC		U_s 10000V		U_f 700V		U_{TT} 9450V DC		U_{TC} 10000V AC				
22	7.2	170	1.8	40	1.51	4.53	436.6	100 × 245	CR	2.4	E63.Q24-223CR0	3 / FB10
45	4.0	170	1.3	60	3.00	9.00	893.0	136 × 245	CR	3.7	E63.S24-453CR0	2 / FB12



E63.***

DC

900...6300V





B2

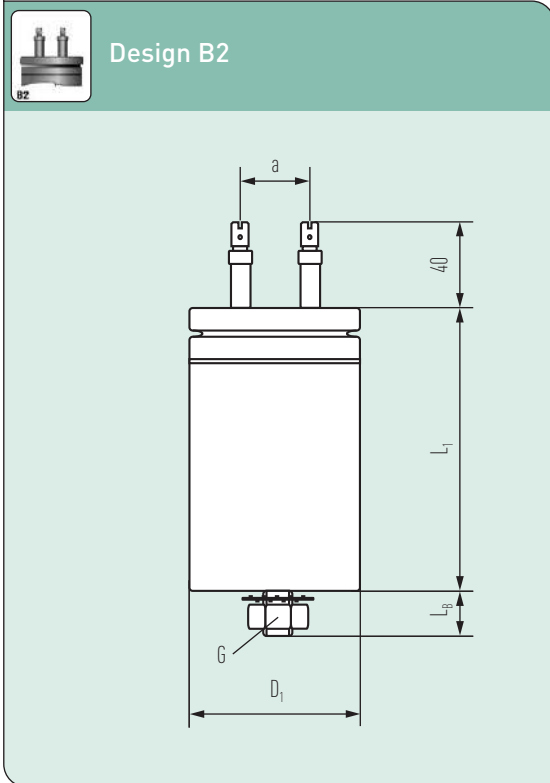

Design B2

CAPACITORS WITH A CAN DIAMETER OF 45...55 mm

- Can material aluminium
- Base mounting stud see chart
- Lid brass with rubber sealing, flanged can
- Terminals single tab connector 6.3 x 0.8 mm on
..... soldered ceramic bushing
- I_{max} (Terminals) 16 A
- Degree of protection IP 00
- Humidity class F

KONDENSATOREN MIT EINEM GEHÄUSEDURCHMESSER VON 45...55 mm

- Gehäusematerial Aluminium
- Bodenschraube siehe Tabelle
- Deckel Messing, Bördelverschluss
..... mit Gummidichtung
- Anschlüsse Flachstecker 6.3 x 0.8 mm auf eingelöteter
..... Keramikdurchführung
- I_{max} (Anschlüsse) 16 A
- Schutzgrad IP 00
- Feuchteklasse F

D_1	L_b	G	a	K	L
45	10	M8	19	20	9
50	16	M12	26	20	16
55	16	M12	26	20	16



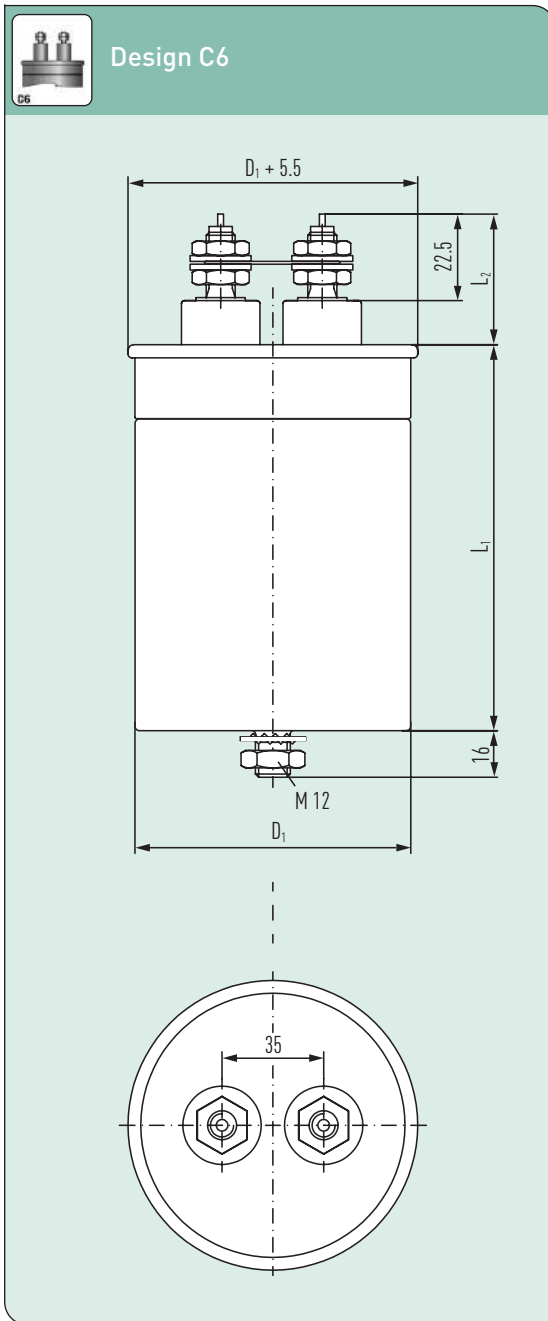

CAPACITORS WITH A CAN DIAMETER OF 75...136 mm

- Can material aluminium
- Base mounting stud M12
- Lid flanged aluminium (folded edge)
- Terminals threaded stud M10 on soldered
..... plastic bushing
- I_{max} (Terminals) 100 A
- Degree of protection IP 00
- K 25 mm
- L 15 mm
- Humidity class C

KONDENSATOREN MIT EINEM GEHÄUSEDURCHMESSER VON 75...136 mm

- Gehäusematerial Aluminium
- Bodenschraube M12
- Deckel Aluminium, Bördelverschluss
- Anschlüsse Gewindebolzen M10 auf eingelöteter
..... Kunststoffdurchführung
- I_{max} (Anschlüsse) 100 A
- Schutzgrad IP 00
- K 25 mm
- L 15 mm
- Feuchteklasse C

D_1	L_2
75	45
85	45
95	45
100	45
116	41
136	41



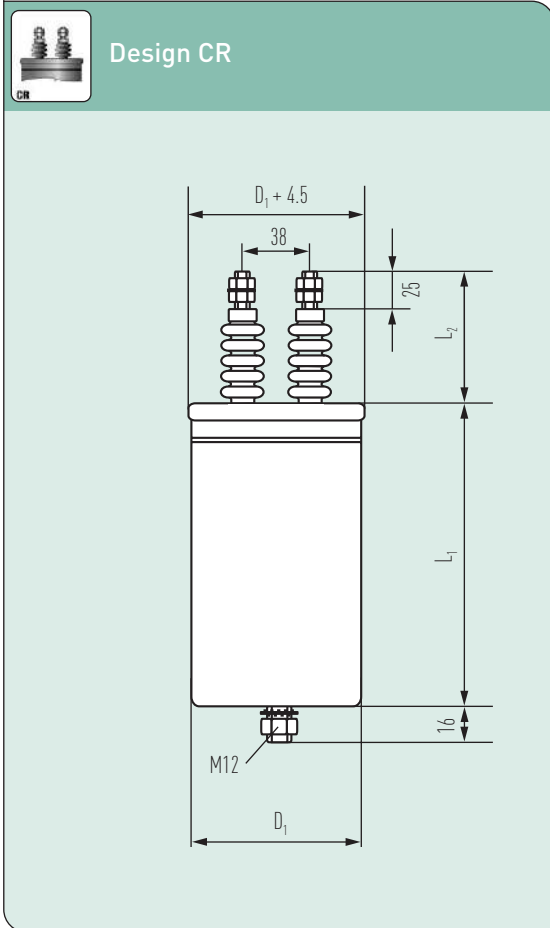

CAPACITORS WITH A CAN DIAMETER OF 75...136 mm

- Can material aluminium
- Base mounting stud M12
- Lid flanged copper (folded edge)
- Terminals threaded stud M10 on soldered ceramic
..... bushing
- I_{max} (Terminals) 100 A
- Degree of protection IP 00
- K 54 mm
- L 17 mm
- Humidity class C

KONDENSATOREN MIT EINEM GEHÄUSEDURCHMESSER VON 75...136 mm

- Gehäusematerial Aluminium
- Bodenschraube M12
- Deckel Kupfer, Bördelverschluss
- Anschlüsse Gewindebolzen M10 auf eingelöteter
..... Keramikdurchführung
- I_{max} (Anschlüsse) 100 A
- Schutzgrad IP 00
- K 54 mm
- L 17 mm
- Feuchteklasse C

D_1	L_2
75	55
85	55
95	55
100	55
116	55
136	52





G1

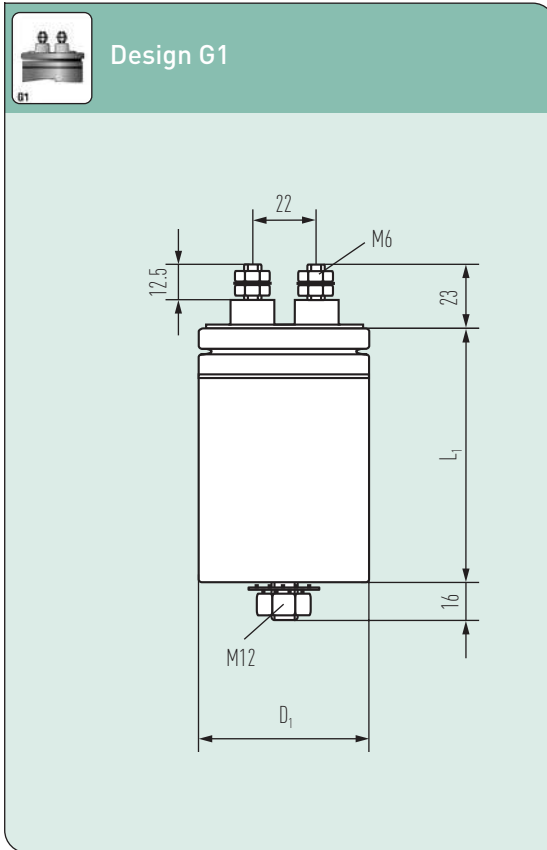

Design G1

CAPACITORS WITH A CAN DIAMETER OF 50/55/65 mm

- Can material aluminium
- Base mounting stud M12
- Lid plastic with rubber sealing, flanged can
- Terminals threaded stud M6 on integrated plastic
..... bushing
- I_{max} (Terminals) 40 A
- Degree of protection IP 00
- L 10
- Humidity class F

KONDENSATOREN MIT EINEM GEHÄUSEDURCHMESSER VON 50/55/65 mm

- Gehäusematerial Aluminium
- Bodenschraube M12
- Deckel Kunststoff, Bördelverschluss
..... mit Gummidichtung
- Anschlüsse Gewindebolzen M6 auf integrierter
..... Kunststoffdurchführung
- I_{max} (Anschlüsse) 40 A
- Schutzgrad IP 00
- L 10
- Feuchteklasse F

D_1	K
50	15
55	16
65	21



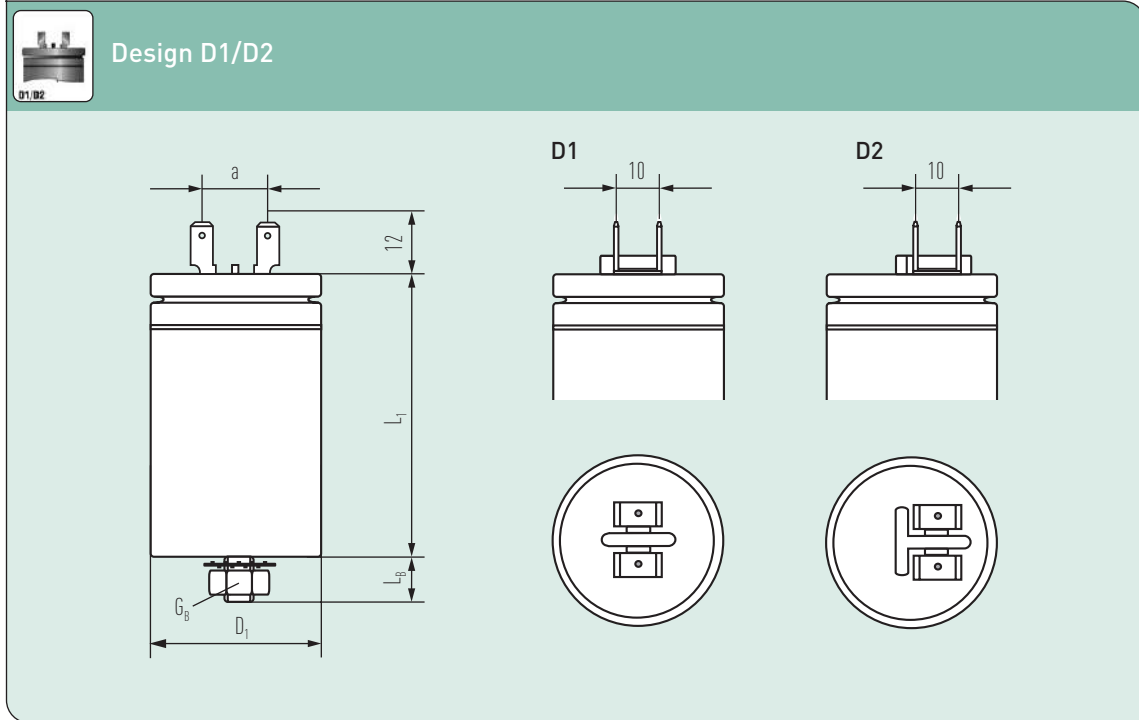

D1 CAPACITORS WITH A CAN DIAMETER OF 35...60 mm

D2 CAPACITORS WITH A CAN DIAMETER OF 65...75 mm

- Can material aluminium
- Base mounting stud see chart
- Lid plastic with rubber sealing, flanged can
- Terminals dual tab connectors 6.3 x 0.8 mm
..... (tinned steel, riveted)
- I_{max} (Terminals) 16 A
- Degree of protection IP 00
- Humidity class F

D1 KONDENSATOREN MIT GEHÄUSEDURCHMESSER 35...60 mm

D2 KONDENSATOREN MIT GEHÄUSEDURCHMESSER 65...75 mm

- Gehäusematerial Aluminium
- Bodenschraube siehe Tabelle
- Deckel Kunststoff, Bördelverschluss mit
..... Gummidichtung
- Anschlüsse Doppelfachstecker 6.3 x 0.8 mm
..... (verzinnter Stahl, genietet)
- I_{max} (Anschlüsse) 16 A
- Schutzgrad IP 00
- Feuchteklasse F

D_1	a	G_B	L_B	K	L
35	13.5	M8	10	6.5	6.5
40	13.5	M8	10	9	6.5
45	13.5	M8	10	10	6.5
50	13.5	M12	16	10	6.5
55	13.5	M12	16	10	6.5
60	13.5	M12	16	10	6.5
65	16.5	M12	16	10	8
75	16.5	M12	16	10	8



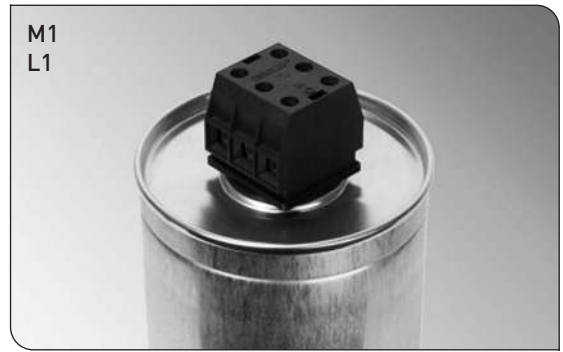

Design K / L / M
CAPAGRIP™

(* $D_1 = 136: +6$)

M1
L1

K1

CAPACITORS WITH A CAN DIAMETER OF 60...136 mm

- Can material aluminium
 Base mounting stud M12
 Lid flanged aluminium (folded edge)
Terminals
 L1 2 x 25 mm² per contact¹⁾
 M1 2 x 50 mm² per contact¹⁾
 K1 1 x 10 mm² per contact¹⁾
I_{max} (Terminals)
 L1 56 A
 M1 104 A
 K1 39 A
Degree of protection IP 20
 K 16 mm
 L 16 mm
Humidity class C

KONDENSATOREN MIT EINEM GEHÄUSEDURCHMESSER VON 60...136 mm

- Gehäusematerial Aluminium
 Bodenschraube M12
 Deckel Aluminium, Bördelverschluss
Anschlüsse
 L1 2 x 25 mm² pro Kontakt¹⁾
 M1 2 x 50 mm² pro Kontakt¹⁾
 K1 1 x 10 mm² pro Kontakt¹⁾
I_{max} (Anschlüsse)
 L1 56 A
 M1 104 A
 K1 39 A
Schutzgrad IP 20
 K 16 mm
 L 16 mm
Feuchteklasse C

1) For design K1, L1 and M1 the central screw has no contact. Bei den Ausführungen K1, L1 und M1 hat die mittlere Klemme keinen Kontakt.

	Design L1	Design M1	Design K1
h	35	45	26
b	42	49	38
t	44	55	35.5



Important Remarks

General

Our catalogues outline the typical technical and mechanical characteristics of the listed capacitors. The stated values are based on reference type tests, as well as empirical and experimental experience. The real values of individual capacitors may differ within the stated, or commonly known, tolerances. Any information given in this catalogue therefore describes the components in general terms and does not constitute any guarantee of individual technical values.

It is the responsibility of the user to ensure by dedicated tests the suitability and safety of operation of our components under the conditions of his application. This also applies to any accessories offered by ELECTRONICON.

Safety

Safe operation of the capacitors can be expected only if all safety recommendations as well as electrical and thermal specifications as stated on the label, in the data sheets, catalogues and the accompanying mounting instructions are strictly observed, and recommended safety devices are used as intended. Please consider the "General Safety Recommendations" of the power capacitor manufacturers organized in the German ZVEI (www.electronicon.com/en/zvei).

The capacitors shall only be used for the intended application. ELECTRONICON will not indemnify or be responsible for any kind of damages to persons or property due to the improper application of any capacitors purchased from ELECTRONICON or its distributors.

Mind that electrical or mechanical misapplication of capacitors can become hazardous. Misapplied capacitors can explode or catch fire and cause bodily injury or property damage due to the expulsion of material or metal fragments.

Please consult the detailed instructions for mounting and application stated in our brochure „Application Notes“ and on the ELECTRONICON website: www.electronicon.com/en/an

If in doubt about how to connect, operate, or discharge a capacitor, consult ELECTRONICON engineering or our distributors.

Mounting And Cooling

The useful life of a capacitor may be reduced dramatically if exposed to excessive heat. Typically an increase in the ambient temperature of 7°C will halve the expected life of the capacitor. Make sure to obey the permitted operating temperatures.

To avoid overheating the capacitors must be allowed to cool unhindered and should be shielded from external heat sources. We recommend forced ventilation for all filter applications with reactors. Give approx. 20mm clearance around capacitors for natural or forced ventilation, and do not place them directly above or next to heat sources such as detuning or tuning reactors, bus bars, etc.

Wichtige Hinweise

Allgemeines

Unsere Kataloge beschreiben die typischen technischen und mechanischen Eigenschaften der aufgeführten Kondensatoren. Die angegebenen Werte basieren auf Referenztypprüfungen sowie empirischen und experimentellen Erfahrungswerten. Die tatsächlichen Werte einzelner Kondensatoren können innerhalb der angegebenen bzw. allgemein bekannter Toleranzen abweichen. Alle Angaben in diesem Katalog beschreiben daher die Komponenten im Allgemeinen und stellen keine Garantie für individuelle technische Werte dar.

Es liegt in der Verantwortung des Anwenders, durch gezielte Prüfungen die Eignung und Betriebssicherheit unserer Komponenten unter den konkreten Betriebsbedingungen seiner Anwendung sicherzustellen. Dies gilt ebenso für gegebenenfalls von ELECTRONICON angebotene Zubehörteile.

Sicherheit

Ein sicherer Betrieb der Kondensatoren ist nur zu erwarten, wenn alle Sicherheitsempfehlungen sowie elektrische und thermische Spezifikationen entsprechend Etikett, Datenblättern, Katalogen und beiliegenden Montageanleitungen eingehalten und die empfohlenen Sicherheitseinrichtungen bestimmungsgemäß verwendet werden. Bitte beachten Sie die „Allgemeinen Sicherheitsempfehlungen“ der im deutschen ZVEI organisierten Hersteller von Leistungskondensatoren (www.electronicon.com/zvei).

Die Kondensatoren dürfen ausschließlich für ihren Bestimmungszweck verwendet werden. ELECTRONICON übernimmt keine Verantwortung oder Haftung für Schäden an Personen oder Eigentum, welche aus unsachgemäßer Anwendung von Kondensatoren herrührt.

Elektrisch oder mechanisch fehlerhaft eingesetzte Kondensatoren können explodieren oder Feuer fangen. Austretende Materialien bzw. Metallteile können gesundheitliche und materielle Schäden verursachen.

Bitte beachten Sie die detaillierten Anweisungen in unserer Broschüre „Anwendungshinweise“ sowie auf der Webseite von ELECTRONICON: www.electronicon.com/an

Bitte konsultieren Sie das Fachpersonal oder unsere Distributoren zu Fragen bezüglich Anschluss, Verwendung oder Entladung von Kondensatoren.

Montage und Kühlung

Die Lebensdauer eines Kondensators kann durch übermäßige Wärmeeinwirkung erheblich verringert werden. Im allgemeinen führt eine Erhöhung der Umgebungstemperatur um 7°C zu einer Verringerung der Lebensdauer des Kondensators um 50 %. Halten Sie die zugelassenen Betriebstemperaturen ein.

Um Überhitzung zu vermeiden, muß gewährleistet sein, daß die Kondensatoren auftretende Verlustwärme ungehindert abführen können und vor fremden Wärmequellen abgeschirmt werden. Insbesondere in Filtern ist in jedem Falle eine Zwangslüftung zu empfehlen. Zwischen und um Kondensatoren sollten etwa 20mm Platz für natürliche oder Zwangslüftung belassen werden. Bringen Sie den Kondensator nie direkt neben oder über Wärmequellen, wie Drosseln u. ä. an.



ANNEX
ANHANG

Failure Rate

The failure probability of a component is a statistical value which is described by a log-normal distribution:

Ausfallrate

Die Ausfallwahrscheinlichkeit eines Bauelements ist eine statistische Größe, die mit Hilfe einer Normalverteilung beschrieben wird. Es gilt:

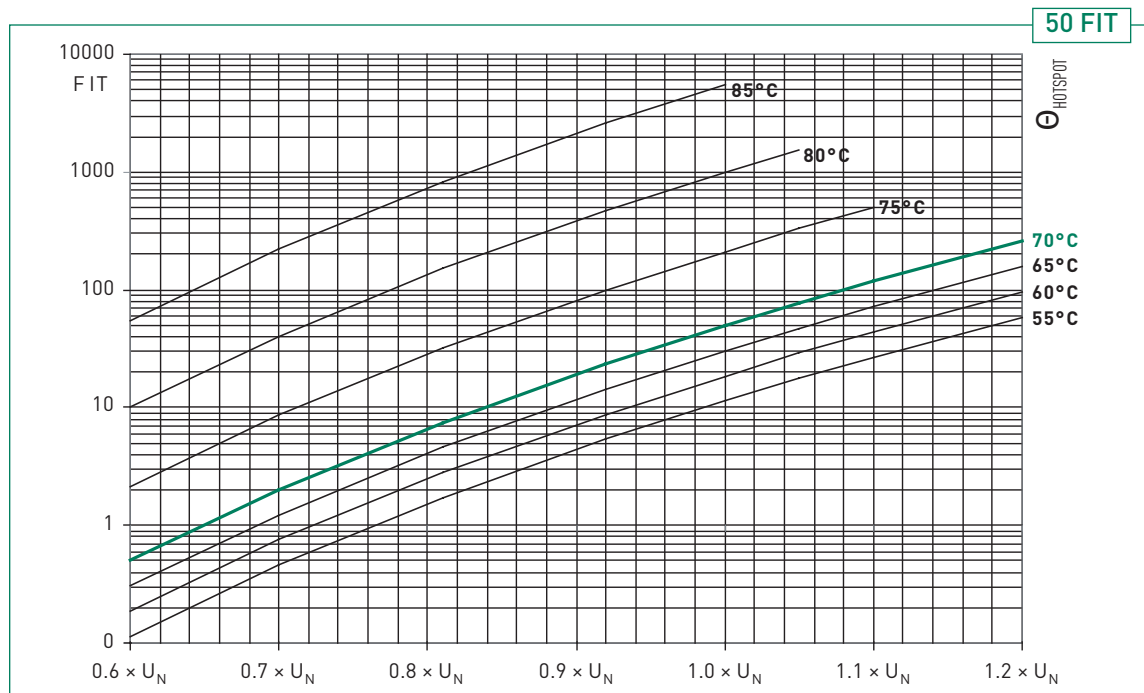

$$N = N_0 \times e^{-\lambda t}$$

- N = number of functional components after period t
Anzahl der nach der Zeit t intakten Bauelemente
- N₀ = total number of components at time t = 0
Gesamtzahl der Bauelemente zum Zeitpunkt t = 0
- λ = failure rate Ausfallrate

λ is the failure rate, which alternatively is also stated as the so-called FIT-rate (FIT = Failures In Time = λ × 10⁹).

Dabei ist λ die Ausfallrate, die alternativ auch als FIT-Rate angegeben wird (FIT = λ × 10⁹)

The failure rate is very closely linked with operating temperature and operating voltage of the capacitor. The FIT rates stated in this catalogue are related to the capacitor's rated voltage and a dielectric temperature (= HOTSPOT temperature) of 70°C.

Die Ausfallrate ist stark abhängig von der Temperatur und der Betriebsfeldstärke. Die FIT-Raten im Katalogsortiment beziehen sich auf 70°C Dielektrikumstemperatur (=Hotspot-Temperatur) und die Nennspannung des Kondensators.

The simultaneous operation of capacitors at highest permissible voltage and operating temperature should be avoided; otherwise, failure rates may increase beyond reasonable technical reliability.

Der Betrieb von Kondensatoren mit der höchsten zulässigen Spannung und der höchsten zulässigen Betriebstemperatur sollte vermieden werden, andernfalls können die Ausfallraten so hoch werden, dass keine technisch sinnvollen Zuverlässigkeiten mehr gewährleistet sind.

The standard reference period for the failure rate statement is 100.000 hours. Please note that FIT rates can be altered or improved by technical adjustments. Please contact us for details.

Der Wert für die Ausfallrate bezieht sich auf einen Referenzzeitraum von 100.000h. FIT-Raten können durch technische Anpassung der Kondensatoren beeinflusst und verbessert werden. Auskünfte hierzu erteilen wir auf Anfrage.

The following diagram demonstrates the correlation between FIT rate, operating voltages and operating temperatures.

Das nachstehende Kurvendiagramm macht den Zusammenhang von FIT-Rate, Betriebsspannung und Betriebstemperatur deutlich.



Important Remarks

Functioning of the BAM™ (Break Action Mechanism)

In the event of overvoltage or thermal overload or ageing at the end of the capacitor's useful service life, an increasing number of selfhealing breakdowns may cause rising pressure inside the capacitor.

To prevent it from bursting, the capacitor is fitted with an obligatory „break action mechanism“ (BAM™).

The BAM™ is based on an attenuated spot at one or both of the connecting wires inside the capacitor. With rising pressure the case begins to expand, mainly by opening the folded crimp and pushing the lid upwards. As a result, the prepared connecting wire is separated at the attenuated spot, and the current path is interrupted irreversibly.

Wichtige Hinweise

Funktion der Abreißsicherung (BAM™)

Bei spannungsmäßiger oder thermischer Überlastung bzw. am Ende der Lebensdauer kann durch zahlreiche Selbstheilungsdurchschläge ein Überdruck im Kondensator entstehen.

Um ein Bersten der Gehäuse zu verhindern, sind die Kondensatoren generell mit einer Überdruck-Abreißsicherung (BAM™) versehen.

Diese Sicherung besteht aus einer Sollbruchstelle in einem oder beiden Anschlussdrähten. Bei einem Überdruck im Kondensator verlängert sich das Gehäuse durch das Öffnen der gestauchten Sicke bzw. Wölbung des Metalldeckels und die Stromzufuhr zu den Kondensatorwickeln wird an den Sollbruchstellen irreversibel unterbrochen.

Principle of the break action mechanism (exemplaric sketch)
Prinzip der Überdruck-Abreißsicherung (Prinzipskizze)

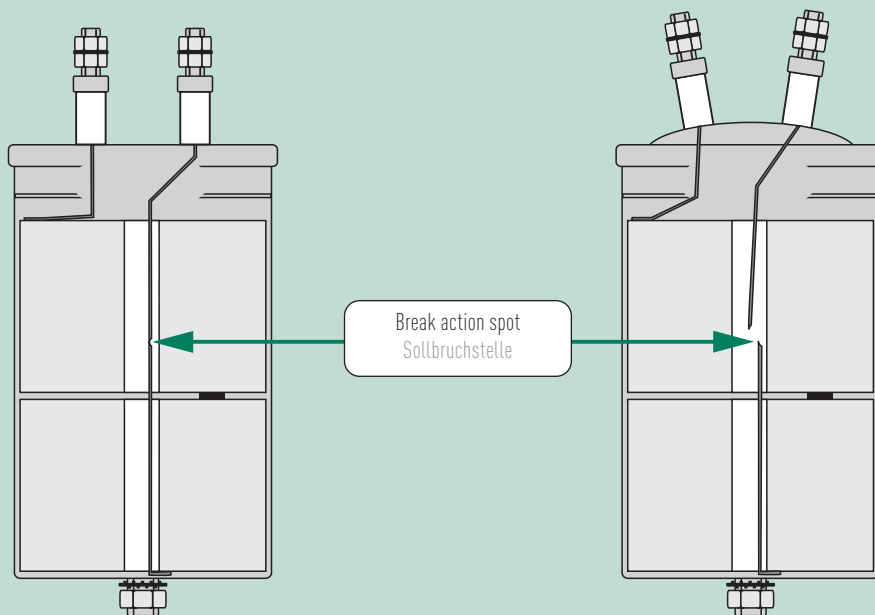

Capacitor before functioning of the BAM
Kondensator vor dem Abschalten durch die Überdruck-Abreißsicherung

Capacitor after functioning of the BAM
Kondensator nach dem Abschalten durch die Überdruck-Abreißsicherung

Warning:

It has to be noted that this safety system can act properly only within the permitted limits of loads and overloads. The simple presence of a safety mechanism does not mean that catastrophic failures are completely impossible. Strong overvoltages, permanent external heat, and heavy current overload, e.g. during harmonic resonances may cause sudden, uncontrollable rise of temperature and pressure inside the can which may not leave sufficient time for the BAM™ to act properly, and result in explosion and fire.

For more detailed information, please consult our "Application Notes" and the „General Safety Advice for Power Capacitors“ issued by the German Electrical and Electronic Manufacturer's Association (ZVEI).

Warnung:

Es ist zu beachten, daß dieses Sicherungsprinzip nur innerhalb der zulässigen Be- und Überlastungsgrenzen zuverlässig wirken kann. Die Existenz eines Sicherheitsmechanismus an sich bedeutet nicht, dass gewaltsame Ausfälle gänzlich ausgeschlossen werden können. Starke Überspannungen, andauernde äußere Wärmeeinwirkung sowie starke Überstrombelastung, z.B. während Oberwellenresonanzen, können plötzlichen unkontrollierten Temperatur- und Druckanstieg im Kondensatorinnern hervorrufen, welche der Überdrucksicherung nicht ausreichend Zeit zum ordnungsgemäßen Abschalten lassen und zur Explosion bzw. Entzündung führen können.

Für detailliertere Informationen konsultieren Sie bitte unsere ausführliche Broschüre „Anwendungshinweise“ sowie die „Allgemeinen Sicherheitshinweise für Leistungskondensatoren“ des ZVEI.

ANNEX ANHANG

Protection against Overvoltages And Short Circuits: Self-Healing Dielectric

All dielectric structures used in our power capacitors are „selfhealing“: In the event of a voltage breakdown the metal layers around the breakdown channel are evaporated by the temperature of the electric arc that forms between the electrodes. They are removed within a few microseconds and pushed apart by the pressure generated in the centre of the breakdown spot. An insulation area is formed which is reliably resistive and voltage proof for all operating requirements of the capacitor. The capacitor remains fully functional during and after the breakdown.

For voltages within the permitted testing and operating limits the capacitors are short-circuit- and overvoltage-proof. They are also proof against external short circuits as far as the resulting surge discharges do not exceed the specified surge current limits.

Limited Warranty

All our products are designed, manufactured, and tested with the highest care and workmanship. The satisfaction of our customers is our highest goal. We therefore warrant remedying any defect in the goods resulting from faulty design, materials or workmanship, which appears within 3 years from the date of sale, unless agreed otherwise.

This warranty does not cover defects due to improper use of the goods or operation at conditions exceeding the rated values stated in the catalogue or special data sheet. Nor does it cover defects due to faulty maintenance or incorrect installation, alterations or faulty repairs undertaken by the Buyer. Finally the warranty does not cover normal wear and tear or deterioration.

See our „General Conditions“ for details on Warranty and Product liability.

Schutz gegen Überspannungen und Kurzschlüsse: Selbstheilendes Dielektrikum

Alle in unseren Leistungskondensatoren eingesetzten dielektrischen Strukturen sind selbstheilend. Im Falle eines Kurzschlusses (Spannungsdurchschlag) verdampfen die Metallbeläge um den Durchschlagpunkt herum infolge des Lichtbogens, der sich zwischen den Elektroden bildet. Binnen Mikrosekunden wird der Metaldampf vom Zentrum des Durchschlages weggedrückt. Auf diese Weise bildet sich eine isolierende belagfreie Zone um den Durchschlagpunkt. Der Kondensator bleibt während und nach dem Durchschlag voll funktionsfähig.

Für Spannungen innerhalb der zugelassenen Test- und Betriebsbedingungen sind die Kondensatoren kurzschluss- und überspannungssicher. Sie sind außerdem sicher gegen äußere Kurzschlüsse, sofern bei den dabei entstehenden Stoßentladungen die zugelassenen Stoßströme nicht überschritten werden.

Gewährleistung

Alle unsere Erzeugnisse werden mit höchster Sorgfalt und Fachkenntnis entwickelt, hergestellt und geprüft. Die Zufriedenheit unserer Kunden ist unser höchstes Ziel. Wir verpflichten uns daher, sofern nicht anders vereinbart, jeden innerhalb von 3 Jahren ab Verkaufsdatum auftretenden Mangel an unseren Erzeugnissen zu beseitigen, welcher aus Fehlern in Design, Material oder Herstellung herrührt.

Diese Gewährleistung erstreckt sich nicht auf Defekte infolge unsachgemäßer Anwendung oder Betrieb außerhalb der nach Katalog oder Datenblatt zulässigen Einsatzbedingungen. Sie erfaßt ebensowenig Schäden aufgrund fehlerhafter Wartung, unsachgemäßer Montage, Änderungen oder unsachgemäßer Reparaturen durch den Käufer bzw. Anwender. Diese Gewährleistung betrifft auch nicht normale Abnutzung und Verschleiß.

Siehe unsere „Allgemeinen Geschäftsbedingungen“ für Details zu Gewährleistung und Produkthaftung.

Find more information and detailed instructions in our „Application Notes“ and on www.electronicon.com
Mehr Informationen und ausführliche Anweisungen finden Sie in unseren „Anwendungshinweisen“ und unter www.electronicon.com

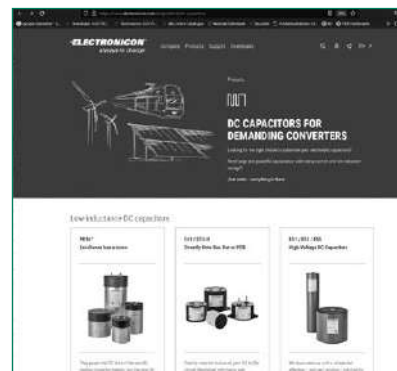
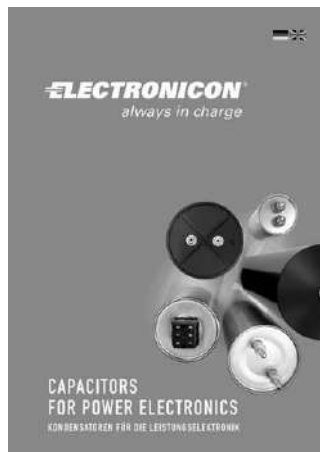

CAPACITORS FOR APPLICATIONS IN POWER ELECTRONICS

www.electronicon.com



E51/E53/E55
AC/DC FILM CAPACITORS



HIGH VOLTAGES, HEAVY CURRENTS, AND LOW INDUCTANCE

ELECTRONICON
always in charge

www.electronicon.com



E57/E59/SR17™ AC AND DC CAPACITORS
WITH LARGE CAPACITANCES



STANDARD OR SPECIAL – YOUR CHOICE

ELECTRONICON
always in charge

www.electronicon.com Issue 04/2023



DC CAPACITORS
DC KONDENSATOREN



ELECTRONICON
always in charge

www.electronicon.com



E62 AND E64
HEAVY DUTY AC CAPACITORS



THE PERFECT CHOICE FOR YOUR AC/DC APPLICATION

ELECTRONICON
always in charge

www.electronicon.com



E62-3ph AND 3HF
HEAVY DUTY THREE PHASE AC FILTER CAPACITORS



HIGH-END FOR THE HEART OF YOUR AC FILTER

ELECTRONICON
always in charge

www.electronicon.com



PEC APPLICATION NOTES / ANWENDUNGSHINWEISE



ELECTRONICON
always in charge

always in charge

EXCELLENT EXPERIENCE IN CAPACITOR MAKING FOR OVER 80 YEARS

Gera has been a centre of capacitor making since 1938. ELECTRONICON Kondensatoren GmbH which emerged from previous RFT/VEB ELEKTRONIK Gera in 1992, has become one of Europe's leading capacitor manufacturers supplying customers worldwide and being an open and competent partner for manufacturers and users of power factor correction equipment, for many manufacturers of drives, power electronics, home appliances, and for the lighting industry. Regular investments in advanced and environmentally sound technologies guarantee the highest levels in manufacture and quality to modern standards which are approved and monitored by leading certification authorities.

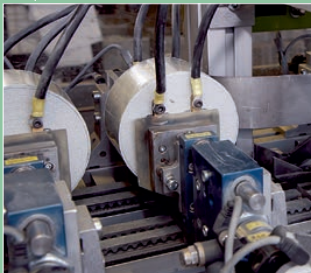

- In today's globalised competition, we distinguish ourselves by
- Absolute reliability and safety of our products
 - Close co-operation between manufacturer and client to meet both technical and commercial requirements
 - Improvement and development of our technical expertise in capacitor design and manufacture, as well as film coating, with special attention paid to the MKPg-technology
 - Early identification and incorporation of new trends and methods in the manufacturing of capacitors
 - Flexibility and punctual fulfilment of our commercial obligations

Our experienced development engineers are competent and responsible for both implementing the latest technical trends applicable to our products and ensuring that our products adapt to the challenges of traditional and new markets.

The close and intense co-operation between the departments of Marketing & Sales, Research & Development, and Production has become the keystone of our success. ELECTRONICON is continually striving to establish a similarly close and interactive relationship with its distributors and direct clients both in home and overseas markets, to become not just one out of many suppliers, but your preferred partner for ideas and solutions.

ELECTRONICON®

Germany • 07549 Gera • Keplerstrasse 2
Fon +49 365 / 734 61 00 • Fax +49 365 / 734 61 10
E-Mail: sales@electronicon.com, www.electronicon.com



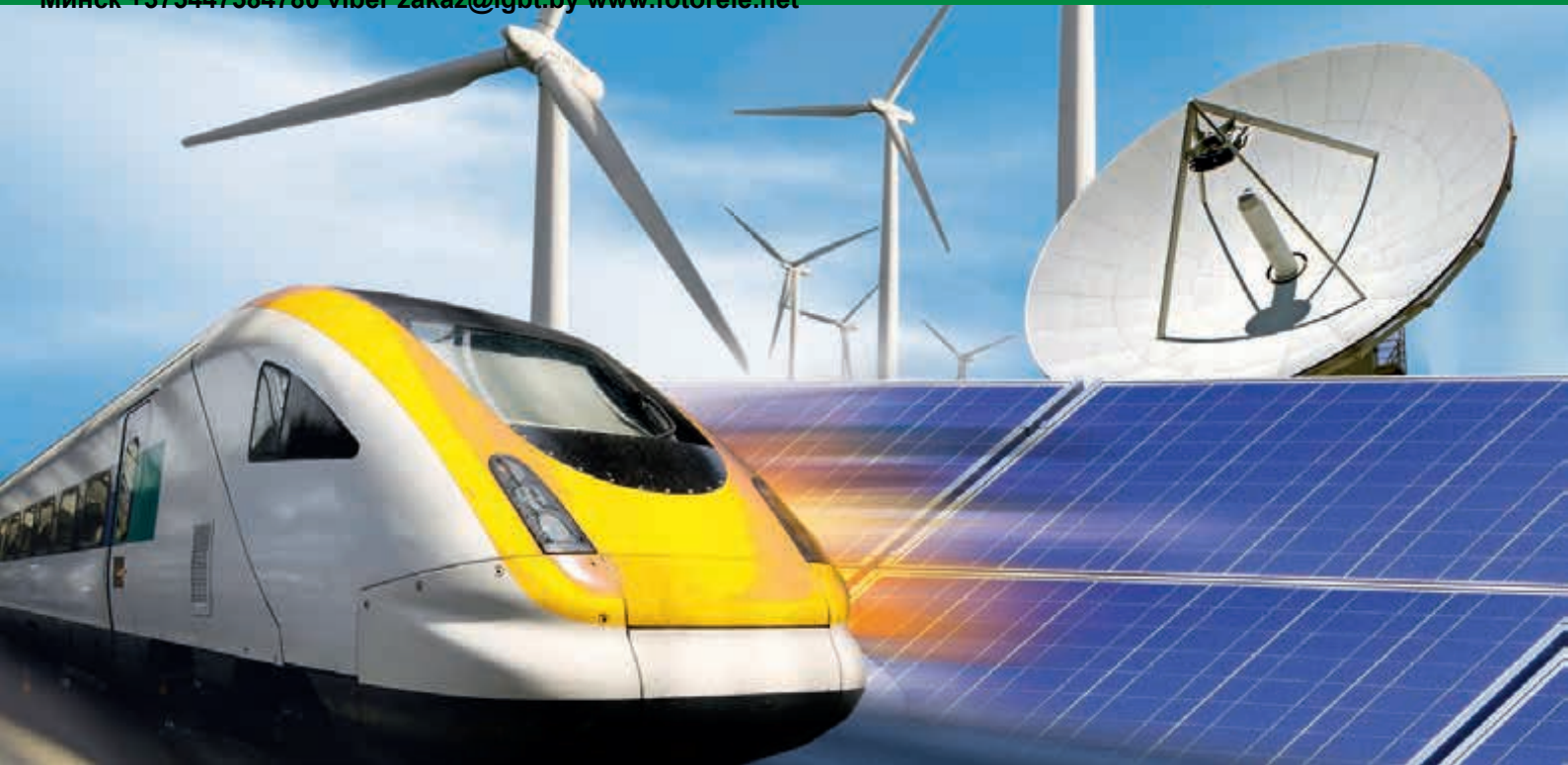

DC CAPACITORS

DC KONDENSATOREN



ELECTRONICON®
always in charge

www.electronicoh.com Issue 12/2023

E57 / E59 / SR17™
AC AND DC CAPACITORS
WITH LARGE CAPACITANCES

STANDARD OR SPECIAL – YOUR CHOICE

ELECTRONICON
always in charge

www.electronicoh.com Issue 04/2024

DC CAPACITORS
DC KONDENSATOREN

ELECTRONICON
always in charge

www.electronicoh.com Issue 04/2024

E51 / E53 / E55
INDUCED KERN CAPACITORS

HIGH VOLTAGE, HIGH CURRENTS AND LOW INDUCTANCE

ELECTRONICON
always in charge

CAPACITORS FOR POWER ELECTRONICS

www.electronicoh.com Issue 05/2023

DC CAPACITORS

HERMETICAL CASE WITH AUTONOMOUS SAFETY MECHANISM

ELECTRONICON
always in charge

www.electronicoh.com Issue 03/2024

E62-3ph and 3HF
HEAVY DUTY THREE PHASE AC FILTER CAPACITORS

HIGH-END FOR THE HEART OF YOUR AC FILTER

ELECTRONICON
always in charge

www.electronicoh.com

E62 and E64
HEAVY DUTY AC CAPACITORS

THE PERFECT CHOICE FOR YOUR AC/DC APPLICATION

ELECTRONICON
always in charge

COMPONENTS FOR POWER FACTOR CORRECTION

www.electronicoh.com Issue 04/2024

KEY COMPONENTS FOR POWER FACTOR CORRECTION
IN 50Hz MAINS

FACTORY MATCHED
TO OPERATE IN PERFECT HARMONY

ELECTRONICON
always in charge

www.electronicoh.com

MSD™ FKD-MV™ DSC™
MEDIUM VOLTAGE CAPACITORS
AND REACTORS

THE ECO-FRIENDLY ALTERNATIVE

ELECTRONICON
always in charge

ELECTRONICON
always in charge

CAPACITORS FOR POWER ELECTRONICS
KONDENSATOREN FÜR DIE LEISTUNGSELEKTRONIK

DC CAPACITORS

DC KONDENSATOREN

E67 GA85	Extremely Low Inductance, Individual Protection Device, Climate Proof 4 - 9 Extrem niedrige Induktivität, eigene Sicherung, klimafest
E50 PK16™	The Industrial Standard: Low Inductance and High Capacitance Density 10 - 19 Der Industriestandard: niedrige Induktivität und hohe Kapazitätsdichte
E80 PK mind®	Fit For SiC: Ultra-Low Inductance and Constant ESR 20 - 25 Ideal für SiC: Ultraniedrige Induktivität und konstanter ESR
E61	Directly Onto Bus Bar or PCB: High Currents and Low Inductance 26 - 32 Direkt auf Sammelschiene oder Leiterplatte: hohe Ströme und niedrige Induktivität

Е6



Mesis®



EN 45545



ultra low



85/85
-50°C



RU[®]
C US

GA85 - EXTREMELY LOW INDUCTANCE, INDIVIDUAL PROTECTION DEVICE, CLIMATE PROOF EXTREM NIEDRIGE INDUKTIVITÄT, EIGENE SICHERUNG, KLIMAFEST





Extremely Low Self-Inductance and Reliable Protection: E67 GA85 Mesis®

Unwanted inductances may cause significant disturbances in high-current DC link circuits (so-called voltage overshoot). This may result in substantial damage.

This is countered on the one hand by perfecting the interconnection (sandwich busbars, which neutralize their own inductance to a large extent); on the other hand, the self-inductance of the capacitor plays a very important role as well. This challenge is all the greater in DC links with high switching frequencies or those with large capacitance requirements. The classic solution - very flat capacitors as close as possible to the bus bar - is only of limited use due to space and cost reasons.

The particularly low self-inductance and low-loss design of our new GA85 E67 DC capacitors take this problem into account. The version with two terminals offers self-inductances below 55 nH even with large capacitances in cases with a height of 280mm; with four terminals in crosswise arrangement, even 10 nH can be achieved in shorter cans. In a combination of several units, values previously unknown can be created.

The capacitors are tightly sealed by metallic cases and lids. They are therefore extremely well shielded against environmental influences such as moisture or contamination by harmful substances. Temporary condensation on these capacitors is just as permissible as IEC humidity tests under extreme conditions with 85% RH at 85°C.

The E67s are the world's first capacitors to feature our innovative Mesis® overpressure protection. Just like our BAM, which has been applied successfully for decades, this safety device responds mechanically to the internal rise of pressure that is usually associated with the failure of polypropylene capacitors. However, Mesis® manages without an external expansion of the housing. For the first time, capacitors can be installed firmly and connected to rigid, low-inductance bus bars without impairing the function of the fuse.

The signal of the overpressure protection can be used either on site or at a central detection system for the immediate disconnection of the circuit of one or more affected capacitors. There are many options with regard to interconnection (individually or in groups) and monitoring (with common control voltages up to 230 Vrms or 24V DC), so that almost all issues are taken into account.

This unique combination of the lowest self-inductance, shielding against environmental influences and reliable protection in the event of malfunctions, in connection with the well-known long-term stability of our SecuMet metallization, makes GA85 E67 Mesis® the ideal capacitor for safety and life-time sensitive applications, such as railway, marine and offshore installations.

Minimale Induktivität und zuverlässige Sicherung: E67 GA85 Mesis®

Unerwünschte Streuinduktivitäten können in Hochstromzwischenkreisen sehr deutliche Spannungsüberschwingungen verursachen (sogen. voltage overshooting). Dadurch sind beträchtliche Schäden möglich.

Dem begegnet man zum einen durch die Perfektionierung der Verschaltung (Sandwich-Sammelschienen, welche die eigene Induktivität zu großen Teilen neutralisieren); zum anderen spielt aber auch die Eigeninduktivität des Kondensators eine sehr bedeutsame Rolle. In Zwischenkreisen mit hohen Schaltfrequenzen oder solchen mit großem Kapazitätsbedarf ist diese Herausforderung umso größer. Die klassische Lösung – sehr flache Kondensatoren möglichst nahe an der Sammelschiene – kommt platz- und kostenbedingt nur begrenzt zum Tragen.

Die Zwischenkreiskondensatoren unserer neuen Baureihe GA85 E67 tragen diesem Problem durch eine besonders niedrige Eigeninduktivität und verlustarmen Aufbau Rechnung. Die Ausführung mit zwei Anschlüssen erzielt selbst bei großen Kapazitäten in Gehäusehöhen von 280mm Eigeninduktivitäten unter 55 nH; mit vier kreuzweise angeordneten Terminals können in kürzeren Bechern sogar 10 nH erreicht werden. In Kombination mehrerer Einheiten lassen sich damit bisher ungekannte Werte erzeugen.

Die Kondensatoren sind durch metallische Becher und Deckel dicht verschlossen und somit hervorragend gegen Umgebungseinflüsse wie Feuchtigkeit oder Verunreinigungen durch Schadstoffe abgeschirmt. So ist eine zeitweilige Batauung dieser Kondensatoren ebenso zulässig wie IEC-Feuchteprüfungen unter Extrembedingungen mit 85%RH bei 85°C.

Als weltweit erste Kondensatoren verfügen die E67er über unsere innovative Mesis® Überdrucksicherung. Genau wie unsere jahrzehntelang bewährten BAM-Sicherungen reagiert diese Sicherung mechanisch auf den inneren Druckanstieg, welcher in aller Regel mit dem Ausfall von Folienkondensatoren einhergeht. Mesis® kommt hierbei jedoch ohne äußerliche Verlängerung des Gehäuses aus. Erstmals lassen sich nun fest installierte gesicherte Kondensatoren mit starren, niederinduktiven Sammelschienen verschalten, ohne dabei die Funktion der Sicherung zu beeinträchtigen. Das Signal der Überdrucksicherung kann entweder vor Ort, oder an einer zentralen Erfassung für die sofortige Abschaltung des Zwischenkreises eines oder mehrerer betroffener Kondensatoren verwendet werden. Bezüglich Verschaltung (einzeln oder in Gruppen) und Auswertung (übliche Steuerspannungen von bis zu 230 Vrms oder 24 VDC) gibt es viele Freiheitsgrade, so dass nahezu alle Belange berücksichtigt sind.

Diese einzigartige Kombination von niedrigster Eigeninduktivität, Abschirmung vor Umwelteinflüssen und zuverlässigem Schutz im Falle von Fehlfunktionen, in Verbindung mit der bekannten Langzeitstabilität unserer SecuMet-Metallisierung macht GA85 E67 Mesis® zum idealen Kondensator für sicherheits- und lebensdauersensible Einsatzfälle, wie z.B. Bahn-, Marine- und Offshore-Anwendungen.



for latest edition and updates
check www.powercapacitors.info

E67.***GA85 Mesis®
DC
700...950V

**Low-inductance DC capacitors in sealed housing,
Mesis® Overpressure Switch**
**Niederinduktive Zwischenkreiskondensatoren in dichtem
Gehäuse, Mesis® Überdruckschalter**

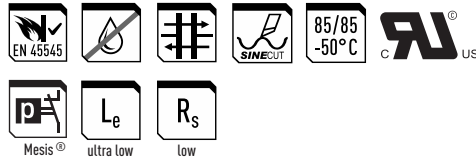

Standards IEC 61881/61071, UL 810B,
EN 45545-2 (ext. plastic material äußere Kunststoffe HL3),
EN45545-3 (integrity Integrität E30)
can Gehäuse aluminium
mounting position optional
Einbautage beliebig
filling material neutral insulation gas (N₂)
Füllmittel neutrales Isoliergas (N₂)
protection Mesis® pressure switch
Sicherung Mesis® Überdruckschalter
fire load Brandlast 40 MJ/kg

C_N tolerance Toleranz ±10%; optional ±5%
tanδ₀ 2 × 10⁻⁴
limit temperatures Grenztemperaturen
θ_{min} -50°C
θ_{max} HOTSPOT +85°C¹
storing temperature Lagertemperatur -50°C ... +85°C
Life time Lebensdauer > 200 000 h
Failure rate Ausfallrate 100 FIT²

¹ endurance type test_Lebensdauertest: @ 80°C
² reference service life_Referenzbetriebsdauer 100.000 h, θ_{HotSpot} <70°C

		Design W4					Design W6						
C _N (µF)	R _{th} (K/W)	R _s (mΩ)	I _{max} (A)	Î (kA)	L _e (nH)	R _s (mΩ)	I _{max} (A)	Î (kA)	L _e (nH)	D ₁ × L ₁ (mm)	m (kg)	order no. Bestell-Nr.	
U_N 700V DC		U_r 200V		U_s 1050V		U_{TT} 1050V DC		U_{Tc} 3300V AC/2s					
515	7.3	0.3	65	6.4	10	0.45	60	6.4	25	116 × 83	0.9	E67.R83-524W4/W60	
1030	4.8	0.25	90	12.8	10	0.4	80	12.8	25	116 × 126	1.3	E67.R12-105W4/W60	
1350	4.5	0.53	65	6.4	16	0.7	60	6.4	40	116 × 133	1.4	E67.R13-145W4/W60	
1545	3.6	0.25	120	19.2	15	0.4	100	19.2	35	116 × 169	1.6	E67.R16-155W4/W60	
2700	2.7	0.46	90	12.8	20	0.6	90	12.8	45	116 × 225	2.2	E67.R22-275W4/W60	
4050	1.9	0.45	120	19.2	25	0.63	120	19.2	55	116 × 319	3.2	E67.R31-415W4/W60	
U_N 800V DC		U_r 200V		U_s 1200V		U_{TT} 1200V DC		U_{Tc} 3300V AC/2s					
385	7.3	0.3	65	5.6	10	0.43	60	5.6	25	116 × 83	0.9	E67.R83-394W4/W60	
770	4.8	0.26	90	11.2	10	0.4	80	11.2	25	116 × 126	1.3	E67.R12-774W4/W60	
1025	4.5	0.58	65	5.7	16	0.75	60	5.7	40	116 × 133	1.4	E67.R13-105W4/W60	
1155	3.6	0.27	120	16.8	15	0.41	100	16.8	35	116 × 169	1.6	E67.R16-125W4/W60	
2050	2.7	0.46	90	11.4	20	0.66	90	11.4	45	116 × 225	2.2	E67.R22-215W4/W60	
3075	1.9	0.45	120	17.1	25	0.64	120	17.1	55	116 × 319	3.2	E67.R31-315W4/W60	
U_N 950V DC		U_r 200V		U_s 1425V		U_{TT} 1425V DC		U_{Tc} 3480V AC/2s					
325	7.3	0.32	65	5.1	10	0.45	60	5.1	25	116 × 83	0.9	E67.R83-334W4/W60	
650	4.8	0.27	90	10.2	10	0.4	80	10.2	25	116 × 126	1.3	E67.R12-654W4/W60	
865	4.5	0.62	65	5.2	16	0.79	60	5.2	40	116 × 133	1.4	E67.R13-874W4/W60	
975	3.6	0.27	120	15.3	15	0.41	100	15.3	35	116 × 169	1.6	E67.R16-984W4/W60	
1730	2.7	0.48	90	10.4	20	0.64	90	10.4	45	116 × 225	2.2	E67.R22-175W4/W60	
2595	1.9	0.46	120	15.6	25	0.66	120	15.6	55	116 × 319	3.2	E67.R31-265W4/W60	



For details of design W4 and W6 see page 38.
Für Details zu den Ausführungen W4 und W6 siehe S.38.

Other values and dimensions available on request.
Andere Werte und Abmessungen auf Anfrage erhältlich.



E67.***GA85 Mesis®
DC
1000...1625V



C _N (μF)	R _{th} (K/W)	Design W4				Design W6				D ₁ × L ₁ (mm)	m (kg)	order no. Bestell-Nr.
		R _s (mΩ)	I _{max} (A)	Î (kA)	L _e (nH)	R _s (mΩ)	I _{max} (A)	Î (kA)	L _e (nH)			
U_N 1000V DC		U_r 200V		U_s 1500V		U_{TT} 1500V DC		U_{Tc} 3600V AC/2s				
300	7.3	0.32	65	5	10	0.46	60	5	25	116 × 83	0.9	E67.R83-304W4/W60
600	4.8	0.27	90	10	10	0.4	80	10	25	116 × 126	1.3	E67.R12-604W4/W60
780	4.5	0.64	65	4.9	16	0.81	60	4.9	40	116 × 133	1.4	E67.R13-784W4/W60
900	3.6	0.27	120	15	15	0.42	100	15	35	116 × 169	1.6	E67.R16-904W4/W60
1560	2.7	0.49	90	9.8	20	0.65	90	9.8	45	116 × 225	2.2	E67.R22-165W4/W60
2340	1.9	0.47	120	14.7	25	0.66	120	14.7	55	116 × 319	3.2	E67.R31-235W4/W60
U_N 1100V DC		U_r 250V		U_s 1650V		U_{TT} 1650V DC		U_{Tc} 3840V AC/2s				
235	7.3	0.35	65	4.4	10	0.48	60	4.4	25	116 × 83	0.9	E67.R83-244W4/W60
470	4.8	0.29	90	8.8	10	0.41	80	8.8	25	116 × 126	1.3	E67.R12-474W4/W60
615	4.5	0.7	65	4.4	16	0.87	60	4.4	40	116 × 133	1.4	E67.R13-624W4/W60
705	3.6	0.28	120	13.2	15	0.43	100	13.2	35	116 × 169	1.6	E67.R16-714W4/W60
1230	2.7	0.52	90	8.8	20	0.68	90	8.8	45	116 × 225	2.2	E67.R22-125W4/W60
1845	1.9	0.49	120	13.2	25	0.68	120	13.2	55	116 × 319	3.2	E67.R31-185W4/W60
U_N 1300V DC		U_r 300V		U_s 1950V		U_{TT} 1950V DC		U_{Tc} 4320V AC/2s				
175	7.3	0.39	65	3.8	10	0.52	60	3.8	25	116 × 83	0.9	E67.R83-184W4/W60
350	4.8	0.3	90	7.6	10	0.43	80	7.6	25	116 × 126	1.3	E67.R12-354W4/W60
465	4.5	0.78	65	3.8	16	0.95	60	3.8	40	116 × 133	1.4	E67.R13-474W4/W60
525	3.6	0.29	120	11.4	15	0.44	100	11.4	35	116 × 169	1.6	E67.R16-534W4/W60
930	2.7	0.56	90	7.6	20	0.72	90	7.6	45	116 × 225	2.2	E67.R22-934W4/W60
1395	1.9	0.52	120	11.4	25	0.71	120	11.4	55	116 × 319	3.2	E67.R31-145W4/W60
U_N 1500V DC		U_r 300V		U_s 2250V		U_{TT} 2250V DC		U_{Tc} 4800V AC/2s				
125	7.3	0.46	65	3.2	10	0.6	60	3.2	25	116 × 83	0.9	E67.R83-134W4/W60
250	4.8	0.34	90	6.4	10	0.46	80	6.4	25	116 × 126	1.3	E67.R12-254W4/W60
330	4.5	0.9	65	3.2	16	1.1	60	3.2	40	116 × 133	1.4	E67.R13-334W4/W60
375	3.6	0.32	110	9.6	15	0.46	100	9.6	35	116 × 169	1.6	E67.R16-384W4/W60
660	2.7	0.65	90	6.4	20	0.82	90	6.4	45	116 × 225	2.2	E67.R22-664W4/W60
990	1.9	0.55	120	9.6	25	0.76	120	9.6	55	116 × 319	3.2	E67.R31-994W4/W60
U_N 1625V DC		U_r 300V		U_s 2440V		U_{TT} 2440V DC		U_{Tc} 5200V AC/2s				
110	7.3	0.45	65	3	10	0.59	60	3	25	116 × 83	0.9	E67.R83-114W4/W60
220	4.8	0.34	90	6	10	0.46	80	6	25	116 × 126	1.3	E67.R12-224W4/W60
280	4.5	0.98	65	2.9	16	1.1	60	2.9	40	116 × 133	1.4	E67.R13-284W4/W60
330	3.6	0.32	110	9	15	0.46	100	9	35	116 × 169	1.6	E67.R16-334W4/W60
560	2.7	0.66	90	5.8	20	0.82	90	5.8	45	116 × 225	2.2	E67.R22-564W4/W60
840	1.9	0.58	120	8.7	25	0.78	120	8.7	55	116 × 319	3.2	E67.R31-844W4/W60

DATA CHARTS_DATENTABELLEN_E67.*** GA85 Mesis®

Other values and dimensions available on request.
Andere Werte und Abmessungen auf Anfrage erhältlich.

For details of design W4 and W6 see page 38.
Für Details zu den Ausführungen W4 und W6 siehe S.38.



C _N (µF)	R _{th} (K/W)	Design W4				Design W6				D ₁ × L ₁ (mm)	m (kg)	order no. Bestell-Nr.
		R _s (mΩ)	I _{max} (A)	Î (kA)	L _e (nH)	R _s (mΩ)	I _{max} (A)	Î (kA)	L _e (nH)			
U_N 1800V DC		U_f 400V		U_s 2700V		U_{TT} 2700V DC		U_{Tc} 5520V AC/2s				
91	7.3	0.47	65	2.8	10	0.6	60	2.8	25	116 × 83	0.9	E67.R83-913W4/W60
182	4.8	0.35	90	5.6	10	0.47	80	5.6	25	116 × 126	1.3	E67.R12-184W4/W60
235	4.5	1	65	2.8	16	1.2	60	2.8	40	116 × 133	1.3	E67.R13-244W4/W60
273	3.6	0.32	110	8.4	15	0.46	100	8.4	35	116 × 169	1.6	E67.R16-274W4/W60
470	2.7	0.67	90	5.6	20	0.83	90	5.6	45	116 × 225	2.2	E67.R22-474W4/W60
705	1.9	0.59	120	8.4	25	0.79	120	8.4	55	116 × 319	3.2	E67.R31-714W4/W60
U_N 2000V DC		U_f 550V		U_s 3000V		U_{TT} 3000V DC		U_{Tc} 6000V AC/2s				
70	7.3	0.54	60	2.3	10	0.67	55	2.3	25	116 × 83	0.9	E67.R83-703W4/W60
140	4.8	0.36	90	4.6	10	0.51	80	4.6	25	116 × 126	1.3	E67.R12-144W4/W60
190	4.5	1.1	60	2.4	16	1.3	55	2.4	40	116 × 133	1.4	E67.R13-194W4/W60
210	3.6	0.33	110	6.9	15	0.48	100	6.9	35	116 × 169	1.6	E67.R16-214W4/W60
380	2.7	0.72	90	4.8	20	0.89	90	4.8	45	116 × 225	2.2	E67.R22-384W4/W60
570	1.9	0.63	120	7.2	25	0.82	120	7.2	55	116 × 319	3.2	E67.R31-574W4/W60
U_N 2200V DC		U_f 600V		U_s 3300V		U_{TT} 3300V DC		U_{Tc} 6480V AC/2s				
60	7.3	0.57	55	2.2	10	0.7	50	2.2	25	116 × 83	0.9	E67.R83-603W4/W60
120	4.8	0.4	80	4.4	10	0.52	80	4.4	25	116 × 126	1.3	E67.R12-124W4/W60
165	4.5	1.2	55	2.3	16	1.4	50	2.3	40	116 × 133	1.4	E67.R13-174W4/W60
180	3.6	0.36	110	6.6	15	0.5	100	6.6	35	116 × 169	1.6	E67.R16-184W4/W60
330	2.7	0.76	90	4.6	20	0.92	80	4.6	45	116 × 225	2.2	E67.R22-334W4/W60
495	1.9	0.65	120	6.9	25	0.85	100	6.9	55	116 × 319	3.2	E67.R31-504W4/W60
U_N 2450V DC		U_f 600V		U_s 3675V		U_{TT} 3675V DC		U_{Tc} 7500V AC/2s				
46	7.3	0.64	55	1.9	10	0.78	50	1.9	25	116 × 83	0.9	E67.R83-463W4/W60
92	4.8	0.43	80	3.8	10	0.56	80	3.8	25	116 × 126	1.3	E67.R12-923W4/W60
125	4.5	1.4	50	1.9	16	1.5	50	1.9	40	116 × 133	1.4	E67.R13-134W4/W60
138	3.6	0.38	110	5.7	15	0.52	100	5.7	35	116 × 169	1.6	E67.R16-144W4/W60
250	2.7	0.85	90	3.8	20	1	80	3.8	45	116 × 225	2.2	E67.R22-254W4/W60
375	1.9	0.72	110	5.7	25	0.91	100	5.7	55	116 × 319	3.2	E67.R31-384W4/W60
U_N 2900V DC		U_f 600V		U_s 4350V		U_{TT} 4350V DC		U_{Tc} 7500V AC/2s				
210	1.9	-	-	-	-	0.55	80	8.2	55	116 × 319	3.2	E67.R31-214W60
U_N 4000V DC		U_f 800V		U_s 6000V		U_{TT} 6000V DC		U_{Tc} 7500V AC/2s				
63	2.7	-	-	-	-	1.7	60	3.4	50	116 × 225	2.2	E67.R22-633W60
95	1.9	-	-	-	-	1.3	80	5.1	65	116 × 319	3.2	E67.R31-953W60



FOR

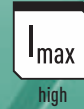
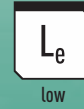

PK16™ – THE INDUSTRIAL STANDARD: LOW INDUCTANCE AND HIGH CAPACITANCE DENSITY

DER INDUSTRIESTANDARD: NIEDRIGE INDUKTIVITÄT UND HOHE KAPAZITÄTSDICHTE



ELECTRONICON
PK 16™ E50.529-344N10
340 µF ±10%
U_N 2600 V DC
IEC 610/1 dry (PUR)
-40...+75°C ±±
no internal protection
terminal torque max. 4Nm
RU UL No. 810
-40...+75°C
Made in Germany



ELECTRONICON
PK 16™ E50.529-344N10
340 µF ±10%
U_N 2600 V DC
IEC 610/1 dry (PUR)
-40...+75°C ±±
no internal protection
terminal torque max. 4Nm
RU UL No. 810
-40...+75°C
Made in Germany



ELECTRONICON
PK 16™ E50.529-344N10
340 µF ±10%
U_N 2600 V DC
IEC 610/1 dry (PUR)
-40...+75°C ±±
no internal protection
terminal torque max. 4Nm
RU UL No. 810
-40...+75°C
Made in Germany



PK16™ – ideal for your high-current DC-circuit

The PK16™ capacitor can be universally used for the assembly of low inductance DC buffer circuits and DC filters; with its high energy density it can replace banks of series-connected electrolytic capacitors as well as large film capacitors in rectangular cases.

The capacitance in a DC buffer circuit must be sufficiently sized to both handle the current and smoothen the occurring ripple voltages. The traditional use of series-/parallel-connected electrolytic capacitors offered large capacitance at seemingly low cost, however the low cost per microfarad is countered by the low current strength, the high sensitivity to voltage and current surges, as well as high risk of failures in the field, resulting in high maintenance cost.

Our advanced know-how in special capacitor film coating and many years of practical experience in designing and manufacturing capacitors have allowed us to design our PK16™ range with high capacitance density. With fivefold the current strength of conventional electrolytic capacitors, it is not necessary to reproduce the same capacitance in film technology in order to handle a given current.

Instead, the user now gets a superior technical solution within the same – or even less – space, offering

- superior voltage and current strength
- dramatic increase in operational life
- drastic reduction of failures
- minimization of power dissipation losses
- substantial reduction of self-inductance and series resistance
- more exact manufacturing tolerances
- elimination of sharing resistors

Thanks to its compact cylindrical aluminium can design this capacitor is ideal for both the electrical and mechanical requirements of high-speed IGBT converters.

Its robust terminals and the robust fixing stud allow for very simple and reliable mounting that unites lowest inductance and highest current strength. The particularly large clearance and creepage distances make this design suitable for a wide range of operating voltages. As a result, existing standard converter concepts can easily be adapted to new applications without having to change the principal construction and to re-approve the entire system.

PK16™ – Ideal für die hohen Ströme Ihres Zwischenkreises

Der PK16™ Kondensator lässt sich universell zum Aufbau niederinduktiver DC Zwischenkreise und für DC Filter einsetzen und kann mit seiner hohen Energiedichte sowohl Batterien seriengeschalteter Elektrolytkondensatoren als auch große quaderförmige Folienkondensatoren ersetzen.

Die Kapazität in einem DC-Zwischenkreis muß groß genug sein, um auftretende überlagerte Wechselspannungen zu glätten und entsprechende Rippleströme zu bewältigen. Die traditionelle Serien-/Parallelschaltung von Elektrolytkondensatoren bietet hohe Kapazität zu scheinbar niedrigen Kosten, jedoch steht den geringen Kosten je Mikrofarad eine niedrige Strombelastbarkeit, hohe Stoßstrom- und Spannungsempfindlichkeit sowie ein erhebliches Ausfallrisiko im Feld gegenüber, welches sich in hohen Wartungskosten niederschlägt.

Unser hochentwickeltes Know-How in der Metallisierung von Kondensatorfolien und langjährige praktische Erfahrungen in der Entwicklung und Herstellung von Kondensatoren ermöglichten uns die Schaffung unserer PK16™ Serie mit hoher Kapazitätsdichte. Dank fünffacher Stromfestigkeit gegenüber üblichen Elektrolytkondensatoren ist es nicht mehr notwendig, exakt die gleiche Kapazität in Folientechnologie zu erreichen, um einen gegebenen Strom zu bewältigen.

Statt dessen erhält der Anwender eine hochwertige technische Lösung mit gleichem oder vermindertem Platzbedarf und folgenden Vorteilen:

- höhere Spannungs- und Stromfestigkeit
- drastische Verlängerung der Lebensdauer
- bemerkenswerte Reduzierung von Ausfällen
- Minimierung der Verlustleistung
- erhebliche Verringerung der Eigeninduktivität und des Serienwiderstandes
- genauere Produktionstoleranzen
- Eliminierung von Symmetrierwiderständen

Mit seiner kompakten zylindrischen Bauform in Aluminiumgehäuse ist der Kondensator optimal an elektrische und mechanische Erfordernisse in schnelltaktenden IGBT Stromrichtern angepasst.

Die robusten Anschlusselemente und eine stabile Bodenbefestigung ermöglichen eine besonders einfache Montage, die niedrigste Induktivität und hohe Strombelastbarkeit miteinander vereinigt. Die außerordentlich großen Luft- und Kriechstrecken decken einen weiten Spannungsbereich ab, ohne dass dadurch die Bauform gewechselt werden müsste. Damit kann ein Standard-Stromrichterkonzept sehr viel flexibler auf unterschiedliche Anwendungen ausgerichtet werden, ohne neue Konstruktionen und damit neue Systemprüfungen erforderlich zu machen.

Important notice

Our MKP capacitors of the PK16™ series are made with self-healing dielectric. In the event of voltage breakdowns, caused by weak spots in the dielectric or high thermal/electrical load, the metal coating around the breakdown spot is vaporized within a few microseconds. As a result, the area around the breakdown spot is de-metalized, and the capacitor remains fully functional.

The release of energy during a regular self-healing breakdown, and the amount of gas generated in the process, are so small that even after thousands of such self-healing procedures there is no significant build-up of overpressure inside the capacitor.

The scenario of self-healing breakdown becomes less likely, or impossible, under high thermal or electrical overstress. The disintegration of the polypropylene dielectric may produce more or less amounts of gas accompanied by a build-up of internal pressure. Very frequent and large-scale occurrence of self-healing breakdowns (e.g., as a result of strong voltage overstrain) may cause a gradual rise of the internal pressure as well.

For the sake of lowest available self-inductance and maximum mounting comfort, the capacitors of our PK16™ range are not equipped with an integrated safety mechanism to disconnect them in the event of overload or failure. They should therefore not be operated beyond their rated values and be allocated in uncritical environment (non-inflammable materials) where build-up of pressure or even ignition of the polypropylene cannot cause consequential damage.

Wichtiger Hinweis

Alle in unseren PK16™-Kondensatoren verwendeten dielektrischen Strukturen sind selbstheilend. Im Falle eines Kurzschlusses (z. B. Spannungsdurchschlag an Schwachstellen im Dielektrikum, oder infolge starker thermischer/elektrischer Belastung) verdampfen binnen weniger Mikrosekunden die Metallbeläge rings um den Durchschlagspunkt und bilden eine belagfreie, isolierende Zone. Dabei bleibt der Kondensator voll funktionsfähig.

Die freigesetzte Energie während eines selbstheilenden Durchschlages und die dabei erzeugte Menge an Gas sind so gering, dass selbst nach tausenden solcher Selbstheilungsvorgänge kein nennenswerter Überdruck im Kondensatorinneren entsteht.

Der zuverlässige Ablauf selbstheilender Durchschläge kann jedoch durch hohe thermische oder elektrische Belastung beeinträchtigt oder verhindert werden. Sich zersetzendes Polypropylen erzeugt dann größere Mengen an Gas und der Innendruck im Kondensator steigt. Gleichermaßen können auch häufig und großflächig auftretende Durchschläge (z.B. infolge starker Überspannung) einen starken Anstieg des Innendrucks verursachen.

Zum Zwecke niedrigster Eigeninduktivität und maximalen Einbaukomforts verfügen die Kondensatoren unserer PK16™ Reihe nicht über einen internen Abschaltmechanismus für Fehlerfälle oder spannungsmäßige Überlastung. Sie sollten daher nicht außerhalb ihrer zulässigen Nennwerte betrieben und stets in unkritischer Umgebung (nichtentflammbare Materialien) platziert werden, wo Gasfreisetzung bzw. ein Entzünden des Dielektrikums keine schwerwiegenden Folgeschäden verursachen können.



E50.***PK16™
DC
600V

for latest edition and updates
check www.powercapacitors.info



Low-inductance DC Capacitors
Niederinduktive Zwischenkreiskondensatoren

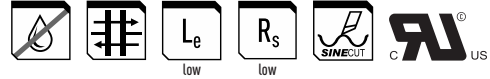

Standards..... IEC 61071, optional IEC 61881
UL 810
can Gehäuse..... aluminium/plastic, (UL94: V0)
mounting position..... optional
Einbaulage..... beliebig
filling material..... solid, based on vegetable oil, non-PCB
Füllmittel..... ausgehärtet, auf Pflanzenölbasis, PCB-frei
internal protection..... none
interne Sicherung..... keine
fire load Brandlast..... 40 MJ/kg

C_N tolerance Toleranz..... ±10%; optional ±5%
tanδ₀..... 2 × 10⁻⁴
limit temperatures Grenztemperaturen
θ_{min}..... -40°C
θ_{max} (HOTSPOT)..... +85°C¹
storing temperature Lagertemperatur..... -40°C ... +85°C
Life time Lebensdauer..... > 200 000 h
Failure rate Ausfallrate..... 50 FIT²

¹endurance type test_Lebensdauertest: 0116 @80°C, 0136 @75°C
²reference service life_Referenzbetriebsdauer 100000 h, θ_{HOTSPOT} <70°C

C _N (µF)	R _s (mΩ)	R _{th} (K/W)	I _{max} (A)	Î (kA)	I _s (kA)	E _N (Ws)	L _e (nH)	D ₁ × L ₁ (mm)	Design Maßbild	m (kg)	order no. Bestell-Nr.	pcs / Box Stk / Box
U _N 600V DC		U _r 100V	U _s 900V	U _{TT} 900V DC	U _{TC} 3300V AC/2s							
465	2.6	5.8	20	1.9	5.7	84	50	67 × 114	N4	0.4	E50.L11-474N40	10/FB2
555	1	6.7	40	3.8	11.4	100	30	85 × 85	NT	0.5	E50.N85-564NTO	10/FB12
680	1.1	6	40	3.8	11.5	122	40	85 × 95	NT	0.6	E50.N95-684NTO	10/FB12
780	1.6	5.2	30	3.7	11	140	60	85 × 110	NT	0.7	E50.N11-784NTO	10/FB10
930	1.4	4.7	40	3.8	11.5	167	35	85 × 120	NT	0.7	E50.N12-934NTO	10/FB10
1000	1.8	4.2	35	3.7	11	180	55	85 × 136	NT	0.8	E50.N13-105NTO	10/FB15
1110	0.84	3.8	80	7.6	22.9	200	40	85 × 150	NT	0.9	E50.N15-115NT1	5/FB8
1430	2.3	3.1	35	3.7	11.1	257	60	85 × 181	NT	1.2	E50.N18-145NTO	5/FB8
1450	0.82	3.1	80	10	29.9	261	45	100 × 155	N5	1.3	E50.Q15-155N57	3/FB8
2000	1.4	2.3	60	7.4	22	360	60	85 × 252	NT	1.6	E50.N25-205NTO	5/FB10
2070	0.62	2.5	90	14.2	42.7	373	40	116 × 155	NT	1.8	E50.R15-215NTO	3/FB8
2530	0.66	2.1	90	14.2	42.6	455	50	116 × 180	NT	2.1	E50.R18-255NTO	3/FB12
4000	0.58	1.3	120	20	60	720	70	116 × 295	NT	3.2	E50.R29-405NTO	3/FB15
4275	0.55	1.5	120	29	88	770	60	136 × 220	NT	3.4	E50.S22-435NTO	2/FB12
5060	0.72	1.1	120	28.4	85.2	911	85	116 × 340	NT	3.9	E50.R34-515NTO	3/FB15
7000	0.66	1	120	29	87	1260	70	136 × 335	NT	5.2	E50.S33-705NTO	2/FB15



C_N (μ F)	R_s (m Ω)	R_{th} (K/W)	I_{max} (A)	\hat{I} (kA)	I_s (kA)	E_N (Ws)	L_e (nH)	$D_1 \times L_1$ (mm)	Design Maßbild	m (kg)	order no. Bestell-Nr.	pcs / Box Stk / Box
U_N 700V DC		U_r 200V		U_s 1050V		U_{TT} 1050V DC		U_{TC} 3300V AC/2s				
410	1.1	6.7	40	3.3	9.9	100	30	85 × 85	NT	0.5	E50.N85-414NT0	10/FB12
585	1.7	5.2	30	3.2	9.6	143	60	85 × 110	NT	0.7	E50.N11-594NT0	10/FB10
650	1.2	4.4	40	3.6	10.8	159	50	100 × 110	N57	0.9	E50.Q11-654N57	6/FB15
820	0.87	3.8	80	6.6	19.7	201	40	85 × 150	NT	1	E50.N15-824NT0	5/FB8
1170	1.3	2.7	60	6.5	19.5	287	60	85 × 210	NT	1.25	E50.N21-125NT0	5/FB12
1530	0.64	2.5	90	12.3	36.8	375	45	116 × 155	NT	1.8	E50.R15-155NT0	3/FB8
1500	1.5	2.3	60	6.4	19	367	60	85 × 252	NT	1.6	E50.N25-155NT0	5/FB10
2120	0.69	1.8	60	11.7	35.1	519	50	116 × 215	NT	2.4	E50.R21-215NT0	3/FB12
2295	0.62	1.7	120	18.4	55.2	562	60	116 × 220	NT	2.5	E50.R22-235NT0	3/FB12
2920	0.59	1.3	100	23.4	70	715	70	116 × 295	NT	3.2	E50.R29-295NT0	3/FB15
3200	0.55	1.5	120	25	75	784	60	136 × 220	NT	3.4	E50.S22-325NT0	2/FB12
5200	0.68	1	120	25	75	1274	70	136 × 335	NT	5.2	E50.S33-525NT0	2/FB15
U_N 900V DC		U_r 200V		U_s 1350V		U_{TT} 1350V DC		U_{TC} 3360V AC/2s				
220	1	7.3	35	2.6	7.8	89	40	85 × 78	NT	0.5	E50.N78-224NT0	10/FB10
300	3.7	5.8	20	1.5	5	122	50	67 × 114	N4	0.4	E50.L11-304N40	10/FB2
340	0.85	5.2	60	5.6	16.8	138	60	85 × 110	NT	0.7	E50.N11-344NT0	10/FB10
350	1.1	6.7	40	3.0	9	142	30	85 × 85	NT	0.5	E50.N85-354NT0	10/FB12
450	1.8	5.2	30	2.8	8.4	182	60	85 × 110	NT	0.7	E50.N11-454NT0	10/FB10
590	0.81	4.2	80	6.1	18.3	239	40	85 × 136	NT	0.8	E50.N13-594NT0	5/FB8
610	1.1	3.7	60	5.6	16.8	247	40	85 × 155	NT	1	E50.N15-614NT0	5/FB8
700	0.89	3.8	80	6.1	18.3	284	30	85 × 150	NT	1	E50.N15-704NT0	5/FB8
1060	1.3	2.5	75	5.8	17.4	429	60	85 × 225	NT	1.35	E50.N22-115NT0	5/FB12
1095	0.94	3.1	65	5.7	17.1	443	35	116 × 125	NT	1.4	E50.R12-115NT0	6/FB10
1150	1.6	2.3	60	5.7	17.1	466	60	85 × 252	NT	1.6	E50.N25-125NT0	5/FB10
1170	0.66	2.5	100	10.7	32.1	474	40	116 × 155	NT	1.75	E50.R15-125NT0	3/FB8
1310	0.65	2.5	90	11.4	34.2	531	45	116 × 155	NT	1.75	E50.R15-135NT1	3/FB8
1740	1.2	2.1	65	5.7	17.1	705	50	116 × 180	NT	2.1	E50.R18-175NT0	3/FB8
2620	0.71	1.3	120	22.8	68.4	1061	75	116 × 290	NT	3.3	E50.R29-265NT0	3/FB15
2700	0.56	1.5	120	23.5	70.5	1094	60	136 × 220	NT	3.4	E50.S22-275NT0	2/FB12
3380	0.8	1.2	60	14.6	43.8	1368	70	136 × 280	NT	4.3	E50.S28-345NT0	2/FB10
4590	0.78	1	120	23.9	71.7	1859	85	136 × 335	NT	5.2	E50.S33-465NT0	2/FB15



E50.***PK16™

DC

1100...1200V



C_N (μF)	R_s ($m\Omega$)	R_{th} (K/W)	I_{max} (A)	\hat{I} (kA)	I_s (kA)	E_N (Ws)	L_e (nH)	$D_1 \times L_1$ (mm)	Design Maßbild	m (kg)	order no. Bestell-Nr.	pcs / Box Stk / Box
U_N 1100V DC			U_r 250V	U_s 1650V	U_{TT} 1650V DC			U_{TC} 3840V AC/2s				
200	3.5	5.8	30	1.5	5	121	50	67 × 114	N4	0.4	E50.L11-204N40	10/FB2
280	1.4	6	40	2.5	7.4	169	30	85 × 95	NT	0.6	E50.N95-284NT0	10/FB12
375	0.67	3.9	90	7.3	21.9	227	40	85 × 146	NT	0.9	E50.N14-384NT0	5/FB8
380	1.8	4.7	40	2.4	7.3	230	35	85 × 120	NT	0.7	E50.N12-384NT0	10/FB10
420	1.9	4.4	40	2.4	7.3	254	40	85 × 130	NT	0.8	E50.N13-424NT1	5/FB8
450	0.86	3.8	80	4.8	14.4	272	40	85 × 150	NT	1	E50.N15-454NT1	5/FB8
580	0.88	3.1	80	6.2	18.7	351	45	100 × 155	N5	1.3	E50.Q15-584N57	3/FB8
595	2.8	3.1	40	2.4	14.8	360	60	85 × 181	NT	1.2	E50.N18-604NT0	5/FB8
800	0.85	2.6	80	9	27	484	40	116 × 145	NT	0.97	E50.R14-804NT0	3/FB8
830	1.7	2.3	60	4.8	14.4	502	60	85 × 252	NT	1.6	E50.N25-834NT0	5/FB10
990	1.2	2.1	80	6.4	19.1	599	60	100 × 230	N5	1.9	E50.Q23-994N57	3/FB12
1100	1.4	2.1	65	4.5	13.5	666	40	116 × 180	NT	2.1	E50.R18-115NT0	3/FB12
1245	0.65	1.7	120	13.4	40.2	753	60	116 × 220	NT	2.5	E50.R22-125NT0	3/FB12
1660	0.71	1.3	120	17.9	53.6	1004	75	116 × 290	NT	3.2	E50.R29-175NT1	3/FB15
1750	1	1.4	95	8.9	26.7	1059	70	116 × 280	NT	3.2	E50.R28-185NT0	3/FB10
1850	0.57	1.5	120	20	60	1119	60	136 × 220	NT	3.4	E50.S22-195NT0	2/FB12
2200	1.1	1.1	90	9	27.1	1331	70	116 × 340	NT	3.5	E50.R34-225NT1	3/FB15
2500	0.86	1.2	60	12.7	38.1	1512	70	136 × 280	NT	4.3	E50.S28-255NT0	2/FB10
3100	0.79	1	120	20	60	1875	85	136 × 335	NT	5.2	E50.S34-315NT0	2/FB15
U_N 1200V DC			U_r 250V	U_s 1800V	U_{TT} 1800V DC			U_{TC} 4080V AC/2s				
370	0.99	3.8	75	4.4	13.2	266	40	85 × 150	NT	0.9	E50.N15-374NT0	5/FB8
500	0.52	2.7	80	7.7	23.1	360	40	116 × 140	NT	1.6	E50.R14-504NT0	6/FB15
1035	0.69	1.7	120	12.3	37	745	60	116 × 220	NT	2.5	E50.R22-105NT0	3/FB12
1450	0.63	1.5	120	17.3	51.9	1044	60	136 × 220	NT	3.4	E50.S22-155NT0	2/FB12
2450	0.81	1	120	17.5	52.5	1764	85	136 × 335	NT	5.2	E50.S33-255NT0	2/FB15



E50.***PK16™
DC
1300...1800V

C _N (μF)	R _s (mΩ)	R _{th} (K/W)	I _{max} (A)	Î (kA)	I _s (kA)	E _N (Ws)	L _e (nH)	D ₁ × L ₁ (mm)	Design Maßbild	m (kg)	order no. Bestell-Nr.	pcs / Box Stk / Box
U_N 1300V DC		U_r 300V		U_s 1950V		U_{TT} 1950V DC		U_{Tc} 4320V AC/2s				
145	1.4	6.7	40	1.9	5.8	123	40	85 × 85	NT	0.5	E50.N05-154NT0	10/FB12
215	1.8	5.2	30	2	6	182	60	85 × 110	NT	0.7	E50.N11-224NT0	10/FB10
250	1	4.2	60	4	12	211	40	85 × 136	NT	0.8	E50.N13-254NT0	10/FB15
270	2.5	4.2	40	2	10	228	40	85 × 136	NT	0.8	E50.N13-274NT0	10/FB15
300	2.4	4.2	40	2	6	234	40	85 × 136	NT	0.8	E50.N13-304NT0	10/FB15
360	1.2	3.2	75	3.9	11.7	304	50	85 × 176	NT	1.1	E50.N17-364NT0	5/FB8
430	1.3	2.8	75	3.9	11.8	363	55	85 × 200	NT	1.2	E50.N20-434NT0	5/FB12
500	0.52	2.7	80	7.5	22.5	423	40	116 × 140	NT	1.6	E50.R14-504NT1	6/FB15
560	1.8	2.3	60	4	12	473	60	85 × 252	NT	1.6	E50.N25-564NT0	5/FB10
645	0.6	2.3	80	7.3	21.9	545	40	116 × 165	NT	1.9	E50.R16-654NT0	3/FB8
760	0.71	2	70	7.6	22.8	642	45	116 × 190	NT	2.4	E50.R19-764NT0	3/FB12
825	0.68	1.7	120	11	32.9	697	60	116 × 220	NT	2.5	E50.R22-834NT0	3/FB12
1100	0.7	1.3	120	14.5	43.5	930	75	116 × 290	NT	3.3	E50.R29-115NT0	3/FB15
1200	0.64	1.5	120	15.9	47.7	1014	60	136 × 220	NT	3.4	E50.S22-125NT0	2/FB12
1460	1.2	1.1	90	7.3	21.9	1234	85	116 × 340	NT	3.9	E50.R34-155NT0	3/FB15
1680	0.91	1.2	60	10.5	31.5	1420	70	136 × 280	NT	4.3	E50.S28-175NT0	2/FB10
2000	0.82	1	120	15.9	47.7	1690	85	136 × 335	NT	5.2	E50.S33-205NT0	2/FB15
U_N 1500V DC		U_r 300V		U_s 2250V		U_{TT} 2250V DC		U_{Tc} 4800V AC/2s				
180	0.93	4.6	70	3.4	10.3	203	30	85 × 125	NT	0.8	E50.N12-184NT0	10/FB10
210	2.8	4.2	40	2	10	236	55	85 × 136	NT	0.8	E50.N13-214NT0	10/FB15
230	1.3	3.7	60	3.4	10.2	259	40	85 × 155	NT	1	E50.N15-234NT0	5/FB8
365	1.3	3.1	65	3.3	9.8	411	35	116 × 125	NT	1.4	E50.R12-374NT0	6/FB10
380	1.8	2.5	60	3.4	10.2	428	60	85 × 232	NT	1.5	E50.N23-384NT0	5/FB12
405	1.4	2.8	65	3.3	9.8	456	40	116 × 135	NT	1.5	E50.R13-414NT0	6/FB10
575	1.1	2.4	65	4.6	13.9	647	40	136 × 135	NT	2.1	E50.S13-584NT0	2/FB8
680	0.59	1.8	120	13	39.1	765	50	136 × 185	NT	2.9	E50.S18-684NT0	3/FB12
810	1	1.5	90	6.5	19.6	911	65	116 × 250	NT	2.9	E50.R25-814NT0	3/FB10
1095	0.89	1.1	120	9.8	29.3	1232	85	116 × 335	NT	3.8	E50.R33-115NT0	3/FB15
900	0.61	1.5	120	13.4	40.2	1012	60	136 × 220	NT	3.4	E50.S22-904NT0	2/FB12
1300	0.96	1.2	60	9.1	27.3	1463	70	136 × 280	NT	4.3	E50.S28-135NT0	2/FB10
1545	0.85	1	120	13.6	40.8	1721	85	136 × 335	NT	5.2	E50.S33-155NT0	2/FB15
U_N 1800V DC		U_r 400V		U_s 2700V		U_{TT} 2700V DC		U_{Tc} 5520V AC/2s				
120	2.6	5.2	30	1.5	5	194	60	85 × 110	NT	0.7	E50.N11-124NT0	10/FB10
275	1.9	2.5	60	2.9	8.7	446	60	85 × 232	NT	1.5	E50.N23-284NT0	5/FB12
390	2.2	2.1	40	2.6	7.8	632	50	116 × 180	NT	2.2	E50.R18-394NT0	3/FB12
630	1.2	1.4	90	5.4	16.2	1021	70	116 × 280	NT	3.2	E50.R28-634NT0	3/FB10
640	0.68	1.5	120	11.4	34.2	1037	60	136 × 220	NT	3.4	E50.S22-644NT0	2/FB12
920	1	1.2	60	7.8	23.4	1490	70	136 × 280	NT	4.3	E50.S28-924NT0	2/FB10
1085	0.88	1	120	11.6	34.8	1760	85	136 × 335	NT	5.2	E50.S33-115NT0	2/FB15



DATA CHARTS_ DATENTABELLEN_ E50. *** PK16™



E50.***PK16™
DC
2000...2800V



C_N (μF)	R_s ($m\Omega$)	R_{th} (K/W)	I_{max} (A)	\hat{I} (kA)	I_s (kA)	E_N (Ws)	L_e (nH)	$D_1 \times L_1$ (mm)	Design Maßbild	m (kg)	order no. Bestell-Nr.	pcs / Box Stk / Box
U_N 2000V DC		U_f 500V		U_s 3000V		U_{TT} 3000V DC		U_{TC} 6000 V AC/2s				
90	2.9	5.2	30	1.2	3.6	180	60	85 × 110	NT	0.7	E50.N11-903NT0	10/FB12
160	1	3.1	80	3.3	10	320	45	100 × 155	N5	1.3	E50.Q15-164N57	3/FB8
170	1.4	3.5	65	2.4	7.3	340	35	116 × 110	NT	1.4	E50.R11-174NT0	6/FB15
195	1.6	3.1	65	2.4	7.2	390	35	116 × 125	NT	1.4	E50.R12-204NT0	6/FB10
210	2.1	2.5	60	2.5	7.5	420	60	85 × 232	NT	1.5	E50.N23-214NT0	5/FB12
310	2.1	2.1	65	2.4	7.2	620	50	116 × 180	NT	2.1	E50.R18-314NT0	3/FB12
460	0.76	1.3	120	9.6	28.8	920	75	116 × 290	NT	3.3	E50.R29-464NT0	3/FB15
560	0.82	1.1	120	9.5	28.5	1120	85	116 × 340	NT	3.9	E50.R34-564NT1	3/FB15
480	0.71	1.5	120	9.7	29.1	960	60	136 × 220	NT	3.4	E50.S22-484NT0	2/FB12
700	1.1	1.2	60	6.7	20.1	1400	70	136 × 280	NT	4.3	E50.S28-704NT0	2/FB10
820	0.92	1	120	9.9	29.7	1640	85	136 × 335	NT	5.2	E50.S33-824NT0	2/FB15
U_N 2200V DC		U_f 600V		U_s 3300V		U_{TT} 3300V DC		U_{TC} 6480V AC/2s				
170	1.9	2.5	65	2.3	7	411	60	85 × 225	NT	1.4	E50.N22-174NT0	5/FB12
565	1.1	1.2	60	6	18	1367	70	136 × 280	NT	4.3	E50.S28-574NT0	2/FB10
665	0.95	1	120	8.9	26.7	1609	85	136 × 335	NT	5.2	E50.S33-674NT0	2/FB15
U_N 2600V DC		U_f 600V		U_s 3900V		U_{TT} 3900V DC		U_{TC} 7440V AC/2s				
95	2.9	3.2	40	1.9	5.8	321	60	85 × 176	NT	1.2	E50.N17-953NT0	5/FB8
175	1.6	2.1	65	3.6	10.7	592	40	116 × 180	NT	2.1	E50.R18-184NT0	3/FB8
270	0.66	1.5	120	14	43	913	60	136 × 220	NT	3.4	E50.S22-274NT0	2/FB12
350	1.2	1.1	90	7.2	21.5	1183	85	116 × 340	NT	3.9	E50.R34-354NT1	3/FB15
400	0.93	1.2	60	10	30	1352	70	136 × 280	NT	4.3	E50.S28-404NT0	2/FB10
465	0.82	1	120	15	45	1572	85	136 × 335	NT	5.2	E50.S33-474NT0	2/FB15
U_N 2800V DC		U_f 600V		U_s 4200V		U_{TT} 4200V DC		U_{TC} 7920V AC/2s				
100	1.7	2.5	60	3.5	10.5	392	60	85 × 232	NT	1.5	E50.N23-104NT0	5/FB12
245	0.66	1.5	120	14	42	960	60	136 × 220	NT	3.4	E50.S22-254NT0	2/FB12
420	0.82	1	120	14	42	1647	85	136 × 335	NT	5.2	E50.S33-424NT0	2/FB15



E50.***PK16™
DC
3000...3600V

C_N (μ F)	R_s (m Ω)	R_{th} (K/W)	I_{max} (A)	\hat{I} (kA)	I_s (kA)	E_N (Ws)	L_e (nH)	$D_1 \times L_1$ (mm)	Design Maßbild	m (kg)	order no. Bestell-Nr.	pcs / Box Stk / Box
U_N 3000V DC		U_r 600V		U_s 4500V		U_{TT} 4500V DC		U_{TC} 8400V AC/2s				
53	1.3	3.8	50	3.3	9.9	239	40	85 × 150	NT	1	E50.N15-533NT0	5/FB8
75	3.1	3.2	40	1.7	5.1	338	50	85 × 176	NT	1	E50.N17-753NT0	5/FB8
170	0.98	1.7	90	6.3	18.8	765	60	116 × 230	NT	2.6	E50.R23-174NT1	3/FB12
200	1.2	1.4	90	6	18.1	900	70	116 × 280	NT	3.2	E50.R28-204NT0	3/FB10
210	0.67	1.5	120	13	39	945	60	136 × 220	NT	3.4	E50.S22-214NT0	2/FB12
360	0.84	1	120	13	39	1620	85	136 × 335	NT	5.2	E50.S33-364NT0	2/FB15
U_N 3200V DC		U_r 700V		U_s 4800V		U_{TT} 4800V DC		U_{TC} 8880V AC/2s				
37.5	1.3	3.8	50	2.7	8.1	192	40	85 × 150	NT	1	E50.N15-383NT0	5/FB8
66.5	1.7	2.5	60	2.8	8.4	340	60	85 × 232	NT	1.5	E50.N23-673NT0	5/FB12
170	0.68	1.5	120	12	36	870	60	136 × 220	NT	3.4	E50.S22-174NT0	2/FB12
240	1	1.2	60	8	24	1229	70	136 × 280	NT	4.3	E50.S28-244NT0	2/FB10
285	0.86	1	120	12	36	1459	85	136 × 335	NT	5.2	E50.S33-294NT0	2/FB15
U_N 3600V DC		U_r 850V		U_s 5400V		U_{TT} 5400V DC		U_{TC} 9840V AC/2s				
30	2.5	4.7	35	1.4	4.1	194	35	85 × 120	NT	0.7	E50.N12-303NT0	10/FB10
32	1.3	3.8	50	2.4	7.2	207	40	85 × 150	NT	0.9	E50.N15-323NT0	5/FB8
40	3	3.9	40	1.4	4.3	259	40	85 × 146	NT	0.9	E50.N14-403NT0	5/FB8
165	0.95	1.1	120	7.5	22.6	1069	85	116 × 335	NT	3.9	E50.R33-174NT0	3/FB15
140	0.7	1.5	120	10.5	31.5	907	60	136 × 220	NT	3.4	E50.S22-144NT0	2/FB12
210	1.1	1.2	60	7	21	1361	70	136 × 280	NT	4.3	E50.S28-214NT0	2/FB10
250	0.88	1	120	11	33	1620	85	136 × 335	NT	5.2	E50.S33-254NT0	2/FB15



FE8



ultra low

high

PK MIND® – FIT FOR SiC:

ULTRA-LOW INDUCTANCE AND CONSTANT ESR

IDEAL FÜR SiC:

**ULTRANIEDRIGE INDUKTIVITÄT UND
KONSTANTER ESR**





PKmind® – Inductance as low as it can get

Our new PKmind® series is based on the SecuMet™ films known from the classic PK16. It merges its outstanding properties - high capacitance density with excellent long-term stability, particularly compact design, high rms currents up to 100 A rms, minimized series resistance and excellent surge current strength - with the low inductance of our E67 and E61 series, optimized for future high-frequency applications.

Externally quite similar to the PK16, the new capacitors have been redesigned completely on the inside. Thanks to innovative wiring and the connection configuration familiar from our E67 and E61, they achieve self-inductances of between 9 and 15 nH. Their much lower series resistance reduces power losses substantially and allows for even higher rms currents per unit than before. This is particularly important at the high frequency currents of future SiC applications with components in the range of 50 kHz and more. Inductance-related disturbances and self-resonances inside the capacitors can be minimized this way.

PKmind's diameters of 85 and 100 mm and its height between 102 and 180 mm are aimed at compact DC links, which are combined from several capacitors. In such a configuration, the surface area of the aluminium cases, as well as the bottom side of the can provide ample opportunity for cooling. As with the traditional PK16, it is fixed by an M12 stud at the base. The four robust, low-inductance M6 terminals (10 mm internal thread) are locked against excessive torque.

Filled with cured polyurethane resin, the capacitors are environmentally friendly and can be mounted in any position. All capacitors in this series are designed for climate class T1. With their lower temperature limit of -40°C, they are suitable even for harsh environmental conditions.

Important notice

Our capacitors of the PKmind® series are made with self-healing dielectric. Self-healing breakdowns become less likely, or impossible, under high thermal or electrical overstress. The disintegration of the polypropylene dielectric may produce more or less amounts of gas accompanied by a build-up of internal pressure. Very frequent and large-scale occurrence of self-healing breakdowns (e.g., as a result of strong voltage overstrain) may cause a gradual rise of the internal pressure as well.

For the sake of lowest available self-inductance and maximum mounting comfort, the capacitors of our PKmind® range are not equipped with an integrated safety mechanism. They should therefore not be operated beyond their rated values and be allocated in uncritical environment (non-flammable materials) where the release of flammable organic gases or an ignition of the polypropylene cannot cause consequential damage.

PKmind® – Induktivität, so niedrig es geht

Unsere neue Baureihe PKmind® basiert auf den vom klassischen PK16 her bekannten SecuMet™-Folien. Sie verschmilzt dessen herausragende Eigenschaften - hohe Kapazitätsdichte mit vorzüglicher Langzeitstabilität, besonders kompakte Bauweise, hohe Effektivströme bis zu 100 A rms, minimierter Serienwiderstand und exzellente Stoßstromfestigkeit - mit der auf künftige Hochfrequenzanwendungen optimierten niedrigen Induktivität unserer Baureihen E67 und E61.

Äußerlich dem PK16 durchaus ähnlich, sind die neuen Kondensatoren im Innern ganz neu konzipiert. Dank innovativer Verschaltung und der von E67 und E61 bekannten Anschlusskonfiguration erreichen sie Eigeninduktivitäten zwischen 9 und 15 nH. Ihr wesentlich verringerter Serienwiderstand reduziert Leistungsverluste ganz erheblich und ermöglicht noch höhere Effektivströme pro Kondensator als zuvor. Dies ist besonders wichtig für die hochfrequenten Betriebsströme künftiger SiC-Anwendungen mit Anteilen im Bereich von 50 kHz und mehr. Induktivitätsbedingte Störungen und kondensatorinterne Eigenresonanzen können so minimiert werden.

Die Durchmesser 85 und 100 mm des PKmind® und seine Bauhöhen zwischen 102 und 180 mm zielen auf kompakte Zwischenkreise, welche aus mehreren Kondensatoren kombiniert sind. In einer solchen Konfiguration bietet die Oberfläche der Aluminiumgehäuse und des Becherbodens eine großzügige Möglichkeit zur Kühlung. Wie bei den traditionellen PK16 erfolgt die Befestigung über einen M12x16-Montagebolzen. Die vier robusten, niederinduktiven M6-Anschlüsse (10-mm-Innengewinde) sind gegen zu hohes Drehmoment verriegelt.

Die mit ausgehärtetem Polyurethanharz gefüllten Kondensatoren sind umweltfreundlich und können in jeder Position montiert werden. Alle Kondensatoren in dieser Baureihe sind für Klimaklasse T1 ausgelegt. Mit ihrer unteren Temperaturgrenze von bis zu -40°C eignen sie sich selbst für raue Anwendungsumgebungen.

Wichtiger Hinweis

Alle in unseren PKmind®-Kondensatoren verwendeten dielektrischen Strukturen sind selbstheilend. Der zuverlässige Ablauf selbstheilender Durchschläge kann jedoch durch hohe thermische oder elektrische Belastung beeinträchtigt oder verhindert werden. Sich zersetzendes Polypropylen erzeugt dann größere Mengen an Gas und der Innendruck im Kondensator steigt. Gleichermaßen können großflächig auftretende Durchschläge (z.B. infolge starker Überspannung) einen starken Anstieg des Innendrucks verursachen. Zum Zwecke niedrigster Eigeninduktivität und maximalen Einbaukomforts verfügen die Kondensatoren der PKmind®-Reihe nicht über einen internen Abschaltmechanismus. Sie sollten daher nicht außerhalb ihrer zulässigen Nennwerte betrieben und stets in unkritischer Umgebung (nichtentflammare Materialien) platziert werden, wo die Freisetzung entzündlicher organischer Gase bzw. eine Entzündung des Dielektrikums keine schwerwiegenden Folgeschäden verursachen können.

PKmind[®] vs. PK16[™]

Comparison of PKmind[®] E80.Q15-524NLO and a traditional PK16 of same size and rating. Thanks to the ultra-low inductance of 9 vs. 35nH, and excellent internal design, the auto-resonance frequency of PKmind[®] is more than double, and there are no further resonance points beyond 200 kHz. For SiC, the frequencies above 50kHz will be most essential.

PKmind[®] vs. PK16[™]

PKmind[®] E80.Q15-524NLO und traditioneller PK16 gleicher Größe und Nennwerte im Vergleich. Dank ultraniedriger Induktivität von 9 gegenüber 35nH, und hervorragenden internen Designs liegt die Eigenresonanzfrequenz von PKmind[®] mehr als doppelt so hoch, und weist bis jenseits der 200 kHz keine weiteren Resonanzpunkte auf. Für SiC werden gerade die Frequenzen oberhalb 50 kHz am wichtigsten sein.

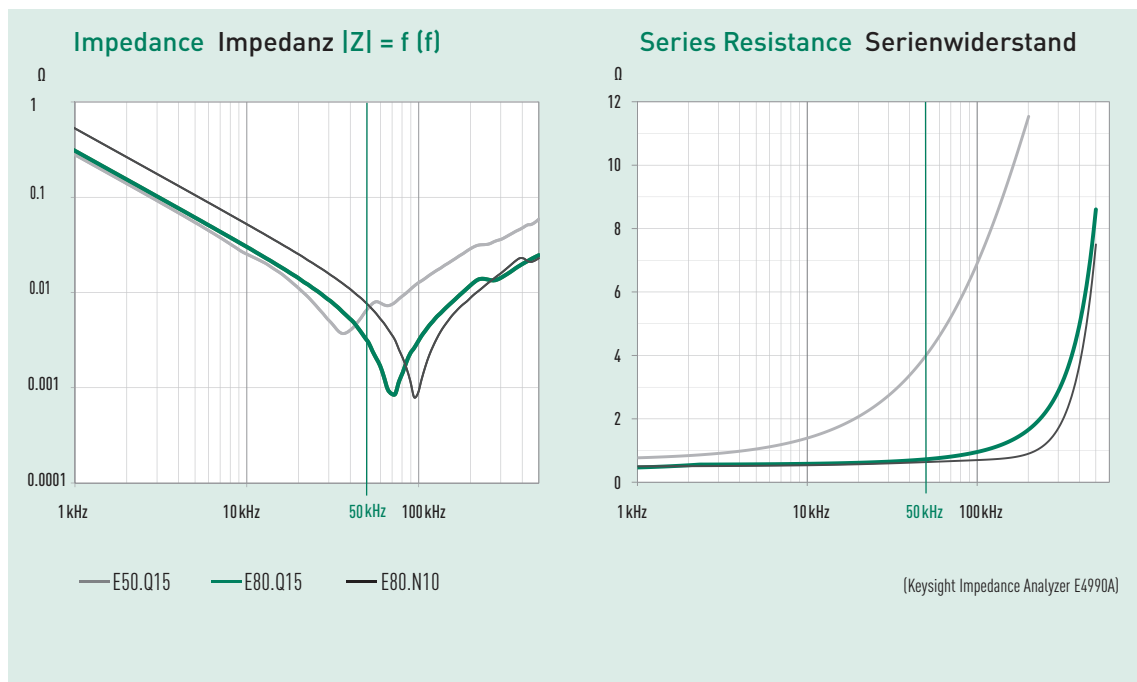

		Reference PK16 [™] E50.Q15-524N57	PKmind [®] E80.Q15-524NLO
Rated capacitance/voltage Nennkapazität/-spannung	C_N / U_N	520 μ F / 1100V	520 μ F / 1100V
Dimensions Abmessungen	$D_1 \times L_1$	\emptyset 100 \times 155 mm	\emptyset 100 \times 155 mm
Series resistance Serienwiderstand	R_s	0.7 m Ω	0.55 m Ω
Equivalent series resistance Ersatzwiderstand @ 10 kHz	ESR 10kHz	1 m Ω	0.58 m Ω
	ESR 100kHz	7 m Ω	1 m Ω
Rated current Nennstrom	I_{max}	80 A	100 A
Self-inductance Eigeninduktivität	L_e	35 nH	9 nH



E80.*** PKmind®
DC
600...900V

for latest edition and updates
check www.powercapacitors.info



Ultra-low-inductance DC capacitors
Extrem niederinduktive Zwischenkreiskondensatoren



Standards IEC 61071, optional IEC 61881
UL 810
can Gehäuse aluminium/plastic, (UL94: V0)
mounting position optional
Einbaulage beliebig
filling material solid PUR, based on plant oil
Füllmittel PUR ausgehärtet, auf Pflanzenölbasis
internal protection none
interne Sicherung keine
fire load Brandlast 40 MJ/kg

C_N tolerance Toleranz ±10%; optional ±5%
tanδ₀ 2 × 10⁻⁴
limit temperatures Grenztemperaturen
θ_{min} -40°C
θ_{max} (HOTSPOT) +85°C
storing temperature Lagertemperatur -40°C ... +85°C
Life time Lebensdauer > 200 000 h
Failure rate Ausfallrate 50 FIT¹

¹reference service life_Referenzbetriebsdauer 100 000 h, θ_{hotspot} ≤ 70°C



C _N (µF)	R _s (mΩ)	R _{th} (K/W)	I _{max} (A)	İ (kA)	I _s (kA)	E _N (Ws)	L _e (nH)	D ₁ × L ₁ (mm)	m (kg)	order no. Bestell-Nr.	pcs / Box Stk / Box
U_N 600V DC		U_r 100V		U_s 900V		U_{TT} 900V DC		U_{Tc} 3300V AC/2s			
470	0.66	3.1	80	5.8	17.4	529	9	85 × 102	0.7	E80.N10-474NLO	10/FB10
650	0.63	3.1	80	8.1	24.3	731	9	100 × 102	0.9	E80.Q10-654NLO	6/FB10
840	0.87	3.8	80	5.8	17.4	945	10	85 × 155	1.0	E80.N15-844NLO	5/FB8
1030	0.99	3.3	80	5.8	17.4	1159	12	85 × 181	1.2	E80.N18-105NLO	5/FB12
1200	0.75	3.1	100	8.2	24.6	1350	9	100 × 155	1.3	E80.Q15-125NLO	3/FB8
1500	0.7	2.8	100	8.4	25.4	1688	12	100 × 181	1.6	E80.Q18-155NLO	3/FB12
U_N 700V DC		U_r 200V		U_s 1050V		U_{TT} 1050V DC		U_{Tc} 3300V AC/2s			
350	0.69	3.1	80	5.1	15.3	394	9	85 × 102	0.7	E80.N10-354NLO	10/FB10
490	0.65	3.1	80	7.1	21.3	551	9	100 × 102	0.9	E80.Q10-494NLO	6/FB10
630	0.91	3.8	80	5	15	709	10	85 × 155	1.0	E80.N15-634NLO	5/FB8
770	1	3.3	80	5	15	866	12	85 × 181	1.2	E80.N18-774NLO	5/FB12
900	0.78	3.1	100	7.2	21.6	1013	9	100 × 155	1.3	E80.Q15-904NLO	3/FB8
1120	0.85	2.8	100	7.3	21.9	1260	12	100 × 181	1.6	E80.Q18-115NLO	3/FB12
U_N 900V DC		U_r 200V		U_s 1350V		U_{TT} 1350V DC		U_{Tc} 3360V AC/2s			
300	0.7	3.1	80	4.7	14.1	122	9	85 × 102	0.7	E80.N10-304NLO	10/FB10
440	0.65	3.1	80	6.9	20.7	178	9	100 × 102	0.9	E80.Q10-444NLO	6/FB10
530	0.9	3.8	80	4.6	13.8	215	10	85 × 155	1.0	E80.N15-534NLO	5/FB8
650	1.2	3.3	80	4.6	13.8	263	12	85 × 181	1.2	E80.N18-654NLO	5/FB12
780	0.6	3.1	100	6.8	20.4	316	9	100 × 155	1.3	E80.Q15-784NLO	3/FB8
955	0.75	2.8	100	6.8	20.4	387	12	100 × 181	1.6	E80.Q18-954NLO	3/FB12





C_N (μ F)	R_s (m Ω)	R_{th} (K/W)	I_{max} (A)	\hat{I} (kA)	I_s (kA)	E_N (Ws)	L_e (nH)	$D_1 \times L_1$ (mm)	m (kg)	order no. Bestell-Nr.	pcs / Box Stk / Box
U_N 1100V DC			U_f 250V		U_s 1650V		U_{TT} 1650V DC		U_{Tc} 3840V AC/2s		
200	0.85	3.1	80	3.9	11.7	121	9	85 × 102	0.7	E80.N10-204NLO	10/FB10
290	0.5	3.1	80	5.6	16.8	175	9	100 × 102	0.9	E80.Q10-294NLO	6/FB10
370	1.2	3.8	80	4	12	224	10	85 × 155	1.0	E80.N15-374NLO	5/FB8
440	1.3	3.3	80	3.9	11.7	266	12	85 × 181	1.2	E80.N18-444NLO	5/FB12
520	0.55	3.1	100	5.6	16.8	315	9	100 × 155	1.3	E80.Q15-524NLO	3/FB8
650	0.7	2.8	100	5.7	17.1	393	12	100 × 181	1.6	E80.Q18-654NLO	3/FB12
U_N 1300V DC			U_f 300V		U_s 1950V		U_{TT} 1950V DC		U_{Tc} 4320V AC/2s		
130	0.9	3.1	80	3.1	9.3	110	9	85 × 102	0.7	E80.N10-134NLO	10/FB10
195	0.55	3.1	80	4.7	14.1	165	9	100 × 102	0.9	E80.Q10-194NLO	6/FB10
235	1.3	3.8	80	3.1	9.3	199	10	85 × 155	1.0	E80.N15-234NLO	5/FB8
290	1.4	3.3	80	3.2	9.6	245	12	85 × 181	1.2	E80.N18-294NLO	5/FB12
350	0.75	3.1	100	4.6	13.8	296	9	100 × 155	1.3	E80.Q15-354NLO	3/FB8
420	0.85	2.8	100	4.6	13.8	355	12	100 × 181	1.6	E80.Q18-424NLO	3/FB12
U_N 1500V DC			U_f 300V		U_s 2250V		U_{TT} 2250V DC		U_{Tc} 4800V AC/2s		
100	0.93	3.1	80	2.7	8.1	113	9	85 × 102	0.7	E80.N10-104NLO	10/FB10
140	0.6	3.1	80	3.8	11.4	158	9	100 × 102	0.9	E80.Q10-144NLO	6/FB10
180	1.2	3.8	80	2.7	8.1	203	10	85 × 155	1.0	E80.N15-184NLO	5/FB8
220	1.4	3.3	80	2.7	8.1	248	12	85 × 181	1.2	E80.N18-224NLO	5/FB12
250	0.84	3.1	100	3.7	11.1	281	9	100 × 155	1.3	E80.Q15-254NLO	3/FB8
300	0.93	2.8	100	3.7	11.1	343	12	100 × 181	1.6	E80.Q18-304NLO	3/FB12
U_N 2000V DC			U_f 500V		U_s 3000V		U_{TT} 3000V DC		U_{Tc} 6000V AC/2s		
71,5	0.6	4.7	65	2.6	7.8	143	9	100 × 102	0.9	E80.Q10-723NLO	6/FB10
130	1.1	3.3	70	2.6	7.8	260	10	100 × 155	1.3	E80.Q15-134NLO	3/FB8
165	1	3.2	70	2.7	8.1	330	12	100 × 181	1.6	E80.Q18-174NLO	3/FB12
U_N 2300V DC			U_f 600V		U_s 3450V		U_{TT} 3450V DC		U_{Tc} 6720V AC/2s		
60	0.7	4.7	65	2.4	7.2	159	9	100 × 102	0.9	E80.Q10-603NLO	6/FB10
110	1	3.3	70	2.6	7.8	291	10	100 × 155	1.3	E80.Q15-114NLO	3/FB8
135	1.1	3.2	70	2.5	7.5	357	12	100 × 181	1.6	E80.Q18-144NLO	3/FB12



ЕВ



E61 – DIRECTLY ONTO BUS BAR OR PCB:

HIGH CURRENTS AND LOW INDUCTANCE

DIREKT AUF SAMMELSCHIENE ODER LEITERPLATTE:

HOHE STRÖME UND NIEDRIGE INDUKTIVITÄT

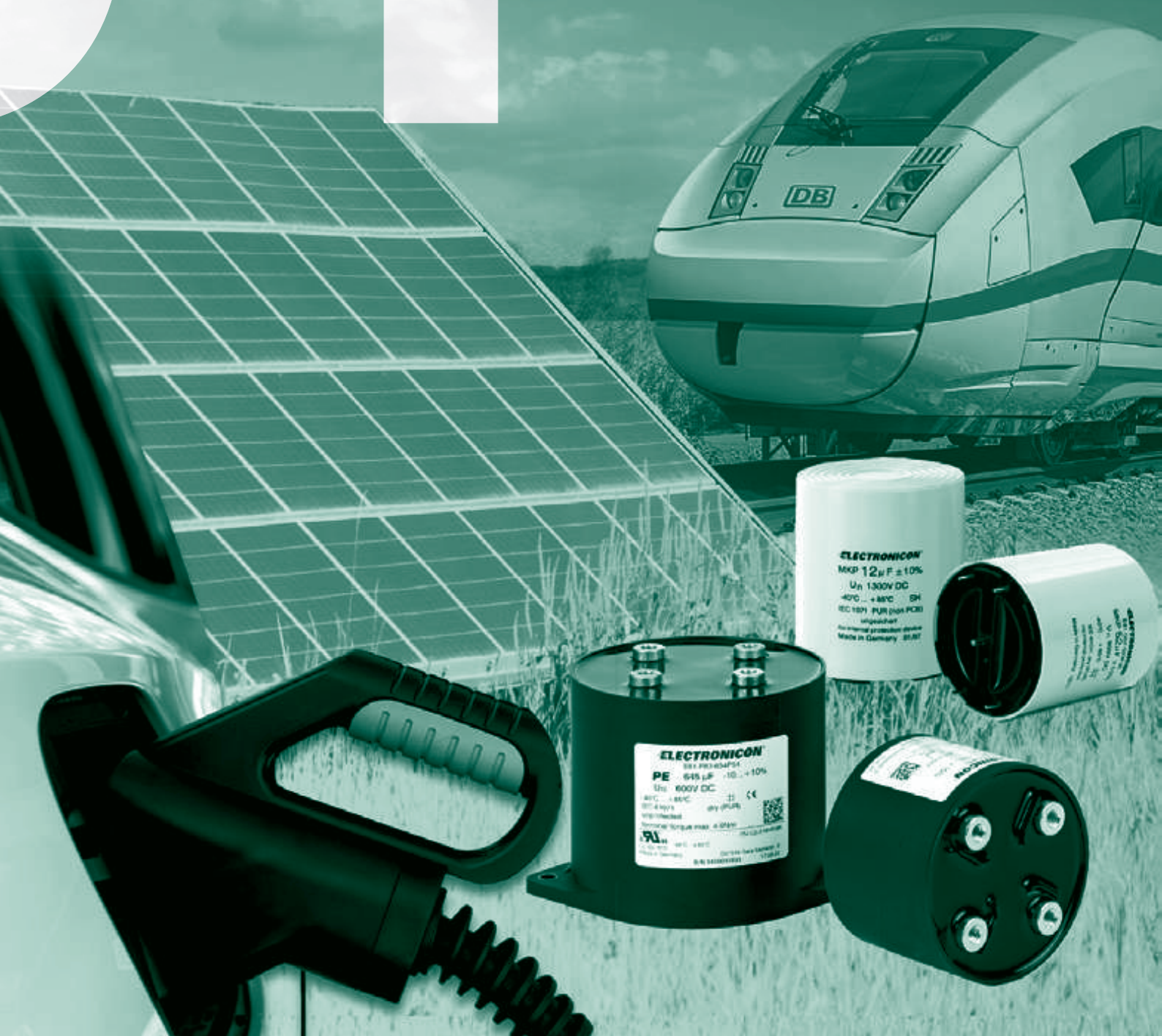

THE LOW-CAPACITANCE BUFFER CIRCUIT DER KAPAZITÄTSARME ZWISCHENKREIS

3-Phase Frequency converters with Low-Capacitance DC-Link (LCDC)

Robots, elevators, assembly lines, processing centers, tooling machines – high process speed and further improvement of automation levels are unthinkable without frequency controlled AC drives. And it would not be possible to achieve the optimum operating characteristics at an economically feasible utilization level of available resources.

Most of the contemporary 3-phase frequency converters are working with a DC link, mainly using electrolytic capacitors to buffer the DC voltage. When selecting the electrolytic capacitors, the dominating criteria are the AC current load and the required operating life time. As a rule, this leads to the installation of large banks of electrolytic capacitors even though the large capacitance as such would not even be necessary for the buffering as such. These days, decentralized motors with integrated drive are becoming more and more popular. The advantages of this topology are more intelligent and flexible interconnection and control of the individual systems, as well as simplified and more convenient maintenance conditions. At the same time, developers are tasked to improve the technical performance of the electronic drives, reduce their mechanical dimensions and – of course – cost.



The „LCDC“ (DC buffer circuit with low, or small, capacitance) complies with all these requirements and has become possible with the high density DC film capacitors designed and manufactured by ELECTRONICON.

The capacitors of the E61 series are optimized for use in DC Link circuits with high rms and surge currents. The pin or screw terminals allow for direct integration into your printed circuit board or bus bar.

The winding is placed inside a flame retardant housing filled with solid resin (PUR). In order to minimize self-inductance and dimensions, the E61-capacitors are not equipped with an internal fail-safe device.

Capacitors with their comparably high fire load (appr. 40MJ/kg) do always bear a certain risk of collateral damage in the event of a failure. It is therefore necessary to place them in uncritical environment or integrate other proper measures of prevention.

Frequenzumrichter am 3-Netz mit kapazitätsarmem Zwischenkreis

Ob Roboter, Aufzüge, Fertigungsstraßen, Bearbeitungszentren, Werkzeugmaschinen - ohne frequenzgesteuerte Drehstromantriebe sind hohe Prozessgeschwindigkeiten und eine weitere Verbesserung des Automatisierungsgrades nicht zu erreichen. Ebensovienig wäre es möglich, die optimale Betriebscharakteristik bei einem aus betriebswirtschaftlicher Sicht günstigen Einsatz der vorhandenen Mittel zu erreichen. Die meisten der heute eingesetzten 3-Phasen-Frequenzumrichter arbeiten mit einem Gleichspannungszwischenkreis. Zur Pufferung der Gleichspannung werden überwiegend Elektrolyt-Kondensatoren verwendet. Bei deren Dimensionierung sind die Wechselstrombelastung und die geforderte Lebensdauer die entscheidenden Kriterien. Dies führt zumeist zum Einsatz großer Batterien von Elektrolyt-Kondensatoren, obwohl die Gesamtkapazität zur Pufferung gar nicht benötigt wird. Zur Zeit gewinnen dezentral aufgestellte Motoren mit integriertem Antrieb immer mehr an Bedeutung. Die Vorteile dieser Topologie liegen in der flexibleren und intelligenteren Vernetzung und Ansteuerung der einzelnen Systeme, sowie in einem übersichtlicheren Wartungsaufwand. Einhergehend mit dieser Technologie werden an die Entwickler die Forderungen gestellt, die technische Performance der elektronischen Antriebe zu verbessern, die mechanischen Abmaße zu verkleinern und die Kosten zu reduzieren.

Eine Alternative, die allen diesen Forderungen gerecht wird, ist der „Niederkapazitive Gleichspannungszwischenkreis“, welcher dank der von ELECTRONICON entwickelten HD-DC-Kondensatoren möglich wurde.

E61-Kondensatoren sind optimal für die Anwendung in Gleichspannungszwischenkreisen mit hohen Effektiv- und Spitzenströmen. Die Pin- oder Schraub-Anschlüsse können zur direkten Montage auf der Leiterplatte oder Sammelschiene genutzt werden. Der Kondensatorwickel ist in einem flammhemmenden Gehäuse untergebracht und mit Harz vergossen. Die Forderung minimierter Eigeninduktivität und Gehäuseabmessungen lässt bei Kondensatoren dieser Bauart keinen integrierten Sicherheitsmechanismus zu.

Da Kondensatoren mit ihrer verhältnismäßig hohen Brandlast (ca. 40MJ/kg) im Fehlerfall stets ein gewisses Risiko für Folgeschäden bergen, ist es geboten, sie nur in unkritischer Umgebung oder in Verbindung mit zusätzlichen Vorbeugemaßnahmen zu installieren.



Example

Comparison between a DC link with electrolytic capacitors and film capacitors of our E61 series

(5kW drive, $\Theta_{\text{ambient}} = 70^{\circ}\text{C}$, target life time > 50.000 h):

Beispiel

Vergleich zwischen Gleichspannungszwischenkreisen mit Elektrolyt-Kondensatoren und solchen mit E61-Folienkondensatoren

(5kW Umrichter, $\Theta_{\text{Umgebung}} = 70^{\circ}\text{C}$, angestrebte Lebensdauer > 50.000 h):

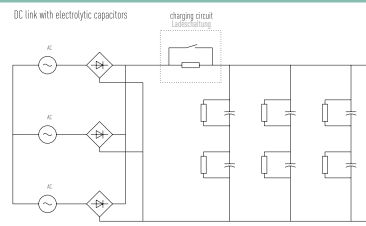
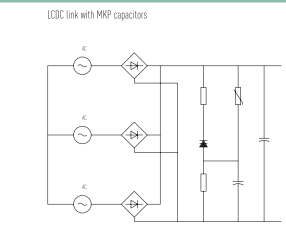
	Elyt* 1300µF/450V	E61 48µF/900V
Circuitry	DC link with electrolytic capacitors 	LCDC link with MKP capacitors 
ESR @ 300Hz	110 mΩ	4,3 mΩ
I_{rms} @ 300Hz	8 A	35 A
D × L	40 × 96 mm	50 × 57 mm
Volume per unit Volumen pro Einheit	120 cm ³	112 cm ³
Weight per unit Gewicht pro Einheit	170 g	120 g
Required quantity Benötigte Menge	6	1
Total volume installed Installiertes Gesamtvolumen	6 × 120 cm ³ = 720 cm ³	112 cm ³
Total weight installed Installiertes Gesamtgewicht	6 × 170 g = 1020 g	120 g

* example: market leading manufacturer
* Beispiel: marktführender Hersteller

Interactions with mains

The comparison of mains currents in the graphic to the right shows that the necessity for filtering is substantially reduced as well:

Netrückwirkungen

Die in der Grafik zur rechten dargestellten Netzströme bedürfen hinsichtlich des erforderlichen Filteraufwandes sicher keines Kommentars:

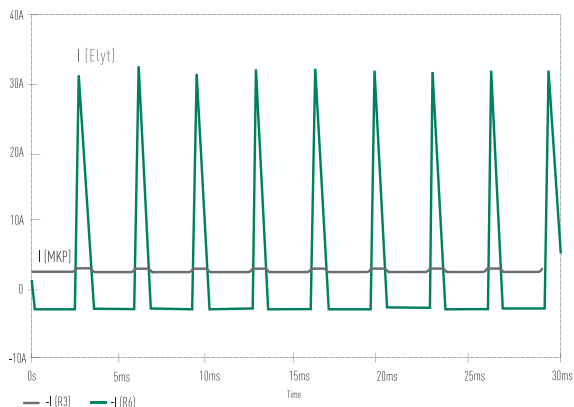

Cost advantages

Presuming that the expenses for the sharing resistors and the charging circuit of the electrolytic capacitors equals more or less the cost of the additional buffering for the MKP circuit, we get a cost reduction by factor 5 when using MKP capacitors instead of electrolytic capacitors. This does not yet consider indirect savings by improved reliability of the final product, reduced power losses a.o.

Kostenvorteil

Veranschlagt man den Aufwand für Ladeschaltung und Symmetrierung der Elektrolytkondensatoren etwa genauso wie die nötige Pufferschaltung beim MKP-Zwischenkreis, so ergibt sich für MKP-Kondensatoren eine Kostenreduktion um Faktor 5 gegenüber Elko's, und das sogar ohne Berücksichtigung indirekter Einsparungen dank erhöhter Zuverlässigkeit, reduzierter Leistungsverluste u.ä.



E61.***
DC
500...900V

for latest edition and updates
check www.powercapacitors.info



Low-inductance DC capacitors
Niederinduktive DC-Kondensatoren

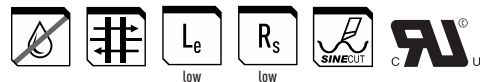

Standards IEC 61071, optional IEC 61881, UL 810
can Gehäuse plastic Kunststoff (UL94: V0)
mounting position optional
Einbaulage beliebig
filling material solid, based on vegetable oil, non-PCB
Füllmittel ausgehärtet, auf Pflanzenölbasis, PCB-frei
internal protection none
interne Sicherung keine
fire load Brandlast 40 MJ/kg

C_N tolerance Toleranz ±10%
tanδ₀ 2 x 10⁻⁴
limit temperatures Grenztemperaturen
 θ_{min} ... θ_{max} -25°C ... +85°C
 θ_{HOTSPOT} +85°C
storing temperature Lagertemperatur -40°C ... +85°C
Life time Lebensdauer > 200 000 h
Failure rate Ausfallrate 50 FIT
(reference service life_Referenzbetriebsdauer 100 000 h, θ_{HOTSPOT} <70°C)

C _N (µF)	R _S (mΩ)	R _{th} (K/W)	I _{max} (A)	Î (kA)	I _S (kA)	E _N (Ws)	L _e (nH)	D ₁ × L ₁ (mm)	Design Maßbild	m (kg)	order no. Bestell-Nr.	pcs / Box Stk / Box
U_N 500V DC		U_S 750V		U_r 170V		U_{TT} 750V DC						
85	2	10.9	35	1.1	3.3	11.9	45	50 × 57	P3	0.12	E61.G57-853P3**	12 / FB4
195	3.4	7.4	25	1.1	3.3	24.4	66	50 × 95	P3	0.18	E61.G95-204P3**	12 / FB4
208	0.79	7.5	50	2.6	8	26	15	75 × 56	P5	0.3	E61.M56-214P5*	12 / FB4
260	5.2	6.1	30	1.1	3.3	32.5	110	50 × 120	P3	0.21	E61.G12-264P3**	12 / FB4
358	0.64	4.7	70	4	13	45	20	95 × 56	P5	0.48	E61.P56-364P5*	12 / FB4
542	0.57	3.1	80	8	26	68	25	95 × 83	P5	0.7	E61.P83-544P5*	12 / FB4
645	0.84	3.1	70	4	13	81	25	95 × 83	P5	0.7	E61.P83-654P5*	12 / FB4
U_N 700V DC		U_S 1050V		U_r 200V		U_{TT} 1050V DC						
58	1.9	10.9	30	0.9	2.7	14.2	45	50 × 57	P3	0.12	E61.G57-583P3**	12 / FB4
142	3.5	7.4	30	0.93	2.8	34.8	66	50 × 95	P3	0.18	E61.G95-144P3**	28 / FB4
154	0.85	7.5	50	2.2	7	38	15	75 × 56	P5	0.3	E61.M56-154P5*	28 / FB4
190	4.7	6.1	25	0.91	2.73	46.6	66	50 × 120	P3	0.21	E61.G12-194P3**	12 / FB4
265	0.67	4.7	65	4	11	65	20	95 × 56	P5	0.48	E61.P56-274P5*	12 / FB4
402	0.58	3.1	80	8	22	98	25	95 × 83	P5	0.7	E61.P83-404P5*	8 / FB2
480	0.89	3.1	70	4	11	118	25	95 × 83	P5	0.7	E61.P83-484P5*	8 / FB2
U_N 900V DC		U_S 1350V		U_r 200V		U_{TT} 1350V DC						
36	2.4	10.9	35	0.7	2.1	14.6	45	50 × 57	P3	0.12	E61.G57-363P3**	28 / FB4
45	2.1	10.9	35	0.8	2.4	18.2	45	50 × 57	P3	0.12	E61.G57-453P3**	28 / FB4
48	2.2	10.9	35	0.85	2.55	19.4	45	50 × 57	P3	0.12	E61.G57-483P3**	28 / FB4
112	4.1	7.4	32	0.84	2.52	43.7	66	50 × 95	P3	0.18	E61.G95-114P3**	12 / FB4
131	0.85	7.5	45	2.1	6.2	53	15	75 × 56	P5	0.3	E61.M56-134P5*	12 / FB4



*) 7 - without mounting brackets _ ohne Montagelasche
 4 - with mounting brackets _ mit Montagelasche

**) Details design P3C and P30 see page 42
 Details zu den Anschlüssen P3C und P30 siehe Seite 42

Other values and dimensions available on request.
 Andere Werte und Abmessungen auf Anfrage erhältlich.



C_N (μ F)	R_S (m Ω)	R_{th} (K/W)	I_{max} (A)	\hat{I} (kA)	I_S (kA)	W_N (Ws)	L_e (nH)	$D_1 \times L_1$ (mm)	Design Maßbild	m (kg)	order no. Bestell-Nr.	pcs / Box Stk / Box
U_N 900V DC		U_S 1350V		U_F 260V		U_{TT} 1350V DC						
155	6	6.1	30	0.85	2.55	62.8	66	50 × 120	P3	0.21	E61.G12-164P3**	21 / FB2
226	0.69	4.7	65	3.6	10.7	92	20	95 × 56	P5	0.5	E61.P56-234P5*	21 / FB2
358	0.56	3.1	80	7.1	21.4	145	25	95 × 83	P5	0.7	E61.P83-364P5*	21 / FB2
409	0.94	3.1	70	3.6	10.7	166	25	95 × 83	P5	0.7	E61.P83-414P5*	21 / FB2
U_N 1100V DC		U_S 1650V		U_F 250V		U_{TT} 1650V DC						
30	2.8	10.9	20	0.64	1.92	18.2	45	50 × 57	P3	0.12	E61.G57-303P3**	28 / FB4
73	4.5	7.4	25	0.66	1.98	44	66	50 × 95	P3	0.18	E61.G95-733P3**	28 / FB4
83.5	1.01	7.5	40	1.6	5	51	15	75 × 56	P5	0.3	E61.M56-843P5*	28 / FB4
100	6.1	6.1	25	0.66	1.98	60.5	66	50 × 120	P3	0.21	E61.G12-104P3**	28 / FB4
144	0.76	4.7	60	2.8	8	87	20	95 × 56	P5	0.48	E61.P56-144P5*	28 / FB4
218	0.62	3.1	80	5.6	16	132	25	95 × 83	P5	0.7	E61.P83-224P5*	8 / FB2
260	1.05	3.1	65	2.8	8	157	25	95 × 83	P5	0.7	E61.P83-264P5*	8 / FB2
U_N 1300V DC		U_S 1950V		U_F 300V		U_{TT} 1950V DC						
12	4	10.9	20	0.38	1.14	10	45	50 × 57	P3	0.12	E61.G57-123P3**	21 / FB2
16.5	3	10.9	20	0.47	1.41	14	45	50 × 57	P3	0.12	E61.G57-173P3**	21 / FB2
40.5	5.7	7.4	25	0.49	1.47	34	66	50 × 95	P3	0.18	E61.G95-413P3**	21 / FB2
55	7.7	6.1	25	0.49	1.47	46	66	50 × 120	P3	0.21	E61.G12-553P3**	21 / FB2
56	1.13	7.5	40	1.3	4	47	15	75 × 56	P5	0.3	E61.M56-563P5*	21 / FB2
96	0.84	4.7	60	2.3	7	81	20	95 × 56	P5	0.48	E61.P56-963P5*	8 / FB2
145	0.65	3.1	75	4.6	14	123	25	95 × 83	P5	0.7	E61.P83-154P5*	8 / FB2
173	1.17	3.1	60	2.3	7	146	25	95 × 83	P5	0.7	E61.P83-174P5*	8 / FB2
U_N 2000V DC		U_S 3000V		U_F 500V		U_{TT} 3000V DC						
24	1.42	7.5	35	0.9	2.8	48	15	75 × 56	P5	0.3	E61.M56-243P5*	12 / FB4
41.5	1	4.7	50	1.6	5	83	20	95 × 56	P5	0.48	E61.P56-423P5*	12 / FB4
63	0.71	3.1	75	3.2	10	126	25	95 × 83	P5	0.7	E61.P83-633P5*	12 / FB4
72	1.48	3.1	55	1.5	5	144	25	95 × 83	P5	0.7	E61.P83-723P5*	12 / FB4
U_N 2200V DC		U_S 3300V		U_F 600V		U_{TT} 3300V DC						
18	1.62	7.5	35	0.8	2.3	44	15	75 × 56	P5	0.3	E61.M56-183P5*	12 / FB4
31	1.12	4.7	50	1.3	4	75	20	95 × 56	P5	0.48	E61.P56-313P5*	12 / FB4
50	0.73	3.1	70	3	10	121	25	95 × 83	P5	0.7	E61.P83-503P5*	12 / FB4
58	1.68	3.1	50	1.4	4	140	25	95 × 83	P5	0.7	E61.P83-583P5*	12 / FB4
U_N 2600V DC		U_S 3900V		U_F 600V		U_{TT} 3900V DC						
12	1.24	7.5	35	1.3	4	41	15	75 × 56	P5	0.3	E61.M56-123P5*	12 / FB4
21	0.89	4.7	50	2.2	7	71	20	95 × 56	P5	0.48	E61.P56-213P5*	12 / FB4



*) 7 - without mounting brackets _ ohne Montagelasche
4 - with mounting brackets _ mit Montagelasche

**) Details design P3C and P30 see page 42
Details zu den Anschlüssen P3C und P30 siehe Seite 42



E61.***

DC

3300...4000V



C_N (μF)	R_S ($m\Omega$)	R_{th} (K/W)	I_{max} (A)	\hat{I} (kA)	I_S (kA)	E_N (Ws)	L_e (nH)	$D_1 \times L_1$ (mm)	Design Maßbild	m (kg)	order no. Bestell-Nr.	pcs / Box Stk / Box
U_N 3300V DC		U_S 4950V		U_F 700V		U_{TT} 4950V DC						
7	1.42	7.5	30	1	3	38	15	75 × 56	P5	0.3	E61.M56-702P5*	12 / FB4
12.5	0.98	4.7	45	1.8	5	68	20	95 × 56	P5	0.48	E61.P56-133P5*	12 / FB4
24	1.39	3.1	50	1.8	5	131	25	95 × 83	P5	0.7	E61.P83-243P5*	12 / FB4
U_N 3600V DC		U_S 5400V		U_F 850V		U_{TT} 5400V DC						
6	1.52	7.5	25	0.9	2.8	39	15	75 × 56	P5	0.3	E61.M56-602P5*	12 / FB4
10	1.09	4.7	40	1.5	5	65	20	95 × 56	P5	0.48	E61.P56-103P5*	12 / FB4
20.5	1.48	3.1	45	1.6	5	133	25	95 × 83	P5	0.7	E61.P83-213P5*	12 / FB4
U_N 4000V DC		U_S 6000V		U_F 800V		U_{TT} 6000V DC						
3.5	1.92	7.5	25	0.7	2	28	15	75 × 56	P5	0.3	E61.M56-352P5*	12 / FB4
6.5	1.24	4.7	40	1.3	4	52	20	95 × 56	P5	0.48	E61.P56-652P5*	12 / FB4

*) 7 - without mounting brackets _ ohne Montagelasche
4 - with mounting brackets _ mit Montagelasche



ACCESSORIES, DIMENSION DRAWINGS

ZUBEHÖR, MASSZEICHNUNGEN





Holding Brackets for PK16™

To fulfill specific shock and vibration requirements, tall capacitors may not be sufficiently fixed by their mounting stud alone. Made from glass-fibre reinforced plastic (UL94-V0) with a brass thread, these clamps are designed to secure our GA85 and the 136mm diameter PK16 capacitors to each other and to the mounting surface. They provide additional stability during transport and operation. This construction has been tested successfully for compliance with railway shock and vibration standard IEC EN 61373.

The position of the holders can be arranged at will. Each capacitor should, however, be held by at least two, ideally by three or four brackets which should be allocated as symmetrically as possible. Achieve optimum stability by using the triple brackets for interlinking neighboring capacitor units.

Due to the internal temperature rise, capacitors are subject to slight expansion during operation. Use elastical plastic thread bars only for the link with the base plate to compensate for such expansion. 1m rods, washers and M8 full nuts can be provided as a kit along with the brackets.

Description Beschreibung	Qty/set Menge/Set	order no. Bestell-Nr.
single bracket Einzelhalter	10	
full size nut Vollmutter M8	10	E50.H01-10M8A8
toothed washer Zahnscheibe A 8.4	10	
triple bracket Dreifachhalter	10	
full size nut Vollmutter M8	10	E50.H03-10M8A8
toothed washer Zahnscheibe A 8.4	10	
threaded plastic rod Plastikzahnstange l = 1.0 m, M8, Polyamide 6.6	10	E50.GM8-PA1000

Halteklammern für PK16™

Um speziellen Anforderungen an die Stoß- und Schwingungsbeständigkeit zu genügen, reicht bei hohen Kondensatoren die Befestigung allein mittels Bodenbolzen u.U. nicht aus. Diese Klammern aus glasfaserverstärktem Kunststoff (UL94-V0) mit Messinggewinde sind gedacht für die Verankerung unserer GA85 sowie der PK16-Kondensatoren des Durchmessers 136 mm, sowohl untereinander als auch mit dem Montageuntergrund. Sie schaffen zusätzliche Stabilität für Transport und Betrieb. Die Konstruktion wurde erfolgreich nach IEC EN 61373 (Betriebsmittel von Bahnfahrzeugen – Prüfungen für Schwingen und Schocken) getestet.

Die Position der Halter kann nach Belieben gestaltet werden. Jeder Kondensator sollte jedoch mindestens durch zwei, besser drei oder vier, möglichst symmetrisch angeordnete Klammern fixiert werden. Verwenden Sie für optimale Stabilität die Dreier-Klammern, um benachbarte Kondensatoren miteinander zu verbinden.

Infolge Erwärmung dehnen sich Kondensatoren im Betriebszustand etwas aus. Verwenden Sie für die Verankerung in der Grundplatte ausschließlich elastische Zahnstangen aus Kunststoff, um eine solche Ausdehnung auszugleichen. 1-Meter-Zahnstangen, M8-Vollmutter und Zahnscheiben können als Zubehör-set geliefert werden.

Required length of threaded rod Erforderliche Länge der Zahnstange:

$$L_{rod} = L_1 - 22mm + Y$$

L_{rod} Length of rod Länge der Zahnstange
 L_1 Length of capacitor case Gehäuselänge des Kondensators
 Y Thickness of mounting base Dicke der Montagebasis

Drawings Maßbilder

triple bracket Dreifachhalter

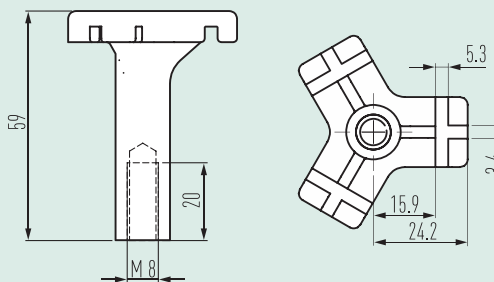

single bracket Einzelhalter

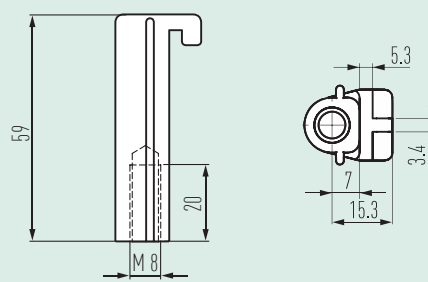



Suggested arrangements Einbauvorschläge (Design NT, Ø 136)

symmetrical installation symmetrische Anordnung

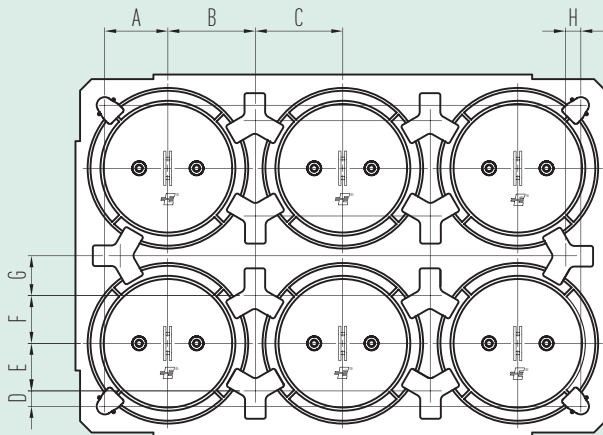

A	54.5
B	76.3
C	76.3
D	15.5
E	39
F	39
G	37.3
H	15.8

shifted installation versetzte Anordnung

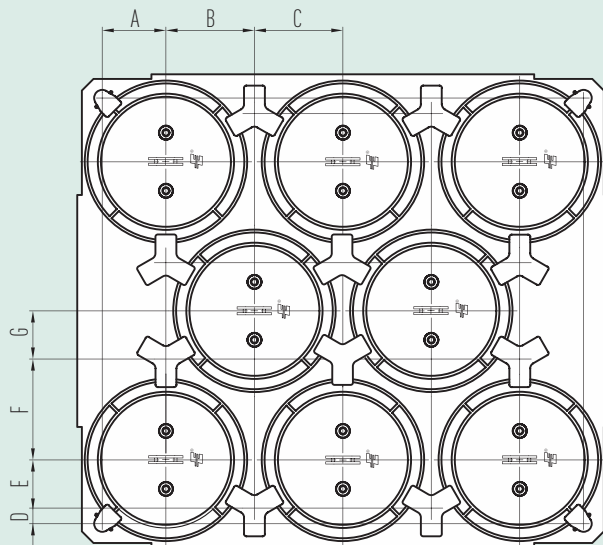

A	54.5
B	76.3
C	76.3
D	15.5
E	39
F	86
G	39





Terminal Adapter

Customers who wish to connect their capacitors by male M8 terminals can upgrade our standard NT design by means of these adapters.

Please note: By inserting the adapters, the terminal level is elevated by 3mm.

Anschlussadapter M6x10-M8x20

Kunden, welche für ihre Anwendung Gewindebolzen mit M8 Außengewinde bevorzugen, können die Anschlüsse unserer Standardausführung NT mithilfe dieser Adapter nachrüsten.

Bitte beachten Sie, daß die Anschlußebene hierbei um 3mm angehoben wird.

Order no. Bestellnr. 200.050-A20970

material Material tinned brass Messing, verzinkt
thread Gewinde M6 × 10 mm / M8 × 20 mm
fixing torque Drehmoment 4 Nm
max. rms current max. Effektivstrom 80 A

Drawings Maßbilder

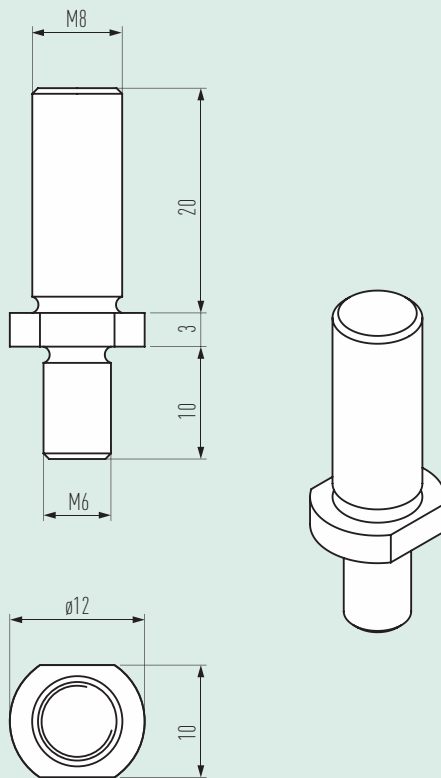

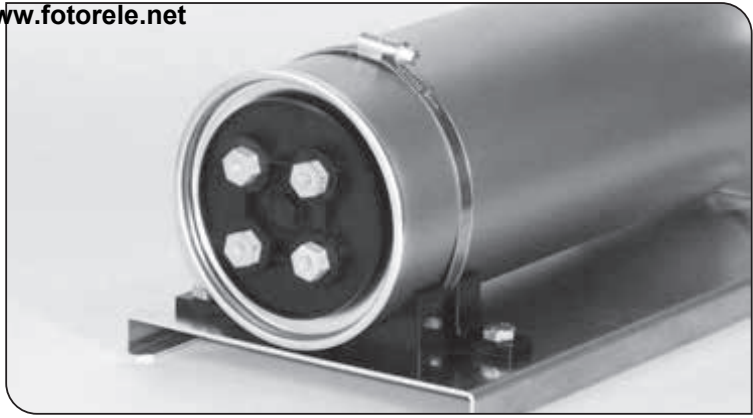

Holder for Horizontal Mounting

All cylindrical capacitors with diameter 116mm and 136mm can be mounted by means of this bracket on a flat vertical or horizontal surface.

The bracket is made of glass fibre reinforced polyamide and comes as a set including a matching 9mm zinc-plated steel strap for fixation of the capacitor.

Halter für waagerechte Montage

Alle zylindrischen Kondensatoren mit Durchmesser 116mm und 136mm können mit Hilfe dieser Schelle auf einer senkrechten oder waagerechten Oberfläche montiert werden.

Der Halter ist aus glasfaserverstärktem Polyamid und wird inklusive passender 9mm-Schlauchschelle aus verzinktem Stahl geliefert.

Drawings Maßbilder

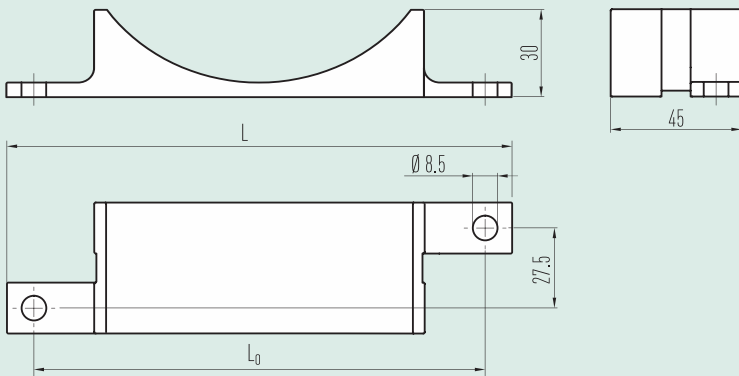

material Material glass fibre reinforced polyamide glasfaserverstärktes Polyamid

Example of PK16 capacitor Beispiel PK16-Kondensator

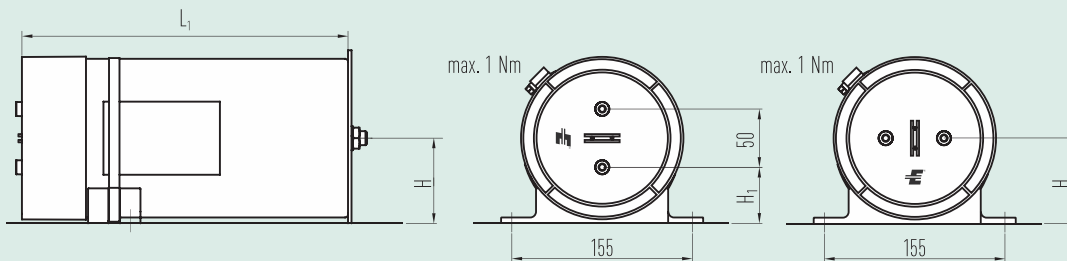

Example of horizontal mounting.
Beispiel für eine waagerechte Befestigung.

for Diameter für Durchmesser	L	L ₀	H	H ₁	order no. (10 × mounting set) Bestell-Nr. (10 × Montage-Set)
116	159	135	64	38	E50.H16-100000
136	174	155	74	48	E50.H36-100001





Design W4 / W6

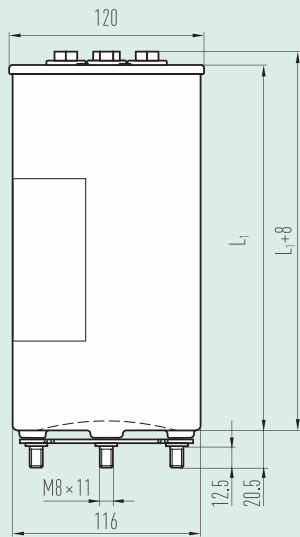

W4

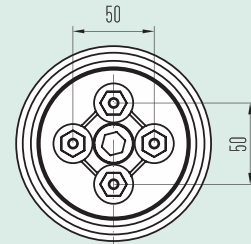

W6

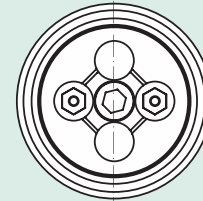

bottom view

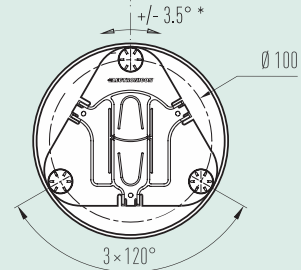

Principal circuit diagram
Prinzipschaltbild



* Due to the manufacturing process, the position of the base screws in relation to the connections may deviate by up to 3.5° in both directions.
Fertigungsbedingt kann die Position der Bodenschrauben zu den Anschlüssen um bis zu 3,5° in beide Richtungen abweichen.

E67 CAPACITORS

Can material	aluminium, filled with neutral gas (N ₂)
Lid	aluminium, folded edge
Terminals	plastic insulator (UL94: V0)
internal thread	iM6 × 12 mm (7.5 Nm), tinned brass with nickel barrier
I_{max} (Terminals)	120 A
Degree of protection	IP 00
K W4	25 mm
W6	33 mm
L W4	19.5 mm
W6	19.5 mm
Humidity Class	C, TX (IEC 62498-1)

E67 KONDENSATOREN

Gehäusematerial	Aluminium, gefüllt mit neutralem Gas (N ₂)
Deckel	Aluminium, gebördelt
Anschlüsse	Kunststoffisolator (UL94: V0)
Innengewinde	iM6 × 12 mm (7.5 Nm) Messing verzinkt, mit Nickelsperrschicht
I_{max} (Anschlüsse)	120 A
Schutzgrad	IP 00
K W4	25 mm
W6	33 mm
L W4	19.5 mm
W6	19.5 mm
Feuchteklasse	C, TX (IEC 62498-1)



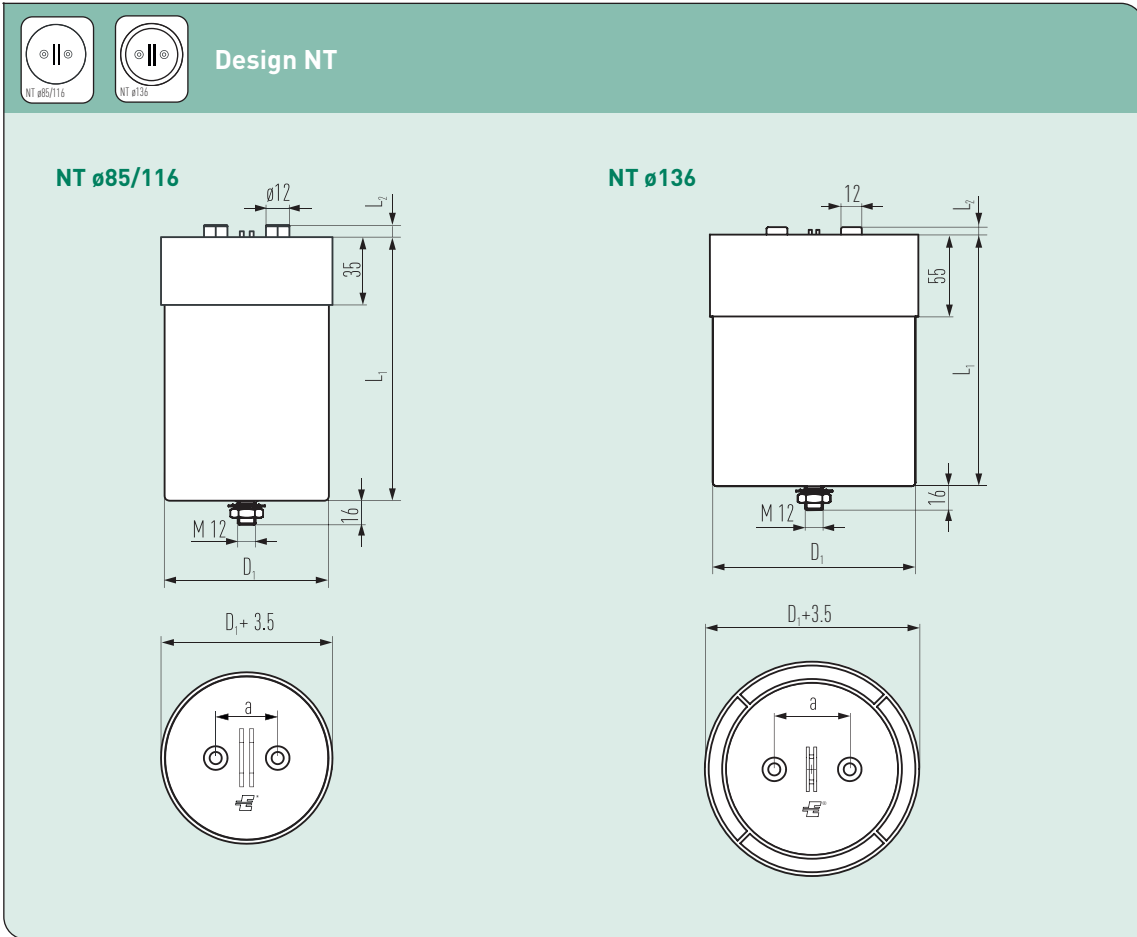

E50 CAPACITORS WITH A CAN DIAMETER OF 85...136 mm

Can materialaluminium, filled with solid PU resin

Base mounting studM12

Lidplastic (UL94: V0)

Terminalsinternal thread iM6 × 10 mm (4 Nm),
tinned brass with nickel barrier

Degree of protectionIP 00

Humidity ClassT1 (IEC 62498-1)

E50 KONDENSATOREN MIT GEHÄUSEDURCHMESSER 85...136 mm

Gehäusematerial Aluminium, gefüllt mit ausgehärtetem
Polyurethanharz

Bodenschraube M12

Deckel Kunststoff (UL94: V0)

Anschlüsse Innengewinde iM6 × 10 mm (4 Nm),
Messing verzinkt, mit Nickelsperrschicht

Schutzgrad IP 00

Feuchtklasse T1 (IEC 62498-1)

Design	K	L	L ₂	a	I _{max} (Terminals Anschlüsse)
NT ø85	36	20	6	32	90 A
NT ø116/136	45	35	5	50	120 A





Design N5



Design N4

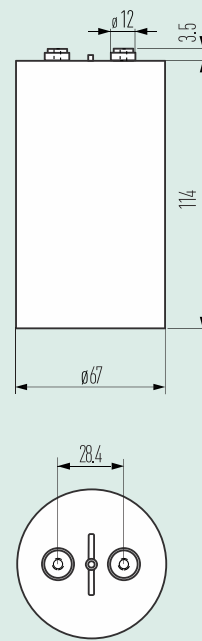
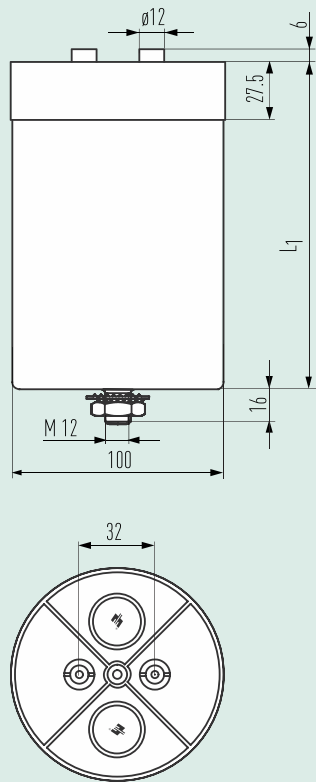

E50 CAPACITORS WITH A CAN DIAMETER OF 100 mm

Can material:

- N5**..... aluminium, filled with solid PU resin, plastic lid (UL94: V0)
- N4**..... plastic (UL94: V0), filled with solid PU resin

Terminals..... internal thread, tinned brass with nickel barrier

- N5**..... iM6 × 10 mm (4 Nm)
- N4**..... iM5 × 6 mm (2 Nm)

Degree of protection..... IP 00

Humidity Class

- N5**..... T1 (IEC 62498-1)
- N4**..... G

E50 KONDENSATOREN MIT GEHÄUSEDURCHMESSER 100 mm

Gehäusematerial:

- N5**..... Aluminium, gefüllt mit ausgehärtetem Polyurethanharz, Kunststoffdeckel (UL94: V0)
- N4**..... Kunststoff (UL94: V0), gefüllt mit ausgehärtetem Polyurethanharz

Anschlüsse..... Innengewinde, Messing verzinkt, mit Nickelsperrschicht

- N5**..... iM6 × 10 mm (4 Nm)
- N4**..... iM5 × 6 mm (2 Nm)

Schutzgrad..... IP 00

Feuchteklasse

- N5**..... T1 (IEC 62498-1)
- N4**..... G

Design	K	L	I _{max} (Terminals Anschlüsse)
N4	25	16	30 A
N5	36	20	80 A





Design NL0

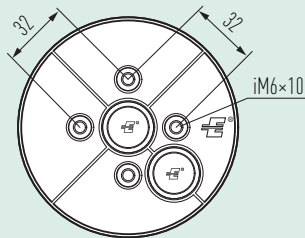
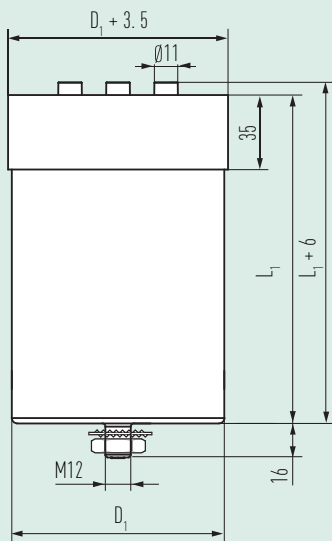

Principle circuit diagram
Prinzipschaltbild



E80 CAPACITORS WITH A CAN DIAMETER OF 85 ... 100 mm

Can materialaluminium
Base mounting studM12
Lidplastic UL94-V0
Terminalstinned brass, internal thread iM6 × 10 mm (4Nm)
I_{max} (Terminals)120 A
Degree of protectionIP 00
K40 mm
L20 mm
Humidity classT1 (IEC 62498-1)

E80 KONDENSATOREN MIT DURCHMESSER 85 ... 100 mm

GehäusematerialAluminium
BodenschraubeM12
DeckelKunststoff UL94-V0
AnschlüsseMessing verzinkt, Innengewinde iM6 × 10 mm (4Nm)
I_{max} (Anschlüsse)120 A
SchutzgradIP 00
K40 mm
L20 mm
FeuchtklasseT1 (IEC 62498-1)





Design P54/P57

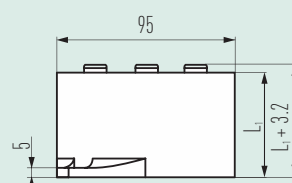
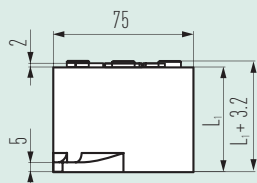

P54

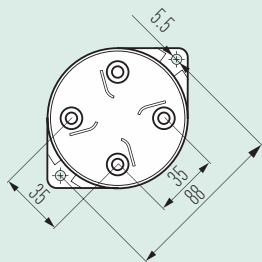

P54

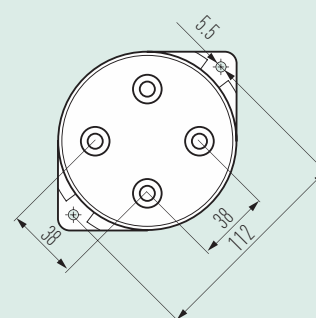

P57

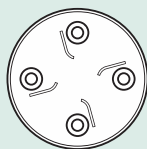

P57

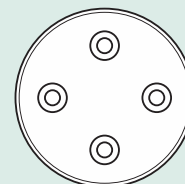

Principal circuit diagram
Prinzipschaltbild



E61 CAPACITORS WITH A CAN DIAMETER OF 75...95 mm

Can material	flame-retardant plastic, filled with PU resin
Fixing	P57 can be fixed by terminals on PCB or bus bar
Terminals	internal threads iM6 × 5mm, tinned brass with nickel barrier
I_{max} (Terminals)	40 A
Degree of protection	IP 00
L ø 75	23 mm
L ø 95	26 mm
K	26 mm
Humidity class	T1 (IEC 62498-1)

E61 KONDENSATOREN MIT DURCHMESSER 75...95 mm

Gehäusematerial	flammhemmender Kunststoff, PU-Harzfüllung
Befestigung	P57 mit Anschlüssen direkt auf Leiterplatte/ Sammelschiene aufschraubbar
Anschlüsse	Innengewinde iM6 × 5 mm, Messing verzinkt, mit Nickelsperrschicht
I_{max} (Anschlüsse)	40 A
Schutzgrad	IP 00
L ø 75	23 mm
L ø 95	26 mm
K	26 mm
Feuchtklasse	T1 (IEC 62498-1)





P3



Design P3

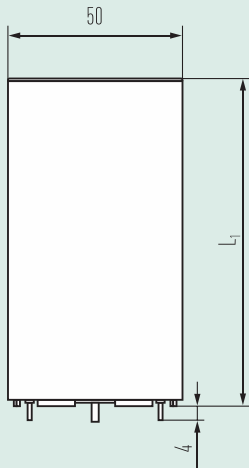

P3C

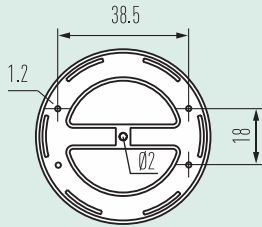

P30

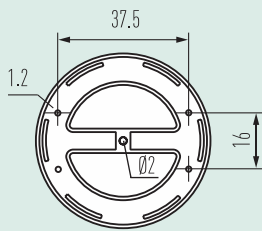

Principle circuit diagram

Prinzipschaltbild

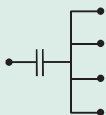

E61 CAPACITORS WITH A CAN DIAMETER OF 50 mm

Can material flame-retardant plastic (UL94: V0).
filled with solidified PUR resin

Terminals tinned copper wire Ø 1.2 mm / 2 mm

I_{max} (Terminals) 35 A

Degree of protection IP 00

K 17.5 mm

L 17.5 mm

Humidity class T1 (IEC 62498-1)

E61 KONDENSATOREN MIT DURCHMESSER 50 mm

Gehäusematerial Flammhemmender Kunststoff (UL94: V0).
gefüllt mit ausgehärtetem Polyurethanharz

Anschlüsse Kupferdraht Ø 1.2 mm / 2 mm, verzinkt

I_{max} (Anschlüsse) 35 A

Schutzgrad IP 00

K 17.5 mm

L 17.5 mm

Feuchtklasse T1 (IEC 62498-1)



ANNEX ANHANG

Important Remarks

General

Our catalogues outline the typical technical and mechanical characteristics of the listed capacitors. The stated values are based on reference type tests, as well as empirical and experimental experience. The real values of individual capacitors may differ within the stated, or commonly known, tolerances. Any information given in this catalogue therefore describes the components in general terms and does not constitute any guarantee of individual technical values.

It is the responsibility of the user to ensure by dedicated tests the suitability and safety of operation of our components under the conditions of his application. This also applies to any accessories offered by ELECTRONICON.

Safety

Safe operation of the capacitors can be expected only if all safety recommendations as well as electrical and thermal specifications as stated on the label, in the data sheets, catalogues and the accompanying mounting instructions are strictly observed, and recommended safety devices are used as intended. Please consider the "General Safety Recommendations" of the power capacitor manufacturers organized in the German ZVEI (www.electronicon.com/en/zvei).

The capacitors shall only be used for the intended application. ELECTRONICON will not indemnify or be responsible for any kind of damages to persons or property due to the improper application of any capacitors purchased from ELECTRONICON or its distributors.

Mind that electrical or mechanical misapplication of capacitors can become hazardous. Misapplied capacitors can explode or catch fire and cause bodily injury or property damage due to the expulsion of material or metal fragments.

Please consult the detailed instructions for mounting and application stated in our brochure „Application Notes“ and on the ELECTRONICON website: www.electronicon.com/en/an

If in doubt about how to connect, operate, or discharge a capacitor, consult ELECTRONICON engineering or our distributors.

Mounting And Cooling

The useful life of a capacitor may be reduced dramatically if exposed to excessive heat. Typically an increase in the ambient temperature of 7°C will halve the expected life of the capacitor. Make sure to obey the permitted operating temperatures.

To avoid overheating the capacitors must be allowed to cool unhindered and should be shielded from external heat sources. We recommend forced ventilation for all filter applications with reactors. Give approx. 20mm clearance around capacitors for natural or forced ventilation, and do not place them directly above or next to heat sources such as detuning or tuning reactors, bus bars, etc.

Wichtige Hinweise

Allgemeines

Unsere Kataloge beschreiben die typischen technischen und mechanischen Eigenschaften der aufgeführten Kondensatoren. Die angegebenen Werte basieren auf Referenztypprüfungen sowie empirischen und experimentellen Erfahrungswerten. Die tatsächlichen Werte einzelner Kondensatoren können innerhalb der angegebenen bzw. allgemein bekannter Toleranzen abweichen. Alle Angaben in diesem Katalog beschreiben daher die Komponenten im Allgemeinen und stellen keine Garantie für individuelle technische Werte dar.

Es liegt in der Verantwortung des Anwenders, durch gezielte Prüfungen die Eignung und Betriebssicherheit unserer Komponenten unter den konkreten Betriebsbedingungen seiner Anwendung sicherzustellen. Dies gilt ebenso für gegebenenfalls von ELECTRONICON angebotene Zubehörteile.

Sicherheit

Ein sicherer Betrieb der Kondensatoren ist nur zu erwarten, wenn alle Sicherheitsempfehlungen sowie elektrische und thermische Spezifikationen entsprechend Etikett, Datenblättern, Katalogen und beiliegenden Montageanleitungen eingehalten und die empfohlenen Sicherheitseinrichtungen bestimmungsgemäß verwendet werden. Bitte beachten Sie die „Allgemeinen Sicherheitsempfehlungen“ der im deutschen ZVEI organisierten Hersteller von Leistungskondensatoren (www.electronicon.com/zvei).

Die Kondensatoren dürfen ausschließlich für ihren Bestimmungszweck verwendet werden. ELECTRONICON übernimmt keine Verantwortung oder Haftung für Schäden an Personen oder Eigentum, welche aus unsachgemäßer Anwendung von Kondensatoren herrührt.

Elektrisch oder mechanisch fehlerhaft eingesetzte Kondensatoren können explodieren oder Feuer fangen. Austretende Materialien bzw. Metallteile können gesundheitliche und materielle Schäden verursachen.

Bitte beachten Sie die detaillierten Anweisungen in unserer Broschüre „Anwendungshinweise“ sowie auf der Webseite von ELECTRONICON: www.electronicon.com/an

Bitte konsultieren Sie das Fachpersonal oder unsere Distributoren zu Fragen bezüglich Anschluss, Verwendung oder Entladung von Kondensatoren.

Montage und Kühlung

Die Lebensdauer eines Kondensators kann durch übermäßige Wärmeeinwirkung erheblich verringert werden. Im allgemeinen führt eine Erhöhung der Umgebungstemperatur um 7°C zu einer Verringerung der Lebensdauer des Kondensators um 50 %. Halten Sie die zugelassenen Betriebstemperaturen ein.

Um Überhitzung zu vermeiden, muß gewährleistet sein, daß die Kondensatoren auftretende Verlustwärme ungehindert abführen können und vor fremden Wärmequellen abgeschirmt werden. Insbesondere in Filtern ist in jedem Falle eine Zwangslüftung zu empfehlen. Zwischen und um Kondensatoren sollten etwa 20mm Platz für natürliche oder Zwangslüftung belassen werden. Bringen Sie den Kondensator nie direkt neben oder über Wärmequellen, wie Drosseln u. ä. an.

Protection against Overvoltages And Short Circuits: Self-Healing Dielectric

All dielectric structures used in our power capacitors are „selfhealing“: In the event of a voltage breakdown the metal layers around the breakdown channel are evaporated by the temperature of the electric arc that forms between the electrodes. They are removed within a few microseconds and pushed apart by the pressure generated in the centre of the breakdown spot. An insulation area is formed which is reliably resistive and voltage proof for all operating requirements of the capacitor. The capacitor remains fully functional during and after the breakdown.

For voltages within the permitted testing and operating limits the capacitors are short-circuit- and overvoltage-proof. They are also proof against external short circuits as far as the resulting surge discharges do not exceed the specified surge current limits.

Failure Rate

The failure probability of a component is a statistical value which is described by a log-normal distribution:

$$N = N_0 \times e^{-\lambda t}$$

λ is the failure rate, which alternatively is also stated as the so-called FIT-rate (FIT = Failures In Time = $\lambda \times 10^9$).

The failure rate is very closely linked with operating temperature and operating voltage of the capacitor. The FIT rates stated in this catalogue are related to the capacitor's rated voltage and a dielectric temperature (= HOTSPOT temperature) of 70°C.

The simultaneous operation of capacitors at highest permissible voltage and operating temperature should be avoided; otherwise, failure rates may increase beyond reasonable technical reliability.

The standard reference period for the failure rate statement is 100.000 hours. Please note that FIT rates can be altered or improved by technical adjustments. Please contact us for details.

The following diagram demonstrates the correlation between FIT rate, operating voltages and operating temperatures.

Schutz gegen Überspannungen und Kurzschlüsse: Selbstheilendes Dielektrikum

Alle in unseren Leistungskondensatoren eingesetzten dielektrischen Strukturen sind selbstheilend. Im Falle eines Kurzschlusses (Spannungsdurchschlag) verdampfen die Metallbeläge um den Durchschlagpunkt herum infolge des Lichtbogens, der sich zwischen den Elektroden bildet. Binnen Mikrosekunden wird der Metaldampf vom Zentrum des Durchschlages weggedrückt. Auf diese Weise bildet sich eine isolierende belagfreie Zone um den Durchschlagpunkt. Der Kondensator bleibt während und nach dem Durchschlag voll funktionsfähig.

Für Spannungen innerhalb der zugelassenen Test- und Betriebsbedingungen sind die Kondensatoren kurzschluss- und überspannungssicher. Sie sind außerdem sicher gegen äußere Kurzschlüsse, sofern bei den dabei entstehenden Stoßentladungen die zugelassenen Stoßströme nicht überschritten werden.

Ausfallrate

Die Ausfallwahrscheinlichkeit eines Bauelements ist eine statistische Größe, die mit Hilfe einer Normalverteilung beschrieben wird. Es gilt:

N = number of functional components after period t
Anzahl der nach der Zeit t intakten Bauelemente
 N_0 = total number of components at time $t = 0$
Gesamtzahl der Bauelemente zum Zeitpunkt $t = 0$
 λ = failure rate Ausfallrate

Dabei ist λ die Ausfallrate, die alternativ auch als FIT-Rate angegeben wird (FIT = $\lambda \times 10^9$)

Die Ausfallrate ist stark abhängig von der Temperatur und der Betriebsfeldstärke. Die FIT-Raten im Katalogsortiment beziehen sich auf 70°C Dielektrikumstemperatur (=Hotspot-Temperatur) und die Nennspannung des Kondensators.

Der Betrieb von Kondensatoren mit der höchsten zulässigen Spannung und der höchsten zulässigen Betriebstemperatur sollte vermieden werden, andernfalls können die Ausfallraten so hoch werden, dass keine technisch sinnvollen Zuverlässigkeiten mehr gewährleistet sind.

Der Wert für die Ausfallrate bezieht sich auf einen Referenzzeitraum von 100.000h. FIT-Raten können durch technische Anpassung der Kondensatoren beeinflusst und verbessert werden. Auskünfte hierzu erteilen wir auf Anfrage.

Das nachstehende Kurvendiagramm macht den Zusammenhang von FIT-Rate, Betriebsspannung und Betriebstemperatur deutlich.



ANNEX
ANHANG

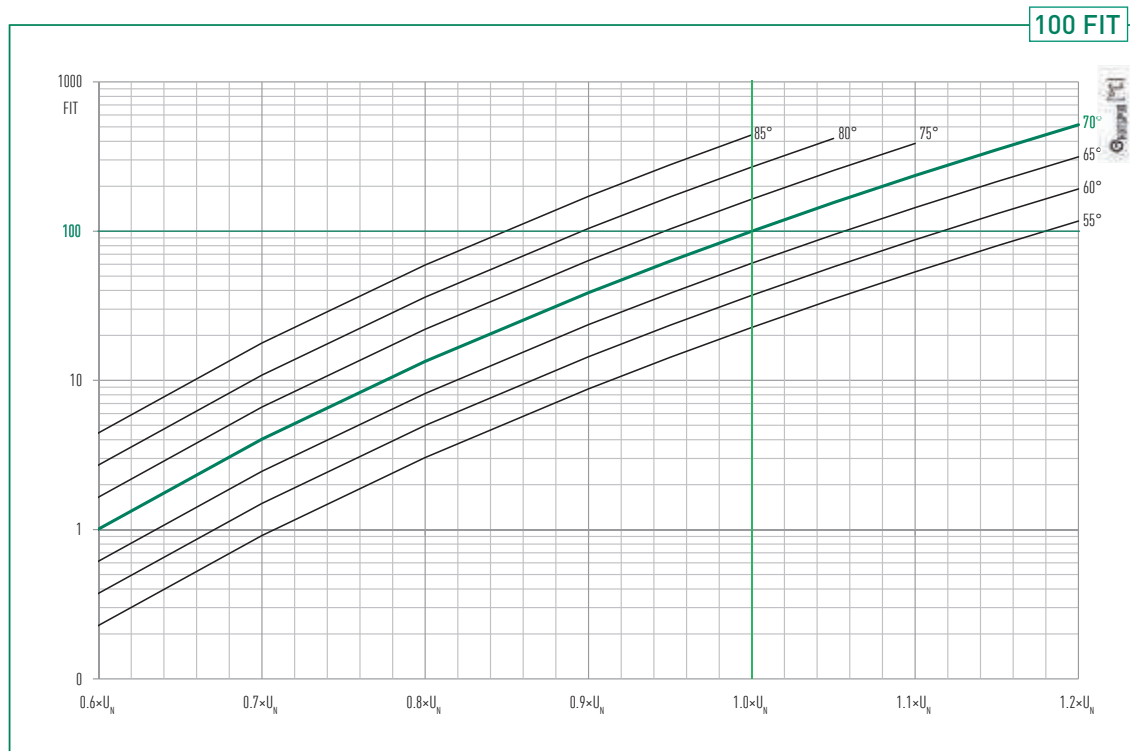
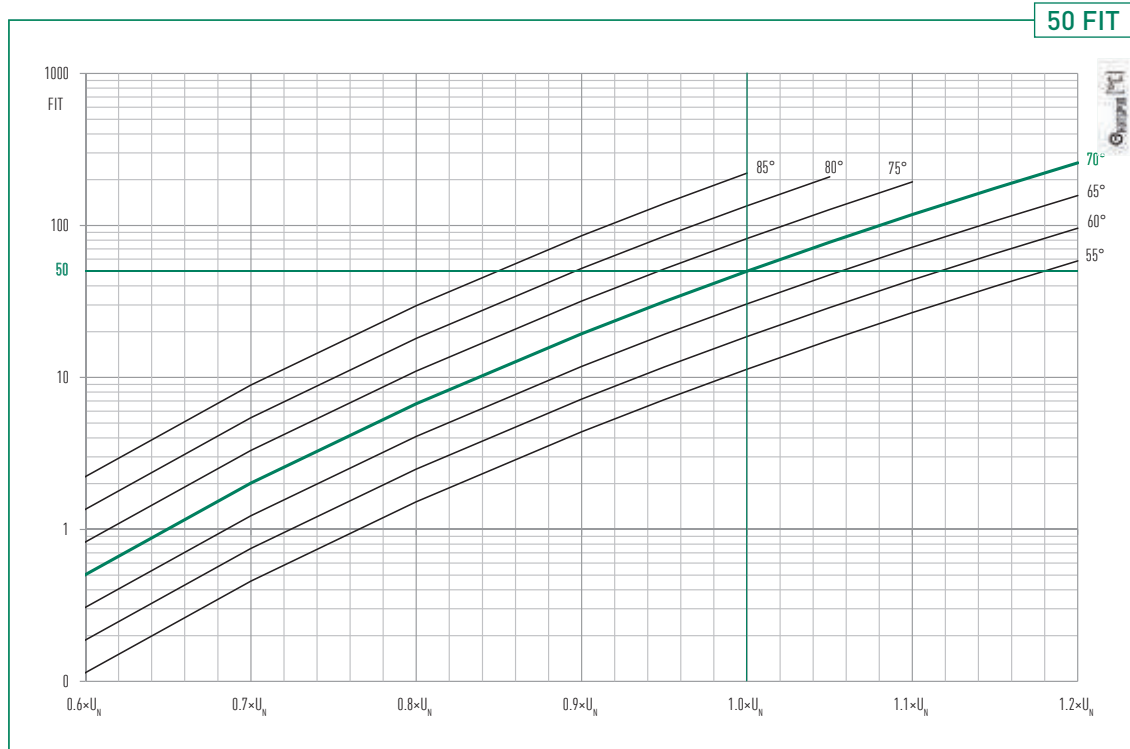

Limited Warranty

All our products are designed, manufactured, and tested with the highest care and workmanship. The satisfaction of our customers is our highest goal. We therefore warrant remedying any defect in the goods resulting from faulty design, materials or workmanship, which appears within 2 years from the date of sale, unless agreed otherwise.

This warranty does not cover defects due to improper use of the goods or operation at conditions exceeding the rated values stated in the catalogue or special data sheet. Nor does it cover defects due to faulty maintenance or incorrect installation, alterations or faulty repairs undertaken by the Buyer. Finally the warranty does not cover normal wear and tear or deterioration.

See our „General Conditions“ for details on Warranty and Product liability.

Gewährleistung

Alle unsere Erzeugnisse werden mit höchster Sorgfalt und Fachkenntnis entwickelt, hergestellt und geprüft. Die Zufriedenheit unserer Kunden ist unser höchstes Ziel. Wir verpflichten uns daher, sofern nicht anders vereinbart, jeden innerhalb von 2 Jahren ab Verkaufsdatum auftretenden Mangel an unseren Erzeugnissen zu beseitigen, welcher aus Fehlern in Design, Material oder Herstellung herrührt.

Diese Gewährleistung erstreckt sich nicht auf Defekte infolge unsachgemäßer Anwendung oder Betrieb außerhalb der nach Katalog oder Datenblatt zulässigen Einsatzbedingungen. Sie erfaßt ebensowenig Schäden aufgrund fehlerhafter Wartung, unsachgemäßer Montage, Änderungen oder unsachgemäßer Reparaturen durch den Käufer bzw. Anwender. Diese Gewährleistung betrifft auch nicht normale Abnutzung und Verschleiß.

Siehe unsere „Allgemeinen Geschäftsbedingungen“ für Details zu Gewährleistung und Produkthaftung.

Find more information and detailed instructions in our „Application Notes“ and on www.electronicon.com
Mehr Informationen und ausführliche Anweisungen finden Sie in unseren „Anwendungshinweisen“ und unter www.electronicon.com

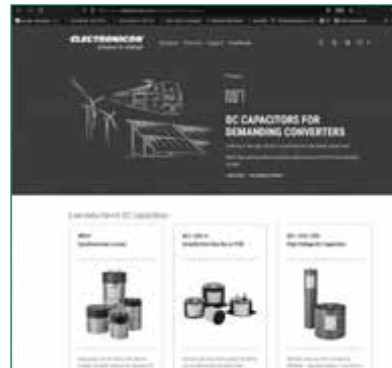

NOTES
NOTIZEN

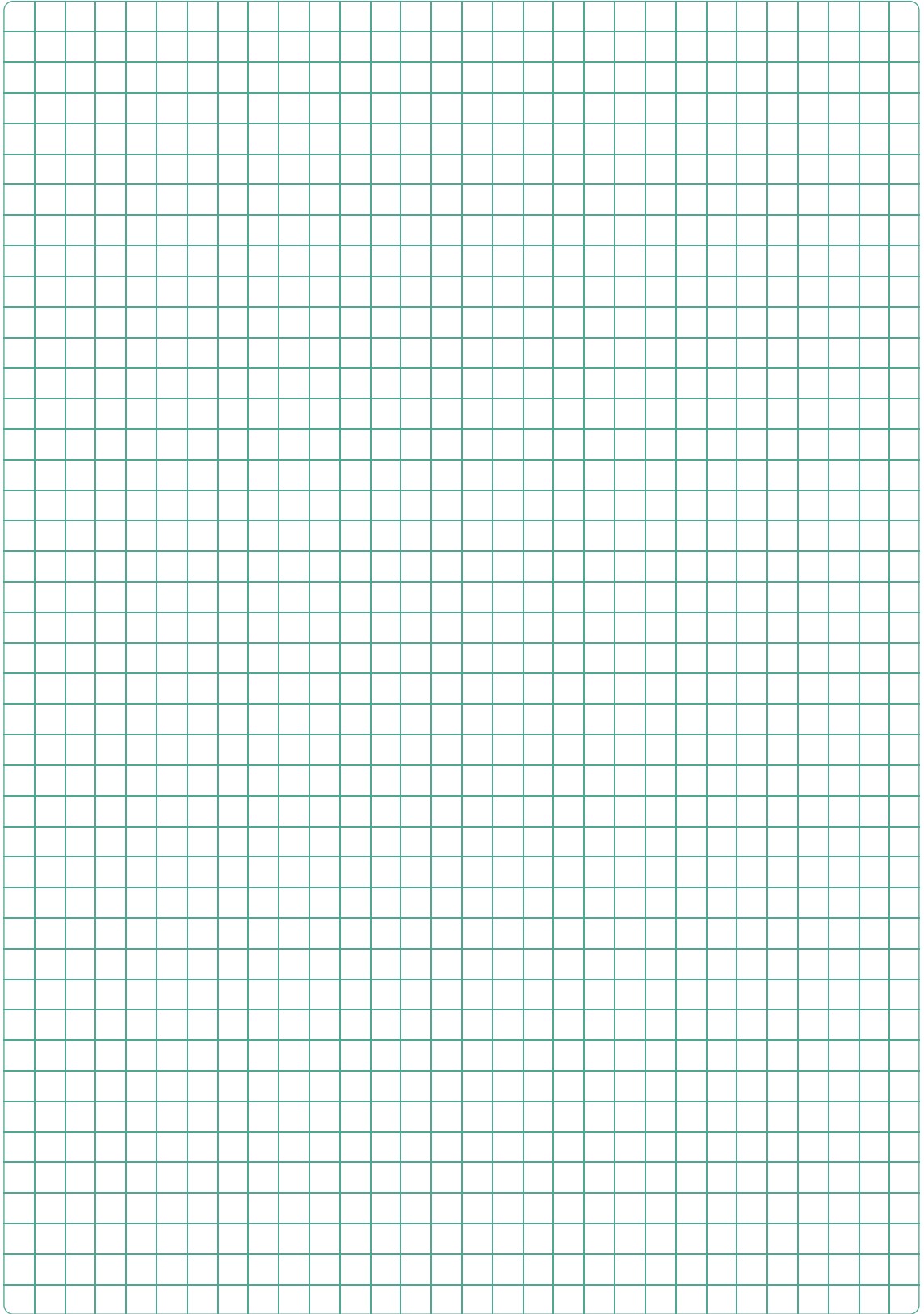

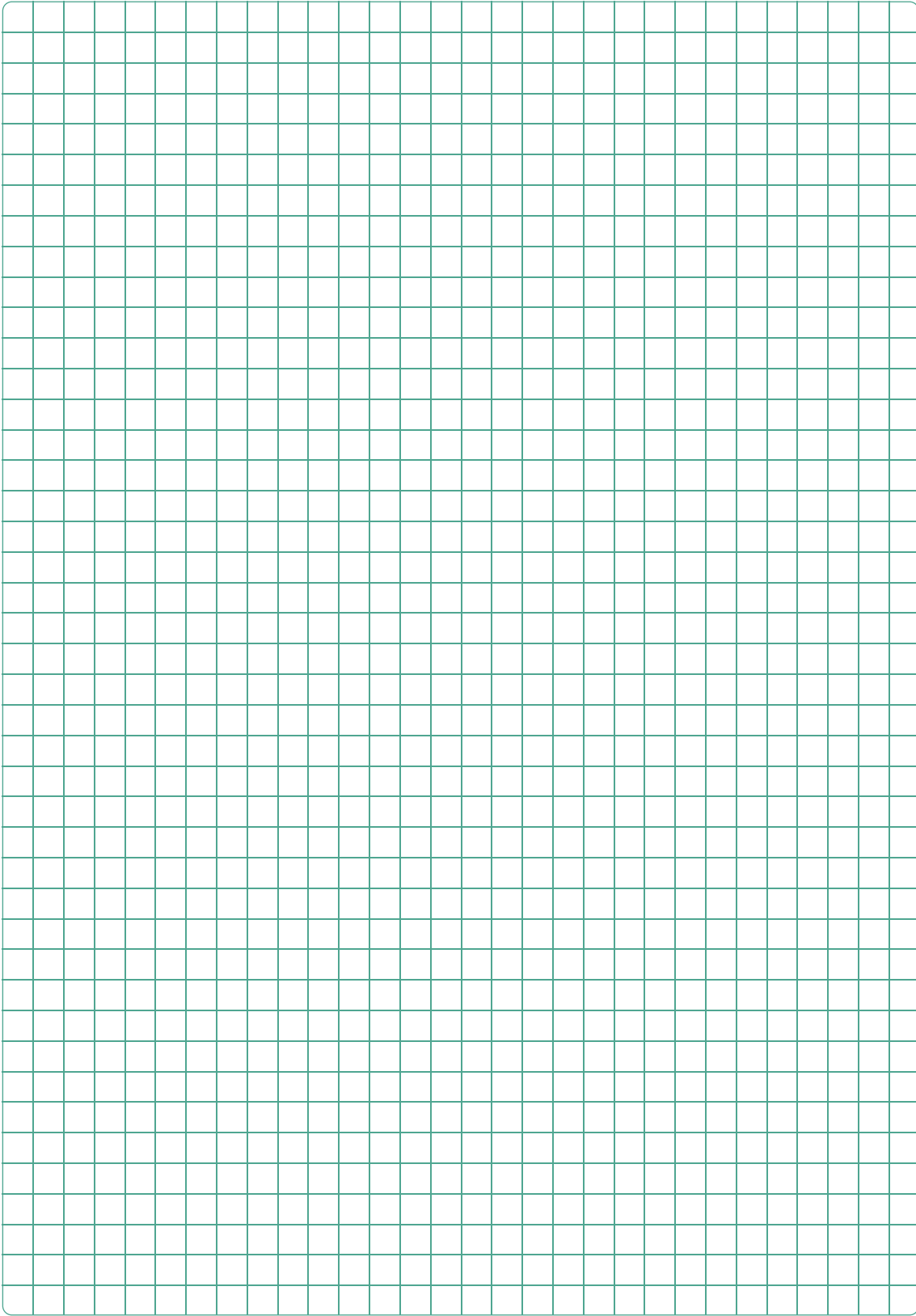

NOTES
NOTIZEN

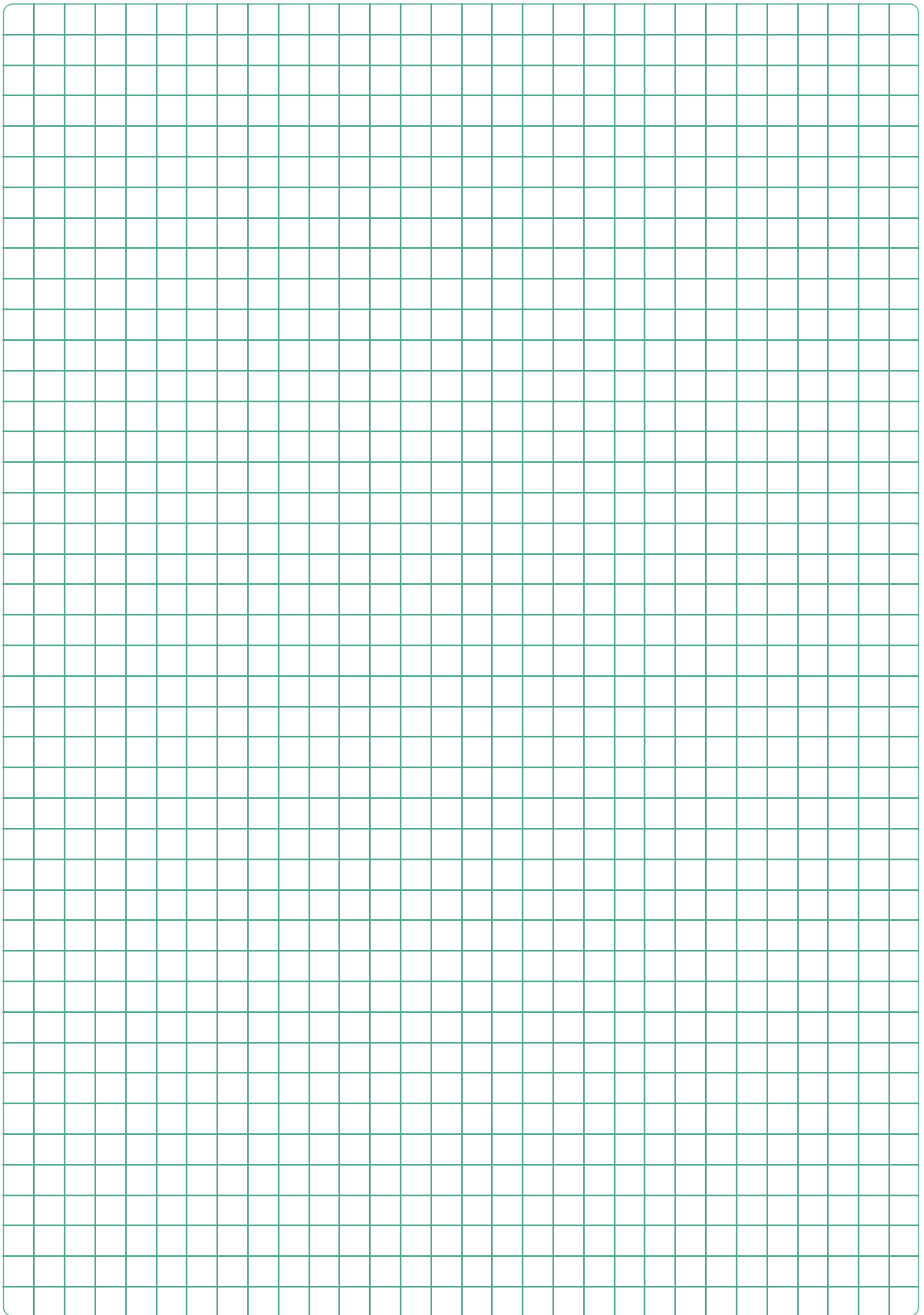

APPLICATION NOTES AND GENERAL INFORMATION



EXCELLENT EXPERIENCE IN CAPACITOR MAKING FOR OVER 80 YEARS

Gera has been a centre of capacitor making since 1938. ELECTRONICON Kondensatoren GmbH which emerged from previous RFT/VEB ELEKTRONIK Gera in 1992, has become one of Europe's leading capacitor manufacturers supplying customers worldwide and being an open and competent partner for manufacturers and users of power factor correction as well as industrial applications of power electronics, generation and transmission of green energy, traction, a.m.o. . Regular investments in advanced and environmentally sound technologies guarantee the highest levels in manufacture and quality to modern standards which are approved and monitored by leading certification authorities.



In today's globalised competition, we distinguish ourselves by

- Absolute reliability and safety of our products
- Close co-operation between manufacturer and client to meet both technical and commercial requirements
- Improvement and development of our technical expertise in capacitor design and manufacture, as well as film coating, with special attention paid to the MKPg-technology
- Early identification and incorporation of new trends and methods in the manufacturing of capacitors
- Flexibility and punctual fulfilment of our commercial obligations

Our experienced development engineers are competent and responsible for both implementing the latest technical trends applicable to our products and ensuring that our products adapt to the challenges of traditional and new markets. The close and intense co-operation between the departments of Marketing & Sales, Research & Development, and Production has become the keystone of our success. ELECTRONICON constantly strives for similarly close and interactive relationships with her sales partners and direct customers at home and abroad, so that we are not just one of many suppliers, but your preferred partner for ideas and solutions.

ELECTRONICON®

Germany • 07549 Gera • Keplerstrasse 2
Fon +49 365 / 734 61 00 • Fax +49 365 / 734 61 10
E-Mail: sales@electronicon.com, www.electronicon.com

